

contacto@potabilizar.solutions  
+54 (341) 627 7915  
González del Solar 101 Bis - Rosario, Santa Fe. Argentina.

## ***Model CYK Compound Centrifugal Liquid Units Style G***

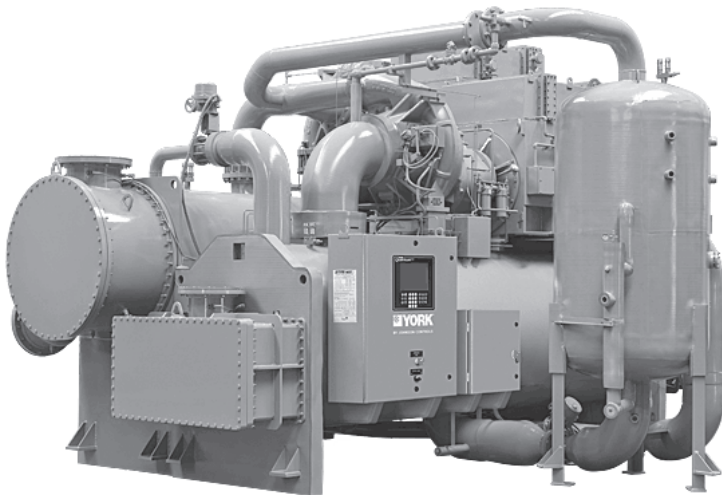

 **YORK**<sup>®</sup>

BY JOHNSON CONTROLS

**Cooling Duty:**  
300 through 2,500 Tons (1,050 through 8,800 kW)  
**Heating Duty:**  
10,000 through 40,000 MBH (2,900 through 11,700 kW)  
Air-cooled Radiators, Brine-chilling and Heat Pump Applications  
50 and 60 Hz  
Utilizing R-134a



# Table of Contents

**FORM 160.82-EG1 (712)** ..... 1

**Introduction**..... 3

**Sustainability Focus**..... 5

**Equipment Overview**..... 7

**Unit Components**..... 10

**Quantum LX Control Center**..... 11

**Accessories and Modifications**..... 14

**Application Data**..... 18

**Overall Unit Arrangement**..... 27

**Compact Nozzle Arrangements**..... 28

**Marine Nozzle Arrangements**..... 34

**Guide Specifications**..... 38

**SI Metric Conversion**..... 44

## NOMENCLATURE

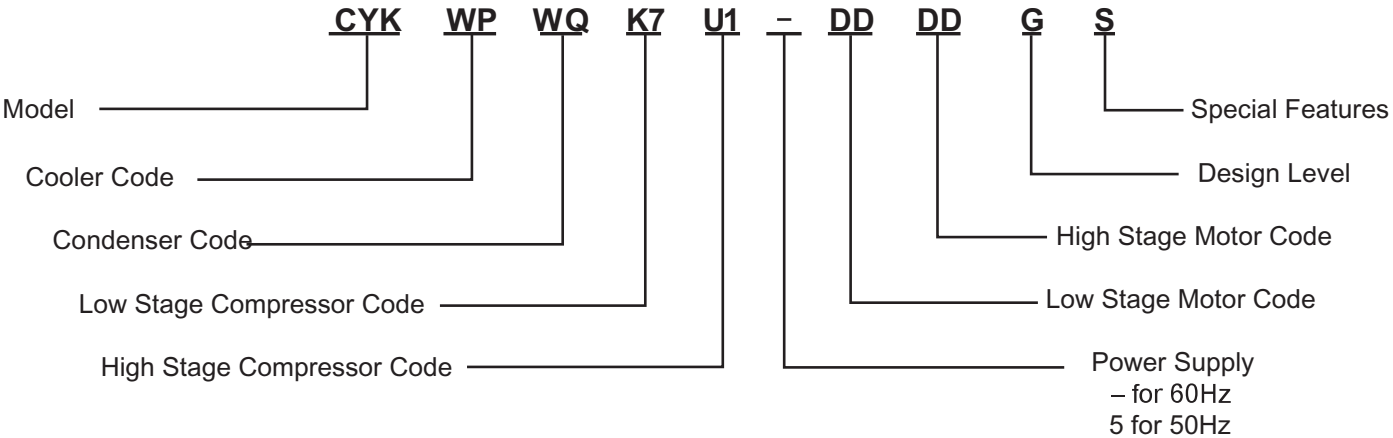

# Introduction

The YORK® Compound YK Unit (CYK) is a design using two centrifugal compressors arranged in series to handle radiator-cooled, brine-chilling, and heat-pump applications at conditions outside the range of typical centrifugal units. These custom units use R-134a refrigerant and are available in a wide range of capacities:

- For air-cooled applications, (air-cooled radiators) 600 to 2,500 tons up to 155°F LCWT (2,100 to 8,800 kW up to 68°C LCWT).
- For brine chilling, 300 to 2,000 tons (1,050 to 7,000 kW). Brine temperatures as low as 0°F (-18°C)
- For heat pump applications, 10,000 to 40,000 MBH (2,900 to 11,700 kW) heat rejection with LCWT up to 170°F (77°C).

## STANDARD COMPONENTS

Each compound unit employs common parts instead of a one-of-a-kind design. The compressors and heat exchangers use Johnson Controls' standard technology proven in the successful YORK product line. Each compressor is driven by a standard, open-drive electric motor.

## COMPACT FOOTPRINT

Compressors and motors are mounted above the shells to assure the smallest possible footprint for this type of unit.

## GREATER ADAPTABILITY

With a compound unit, impeller diameter, width and speed can be optimized for each stage of compression, based on operating conditions.

## SUPERIOR PART-LOAD PERFORMANCE

The CYK unit uses prerotation vane (PRV) capacity control for both compressors. Prerotation vanes act like a throttle on the suction side of the compressor to control compressor load. With PRV control on both compressors, the result is better part-load performance than for typical multistage compressors.

## HANDLES VARYING CONDENSING CONDITIONS

Since chillers most often operate at off-design conditions, off-design performance is a major factor in the energy savings equation. A compound chiller can operate with a wider range of condensing water temperatures than typical chillers. The compound chiller allows one compressor to be shut off, so the chiller can run on just one compressor during low head conditions. This practice not only ensures system stability, it allows the chiller to run more efficiently and takes advantage of lower cooling water temperatures.

## LOWER INRUSH CURRENT

Instead of starting a single, large motor, the CYK starts the two smaller motors in a staggered sequence. Consequently, peak inrush current is reduced to about 58% compared to starting a motor for a single large compressor.

## LOWER SOUND LEVELS

Acoustically, with compound compressors sharing the workload, compressor RPMs are lower than in standard centrifugal designs — and lower RPMs help lower sound levels.

## GRAPHIC CONTROL

A powerful, QuantumLX graphic control panel makes unit operation easy. The core of this panel is Linux, a robust and time-tested operating system. Startup is handled by a push of a button; there is no need for manual intervention in the start sequence of the compressors. A color multifunction touchscreen display (MFD) means operating parameters, set-points and alarms are easily accessible and clearly visible, ensuring proper reading and response.

## FLASH ECONOMIZER (INTERCOOLER)

The CYK Unit has a flash economizer (intercooler), resulting in increased efficiency during two stage operation.

## AIR-COOLED MOTORS

Hermetic-motor burnout can cause catastrophic damage to a unit. The entire unit must be cleaned, and the refrigerant replaced. YORK CYK centrifugal units with air-cooled motors eliminate this risk. Refrigerant never comes in contact with the motor, preventing contamination of the rest of the unit. Insurance companies that offer policies on large air conditioning equipment often consider air-cooled motors a significant advantage over hermetic refrigerant-cooled units.

## HIGH-EFFICIENCY HEAT EXCHANGERS

The unit heat exchangers offer the latest technology in heat transfer surface design to give you maximum efficiency and compact design. Water-side and refrigerant-side design enhancements minimize both energy consumption and tube fouling.

## SINGLE-STAGE COMPRESSOR DESIGN AND EFFICIENCY PROVEN IN THE MOST DEMANDING APPLICATIONS

Designed to be the most reliable units we've ever made, YORK CYK centrifugal units incorporate a single-stage compressor design. With fewer moving parts and straightforward, efficient engineering, YORK single-stage compressors have proven durability records in hospitals, chemical plants, gas processing plants, the U.S. Navy, and in other applications where minimal downtime is a crucial concern.

In thousands of installations worldwide, YORK single stage compressors are working to reduce energy costs. High strength aluminum-alloy compressor impellers feature backward-curved vanes for high efficiency. Airfoil shaped pre-rotation vanes minimize flow disruption for the most efficient part load performance. Precisely positioned and tightly fitted, they allow the compressor to unload

# Introduction

smoothly from 100% to minimum load for excellent operation in all applications.

## PRECISION CONTROL OF COMPRESSOR OIL PRESSURE

Using our expertise in variable-speed drive technology and applications, Johnson Controls has moved beyond the fixed head and bypass approach of oil pressure control. The old approach only assures oil pressure at the outlet of the pump rather than at the compressor, and allows no adjustment during unit operation. The CYK units feature two variable-speed drive oil pumps, monitoring and providing the right amount of oil flow to each compressor on a continuous basis. Variable-speed drive technology reduces oil pump power consumption, running only at the speed required, rather than at full head with a pressure regulating bypass valve. This design also provides sophisticated electronic monitoring and protection of the oil pump electrical supply, ensuring long life and reliable operation of the oil pump motors.

## FACTORY PACKAGING REDUCES FIELD LABOR COSTS

CYK centrifugal units are designed to keep installation costs low. Where installation access is not a problem, the unit can be shipped completely or partially packaged, requiring minimal piping and wiring to complete the installation.

The flash economizer (intercooler) ships separately for assembly with the unit at the time of installation. All piping between the economizer and the unit is prefabricated so no welding is required for installation.

## TAKE ADVANTAGE OF COLDER COOLING TOWER WATER TEMPERATURES

YORK CYK centrifugal chillers have been designed to take full advantage of colder cooling tower water temperatures, which are naturally available during most operating hours. Considerable energy savings are available by letting tower water temperature drop, rather than artificially holding it above 75°F (23.9°C), especially at low load, as some units require.

## COMPUTERIZED PERFORMANCE RATINGS

Each unit is custom-matched to meet the individual building load and energy requirements. Standard heat exchanger tube bundle sizes and pass arrangements,

are available to provide the best possible match. It is not practical to provide tabulated performance for each combination, as the energy requirements at both full and part load vary significantly with each heat exchanger and pass arrangement. Computerized ratings are available through each Johnson Controls sales office. These ratings can be tailored to specific job requirements.

## HIGH HEAD APPLICATIONS

- **Radiator Cooled:** The CYK can be used with air-cooled radiators in a closed loop, designed for areas where cooling towers are not allowed or water is scarce and expensive. The CYK has a huge advantage over low-cost and low-efficiency air-cooled units, due to high individual compressor capacity and high performance.
- **Thermal Storage:** The CYK can be used to produce ice during the night and chilled solution during the day. This unit is well suited in regions with expensive energy cost (demand and usage). The CYK has a huge advantage over 2-stage commercial units or low temperature screw units, based upon the excellent efficiency at both duties.
- **Turbine Inlet Air Cooling:** A CYK can be used to combine both previous applications to improve the performance of gas turbine in regions with a very hot climate and a scarcity of water. The CYK can provide a better initial cost and higher capacities than custom-built low temperature screw packages.
- **Low Temperature Process Cooling:** The CYK can be applied in industrial applications to produce chilled solution with strict requirements, like Class 1, Group D, Div 2. When used in this application, the CYK has advantages versus custom-built screw packages, based on the excellent efficiency, higher individual capacity and lower initial cost.
- **Heat Pump:** The CYK is ideal for use in heat pump applications, supplying up 170°F (77°C) leaving condenser water. In this application, the CYK can provide coefficients of performance over 4 times greater than water heaters. More information on heat pump applications can be found in Johnson Controls Form PUBL-6142.

# Sustainability Focus

## OZONE-DEPLETION POTENTIAL (ODP)

The YORK CYK unit employs one the most environmentally friendly refrigerants available today, HFC-134a, with no Ozone Depletion Potential (ODP) and no phase out date per the Montreal Protocol.

Ozone is a very small part of the atmosphere, but its presence is nevertheless vital to human well-being. Most ozone resides in the upper part of the atmosphere. This region, called the stratosphere, is more than 10 kilometers (6 miles) above the Earth's surface. There, about 90% of atmospheric ozone is contained in the "ozone layer," which shields us from harmful ultraviolet radiation from the sun. However, it was discovered in the mid-1970s that some human-produced chemicals could destroy ozone and deplete the ozone layer. The resulting increase in ultraviolet radiation at the Earth's surface may increase the incidences of skin cancer and eye cataracts. Following the discovery of this environmental issue, researchers focused on gaining a better understanding of this threat to the ozone layer.

Monitoring stations showed that ozone-depleting chemicals were steadily increasing in the atmosphere. These trends were linked to growing production and use of chemicals like chlorofluorocarbons (CFCs) for refrigeration and air conditioning, foam blowing, and industrial cleaning. Measurements in the laboratory and the atmosphere characterized the chemical reactions that were involved in ozone destruction. Computer models employing this information could predict how much ozone depletion was occurring and how much more could occur in the future.

Observations of the ozone layer showed that depletion was indeed occurring. The most severe and most surprising ozone loss was discovered to be recurring in springtime over Antarctica. The loss in this region is commonly called the "ozone hole" because the ozone depletion is so large and localized. A thinning of the ozone layer also has been observed over other regions of the globe, such as the Arctic and northern middle latitudes. The work of many scientists throughout the world has provided a basis for building a broad and solid scientific understanding of the ozone depletion process. With this understanding, we know that ozone depletion is occurring and why. And, most important, we know that if ozone-depleting gases were to continue to accumulate in the atmosphere, the result would be more depletion of the ozone layer. In response to the prospect of increasing ozone depletion, the governments of the world crafted the 1987 United Nations Montreal Protocol as a global means to address this global issue. As a result of the broad compliance with the Protocol and its Amendments and Adjustments and, of great significance, industry's development of "ozone friendly" substitutes for the now-controlled chemicals, the total global accumulation of ozone-depleting gases has slowed and begun to decrease. This has reduced the risk of further ozone depletion.

## THE MONTREAL PROTOCOL ADDRESSED CFC'S AND HCFC'S

The Montreal Protocol (MP) addressed CFC's and HCFC's with phase out schedule for all member parties of the MP based on the ODP characteristics. So this affects the first

	REFRIGERANT	COMMON USE	ODP	GWP	STATUS	2007 GLOBAL USAGE (TONS)
CFC	CFC-11	CENTRIFUGALS	1.00	5000	PHASED OUT	TRACE
	CFC-12	CENTRIFUGALS	0.80	8500	PHASED OUT	TRACE
HCFC	HCFC-22	SCROLLS, SCREWS, UNITARY PRODUCTS	0.05	1700	PHASING OUT	700,000
	HCFC-123	CENTRIFUGALS	0.02	120	PHASING OUT	4,000
HFC	HFC-134A	CENTRIFUGALS, SCREWS	-	1300	NO PHASE OUT	250,000
	HFC-407C	SCREWS, SCROLLS	-	1600	NO PHASE OUT	100,000
	HFC-410A	SCROLLS, UNITARY PRODUCTS	-	1890	NO PHASE OUT	
	HFC-404A		-	3750	NO PHASE OUT	
	HFC-245FA	CENTRIFUGALS	-	1020	NO PHASE OUT	TRACE
	HFO-1234YF	CENTRIFUGALS	-	4	NO PHASE OUT	
HC (NATURAL REFR.)	HC-717 (NH <sub>3</sub> )	SCREWS, CENTRIFUGALS	-	1	NO PHASE OUT	
	HC-718 (WATER)	ABSORPTION, VAPOR COMPRESSION	-	0	NO PHASE OUT	
	HC-290 (PROPANE)		-	3	NO PHASE OUT	
	HC-600A (BUTANE)		-	3	NO PHASE OUT	
	HC-744 (CO <sub>2</sub> )		-	1	NO PHASE OUT	

# Sustainability Focus

two categories of refrigerants listed in the table. Manufacturers in developed nations are in the final processes of converting from HCFC's to HFC's in accordance with the Montreal Protocol treaty. Markets in developing countries are already seeing a transition away from HCFC's ahead of legislative requirements.

HCFC's were used as a transitional refrigerant as they were a "Lesser Evil" and allowed the HVAC industry to quickly transition away from CFCs while maintaining energy efficiency. The fact remains that they destroy the ozone layer and are legislated to be completely phased out.

The Montreal Protocol does not extend to HFC's as they have no ODP nor does it extend to natural refrigerants for the same reason.

The typical usage of the refrigerant, the phase-out status by the Montreal Protocol and the global usage of refrigerant in tons is shown in the table on pg 5.

The chart below shows the growing use of HFC-134a in centrifugal units from 1995 up to 2010 and the forecast until the phase-out of HCFC's.

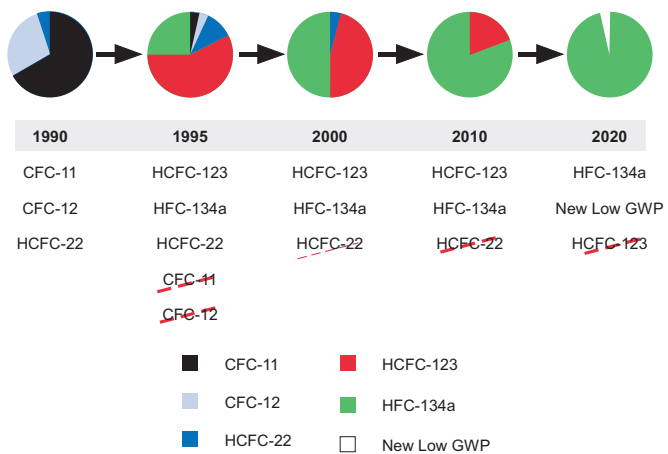

## GLOBAL WARMING POTENTIAL (GWP)

Another main environmental topic is Global Warming potential (GWP), and when we talk about global warming we're primarily talking about smoke stacks and tail pipes. 85% of GWP is attributed to CO<sub>2</sub> emissions, while only about 2% is related to HFC's.

However, when we talk about the direct impact our YORK CYK Centrifugal Unit has on the environment we can make strides forward, like ensuring leak tight designs are created, and manufacturers are working to reduce refrigerant charges as much as possible.

## DIRECT & INDIRECT GLOBAL WARMING POTENTIAL

98% of the global warming potential of a centrifugal unit is from the indirect effect or the greenhouse gases produced

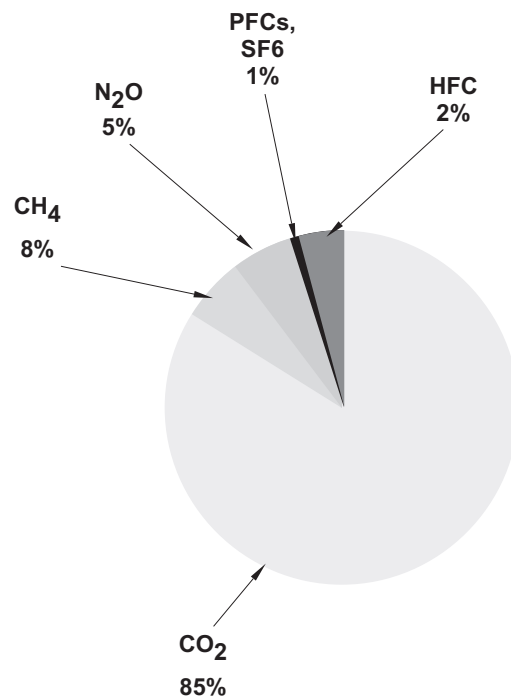

to generate the electricity to run the unit. The YORK CYK centrifugal unit and its superior efficiency levels dramatically reduces the indirect GWP. 2% of the GWP is from the direct effect or release of the refrigerant gases into the atmosphere.

Minimizing the total climatic impact (direct and indirect GWP) requires a comprehensive approach to refrigerant choice.

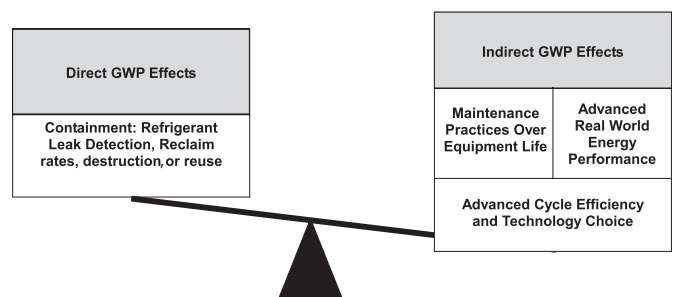

# Equipment Overview

## GENERAL

YORK CYK Compound Centrifugal Liquid Units are factory-packaged including the evaporator, condenser, compressor, motor, lubrication system, control center, and interconnecting unit piping and wiring. The flash economizer (intercooler) ships loose for assembly with the unit at time of installation. All piping between the economizer and the units is prefabricated in the factory. No welding is required in the field.

The initial charge of refrigerant and oil is supplied for each unit. Actual shipping procedures will depend on a number of project-specific details.

## COMPRESSOR

Each compressor is a single-stage centrifugal type powered by an air-cooled electric motor. The casing is fully accessible with vertical circular joints and fabricated of close-grain cast iron. The complete operating assembly is removable from the compressor and scroll housing.

The rotor assembly consists of a heat-treated alloy steel drive shaft and impeller shaft with a high strength, cast aluminum alloy, fully shrouded impeller. The impeller is designed for balanced thrust and is dynamically balanced and overspeed tested for smooth, vibration free operation.

The insert-type journal and thrust bearings are fabricated of aluminum alloy and are precision bored and axially grooved. The specially engineered, single helical gears with crowned teeth are designed so that more than one tooth is in contact at all times to provide even distribution of compressor loads and quiet operation. Gears are integrally assembled in the compressor rotor support and are film lubricated. Each gear is individually mounted in its own journal and thrust bearings to isolate it from impeller and motor forces.

## FLASH ECONOMIZER (INTERCOOLER)

The flash economizer (intercooler) is a single-stage design. It consists of a vertical pressure vessel with internally mounted mesh eliminators and a liquid spray pipe, an externally mounted (field installed) level transmitter located with a liquid level pipe assembly, and an external control valve mounted in the liquid outlet to the evaporator. Refrigerant from the condenser, after expanding through the condenser subcooler level control valve, enters through the internal spray pipe, where flash gas is removed and channeled through the mesh eliminator, out the top and into the high stage compressor section. The remaining liquid feeds out of the economizer through a liquid level control valve into the evaporator. Eight sight glasses are provided: two above and two below the mesh eliminators; two at the liquid spray pipe; and two in the liquid line leav-

ing the economizer. A thermometer well is furnished for checking the liquid temperature. Connections are provided for the Johnson Controls furnished, field installed pressure transmitter and relief valve assemblies. Three support legs of structural steel are provided with mounting brackets for spring type isolators. Refrigerant connections are as follows: high pressure liquid inlet, interstage flash gas top outlet, and low pressure liquid bottom outlet.

## CAPACITY CONTROL

Pre-rotation vanes (PRV) in each compressor modulate unit capacity from 100% to 15% of design for normal air conditioning applications. Operation is by an external, electric PRV actuator which automatically controls the vane position to maintain a constant leaving chilled liquid temperature (or leaving condenser temperature for a heat pump application). Rugged airfoil shaped cast manganese bronze vanes are precisely positioned by solid vane linkages connected to the electric actuator.

Both compressors are normally operated to satisfy the evaporator load (or the condenser load in the case of a heat pump). Should the entering condensing water temperature drop below a preset temperature, a compressor will be taken off line. This allows the remaining compressor to continue operating more efficiently at low entering condensing water temperatures.

## OPTISOUND™ CONTROL

The YORK OptiSound Control is a patented combination of centrifugal unit hardware and software that reduces operational sound levels, expands the unit operating range, and improves unit performance. The OptiSound Control feature continuously monitors the characteristics of the compressor-discharge gas and optimizes the diffuser spacing to minimize gas-flow disruptions from the impeller. This innovative technology improves operating sound levels of the unit an average of 7 dBA, and up to 13 dBA on the largest models. It can also reduce part-load sound levels below the full-load level.

In addition, the OptiSound Control provides the benefit of an expanded operating range. It improves performance and reliability by minimizing diffuser gas stall at off-design operation, particularly conditions of very low load combined with little or no condenser-water relief. The elimination of the gas-stall condition can also result in improved unit efficiency at off design conditions.

Johnson Controls includes the OptiSound Control for all CYK units when it is available on the compressors used. It is not available on all compressors.

# Equipment Overview

## LUBRICATION SYSTEM

Lubrication oil is force-fed to all bearings, gears and rotating surfaces by a variable speed drive pump; which operates prior to startup, and continuously during operation and during coast-down. A gravity-fed oil reservoir is built into the top of each compressor to provide lubrication during coast-down in the event of a power failure.

Dual oil reservoirs, separate from the compressors, contain the 2 HP submersible oil pumps and 1500 watt immersion-type oil heaters for each compressor. The oil heaters are thermostatically controlled to remove refrigerant from the oil.

A water-cooled oil cooler is provided after each oil pump, with factory installed water piping terminating at the center on the condenser side of the unit. A thermostatically controlled bypass valve maintains the required oil temperature supply from each oil cooler to its compressor. Oil is filtered by externally mounted, 1/2 micron, replaceable cartridge oil filters, equipped with service valves. An automatic oil return system recovers any oil that may have migrated to the evaporator. Oil piping is completely factory installed.

## MOTOR DRIVELINE

The compressor motors are open drip-proof, squirrel cage, induction type constructed to YORK design specifications. 60 hertz motors operate at 3570 rpm. 50 hertz motors operate at 2975 rpm.

The open motor is provided with a D-flange, and is factory-mounted to a cast iron adapter mounted on the compressor. This unique design allows the motor to be rigidly coupled to the compressor to provide factory alignment of motor and compressor shafts.

Motor drive shaft is directly connected to the compressor shaft with a flexible disc coupling. Coupling has all metal construction with no wearing parts to assure long life, and no lubrication requirements to provide low maintenance.

A large, steel terminal box with gasketed front access cover is provided on each motor for field-connected conduit. There are six terminals (three for medium voltage) brought through the motor casing into the terminal box. Jumpers are furnished for three-lead types of starting. Motor terminal lugs are not furnished.

## HEAT EXCHANGERS

### Shells

Evaporator and condenser shells are fabricated from rolled carbon steel plates with fusion welded seams. Carbon steel tube sheets, drilled and reamed to accommodate the tubes, are welded to the end of each shell. Intermediate tube supports are fabricated from carbon steel plates, drilled and reamed to eliminate sharp edges, and spaced no more than four feet apart. The refrigerant side of each shell is designed, tested, and stamped in accordance with ASME Boiler and Pressure Vessel Code, Section VIII – Division I.

### Tubes

Heat exchanger tubes are state-of-the-art, high-efficiency, externally and internally enhanced type to provide optimum performance. Tubes in both the evaporator and condenser are 3/4" or 1" O.D. copper alloy and utilize the "skip-fin" design, providing a smooth internal and external surface at each intermediate tube support. This provides extra wall thickness (up to twice as thick) and non-work hardened copper at the support location, extending the life of the heat exchangers. Each tube is roller expanded into the tube sheets providing a leak-proof seal, and is individually replaceable.

### Evaporator

The evaporator is a shell and tube, flooded type heat exchanger. A distributor trough provides uniform distribution of refrigerant over the entire shell length to yield optimum heat transfer. Mesh eliminators or baffles are located above the tube bundle to prevent liquid refrigerant carryover into the compressor. A 1.5" (38mm) liquid level sight glass is conveniently located on the side of the shell to aid in determining proper refrigerant charge. The evaporator shell contains a dual refrigerant relief valve arrangement set to pressures up to 235 psig (16.2 barg). A 1" refrigerant charging valve is provided.

### Condenser

The condenser is a shell and tube type, with discharge gas baffles to prevent direct high velocity impingement on the tubes. The baffles are also used to distribute the refrigerant gas flow properly for most efficient heat transfer. An integral sub-cooler is located at the bottom of the condenser shell providing highly effective liquid refrigerant sub-cooling to provide the highest cycle efficiency. The condenser contains dual refrigerant relief valves that can be set to pressures up to 350 psig (24.1 barg).



## WATER BOXES

The removable water boxes are fabricated of steel. The design working pressure is 150 psig (10.3 barg) and the boxes are tested at 225 psig (15.5 barg). Integral steel water baffles are located and welded within the water box to provide the required pass arrangements. Stub-out water nozzle connections with ANSI/AWWA C-606 grooves are welded to the water boxes. These nozzle connections are suitable for ANSI/AWWA C-606 couplings, welding or flanges, and are capped for shipment. Plugged 3/4" drain and vent connections are provided in each water box.

## WATER FLOW SWITCHES

Thermal type water flow switches are factory mounted in the chilled and condenser water nozzles, and are factory wired to the control panel. These solid state flow sensors have a small internal heating element. They use the cooling effect of the flowing fluid to sense when an adequate flow rate has been established. The sealed sensor probe is 316 stainless steel, which is suited to very high working pressures.

## ZERO LOAD HOT GAS BYPASS

Sized for operation to 0% evaporator load to prevent nuisance shutdowns due to low load conditions, and critical industrial and process applications.

## LOW INLET CONDENSER WATER CAPABILITY

The CYK Compound unit incorporates a control strategy that allows a compressor to shut down automatically when two-compressor operation is no longer required. This allows the unit to take advantage of low-inlet condenser water temperatures to reduce energy consumption.

## CODES AND STANDARDS

- ASME Boiler and Pressure Vessel Code – Section VIII Division 1.
- AHRI Standard 550/590 (When applicable)
- ASHRAE 15 – Safety Code for Mechanical Refrigeration
- ASHRAE Guideline 3 – Reducing Emission of Halogenated Refrigerants in Refrigeration and Air-Conditioning Equipment and Systems
- N.E.C. – National Electrical Code
- OSHA – Occupational Safety and Health Act

## ISOLATION MOUNTING

The unit is provided with four vibration isolation mounts consisting of 1" (25.4 mm) thick neoprene isolation pads for field mounting under the steel mounting pads located on the tube sheets and three pads for the flash economizer (intercooler).

## REFRIGERANT CONTAINMENT

The standard unit has been designed as a complete and compact factory-packaged unit except for the flash economizer. The piping between the economizer and the main unit is all prefabricated in the factory with strategically placed flanges. No field welding is necessary to attach the economizer. As such, it has minimum joints from which refrigerant can leak. The entire assembly has been thoroughly leak tested at the factory prior to shipment. The CYK unit includes service valves, conveniently located to facilitate transfer of refrigerant to a remote refrigerant storage/recycling system.

## PAINT

Exterior surfaces are protected with one coat of Caribbean blue, durable alkyd-modified, vinyl enamel, machinery paint.

## SHIPMENT

Protective covering is furnished on the motor, control center, and unit-mounted controls. Water nozzles are capped with fitted plastic enclosures. Entire unit is protected with industrial-grade, reinforced shrink-wrapped covering. The flash economizer (intercooler) is removed for shipment. Flanged joints are provided and all piping is prefabricated.

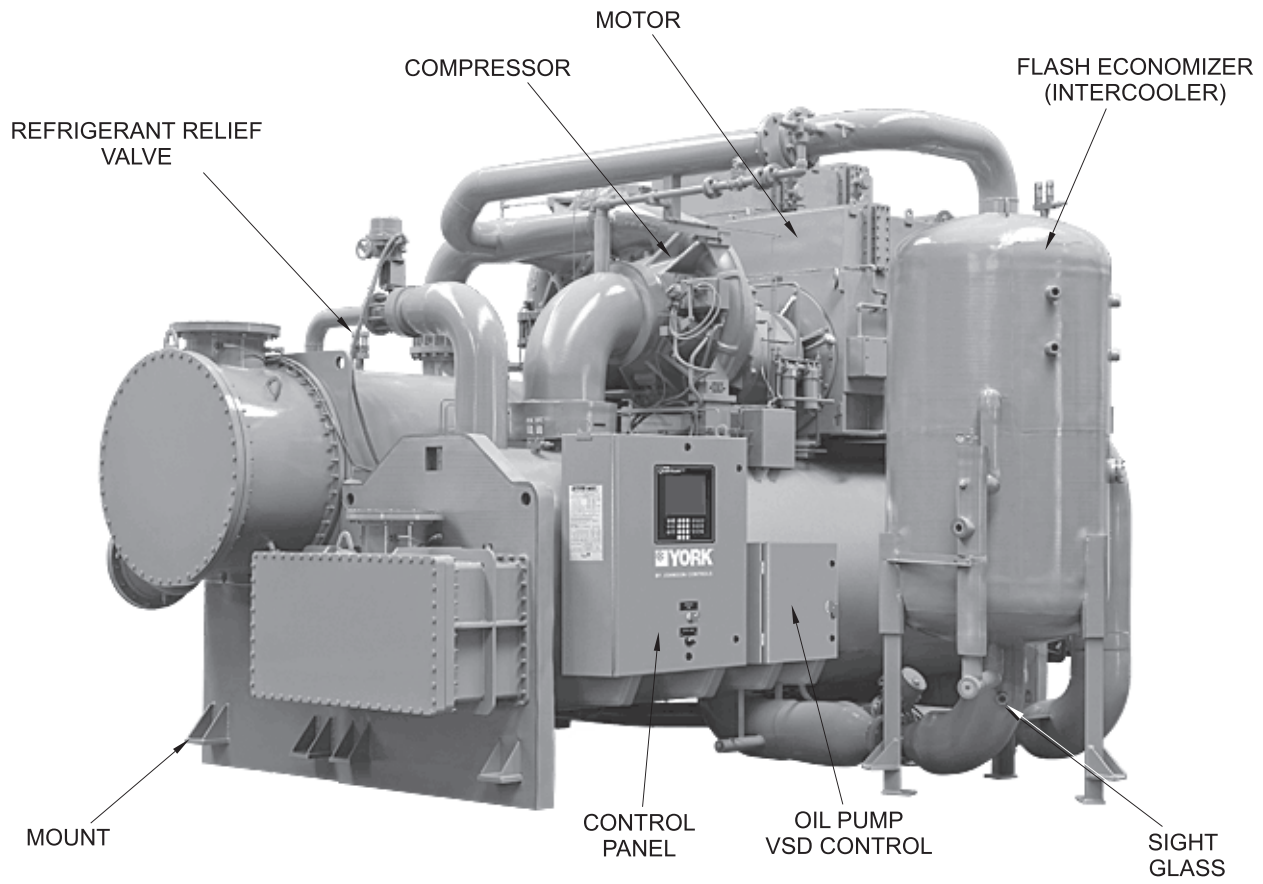

# Quantum LX Control Center



## QUANTUM LX CONTROL CENTER

The unit is controlled by a stand-alone QuantumLX microprocessor-based control center with a Linux-based operating system. The unit control center provides all the necessary controls and control logic to provide automatic start-up, automatic operation, capacity control and safety protection of the unit.

## CONTROL PANEL

The control panel includes a 10.4" color active matrix MFD with integral keypad for operator interface. The control panel is a factory wired, unit mounted, NEMA 12, gasketed enclosure. The panel is fabricated of 10 gauge steel and includes a full-height front access door. The panel enclosure is painted to match the unit color. All controls are arranged for easy access and internally wired to clearly marked terminal strips or pre-wired I/O Board pluggable terminations for wiring connections. Wiring is color-coded black for power, red control, light-blue (neutral), and green (ground), with each wire numerically identified at both ends with wire markers. Wiring enclosed in shielded cables and pre-wired cables are color coded per the wiring diagram.

The screen details all operations and parameters, using a graphical representation of the unit and its components. Graphic screens are provided for:

- a. Unit Overview
- b. Evaporator
- c. Condenser
- d. Low stage compressor
- e. High stage compressor
- f. Motors
- g. Capacity control diagram
- h. Manual/Auto stations for all control outputs

The MFD is programmed to display all major operating parameters in both graphical and list-type screen displays. PID control loop set points and Manual/Auto functions are also accessed by the MFD. Operator interaction is provided by a touch screen interface. Alarm indicators on the MFD provide annunciation, and an alarm history screen is provided which shows the most recent alarms, with the time and date of the occurrence. Trip status inputs at the time of the last 128 unit safety shutdowns. The time and date of the shutdown are also shown. Function keys are provided on the keypad for Unit Start, Stop, Reset, and Emergency Stop.

## CAPACITY CONTROLS SYSTEM

The capacity control philosophy of the YORK CYK unit control system allows efficient, fully automated control, without need for operator intervention. This control system also monitors and displays all safety aspects of the unit and provided alarms and a shutdown if safety limits are exceeded. If operator intervention is required, manual controls are provided on the MFD for all electric actuators.

The capacity controls algorithm automatically seeks out the most efficient operation of the CYK unit. The pre-rotation vanes are adjusted to maintain chilled water production. In cases of low load, the pre-rotation vanes automatically throttle and are limited to a minimum anti-surge position. To provide light-duty operation, the hot-gas recycle valve is seamlessly throttled open according to temperature demands. This keeps the centrifugal compressor out of surge and maintains chilled water production.

In cases of high load, which exceeds the motor kilowatt (or current) usage, the capacity-controls algorithm automatically unloads the system to maintain a restriction on power consumption. In the same way, conditions of high discharge pressure or low suction pressure override the

# Quantum LX Control Center

production of chilled water in the interests of keeping the unit online.

## HEAT PUMP

The Heat Pump is limited to produce heat on the available heat extracted from the chilled water loop. If there is insufficient load on the chilled water loop, then hot gas will generate as much heat as it can to make up the lack of source heat from the chilled loop. More importantly the Heat Pump must have sufficient load on the condenser (heating) side to carry away the heat of compression of the system. The Design working pressure of the condenser vessel is the limiting factor of the hot water production. On the condenser side of the heat pump, if the load is less than the heat of compression load plus the refrigeration effect, the system will not be able to stay online as the total heat generated in the heat pump is not removed from the heating water loop and will accumulate causing a high pressure shutdown.

Heat Pump mode and Unit/Heat Recovery capacity controls operation are mutually exclusive operational modes. The Unit mode produces cold water at setpoint, and any hot water recovered simply a benefit. The inverse is also true. Whichever limitation is reached first becomes the limiting factor and the Heat Pump will unload based on low water temperature or high discharge pressure. There are also limitations on the lift of the single stage centrifugal compressor if the chilled water loop gets too low, which will result in wide-open vane surge if exceeded.

### Analog Input List:

1. Low Stage Motor Current (% FLA)
2. High Stage Motor Current (% FLA)
3. Subcooler Refrigerant Liquid Level
4. Low Stage Oil Reservoir Oil Level (Brine Units)
5. High Stage Oil Reservoir Oil Level (Brine Units)
6. Evaporator Refrigerant Pressure
7. Condenser Refrigerant Pressure
8. Low Stage Compressor Low Oil Pressure
9. Low Stage Compressor High Oil Pressure
10. High Stage Compressor Low Oil Pressure
11. High Stage Compressor High Oil Pressure
12. Chilled Water-Out Temperature.
13. Chilled Water-In Temperature.
14. Condenser Water In Temperature
15. Condenser Water Out Temperature
16. Evaporator Refrigerant Liquid Temp.
17. Low Stage Compressor Refrigerant Discharge Temperature

18. High Stage Compressor Refrigerant Discharge Temperature
19. Subcooled Refrigerant Liquid Temperature
20. Low Stage Compressor Oil Temperature
21. High Stage Compressor Oil Temperature
22. Low Stage PRV Position
23. High Stage PRV Position
24. Low Stage Compressor high stage thrust Bearing Probe Gap
25. High Stage Compressor thrust bearing Probe gap
26. Flash Economizer Pressure
27. Flash Economizer Refrigerant Liquid Level

### Digital Inputs:

1. Chilled Water Low Flow Switch
2. Condenser Water Low Flow Switch
3. Low Stage Motor Starter Full Voltage (Run) Auxiliary Contact
4. High Stage Motor Starter Full Voltage (Run) Auxiliary Contact
5. Low Stage Motor Starter Safety Fault Lockout Relay
6. High Stage Motor Starter Safety Fault Lockout Relay
7. Condenser Refrigerant High Pressure Cutout
8. Low Stage Compressor Oil Heater Thermostat
9. High Stage Compressor Oil Heater Thermostat
10. Low Stage PRV Closed Limit Switch
11. High Stage PRV Closed Limit Switch
12. Low Stage Compressor V.S. Oil Pump Drive Faulted Contact
13. High Stage Compressor V.S. Oil Pump Drive Faulted Contact
14. Optional Remote Unit Start Input
15. Emergency Stop

### Analog Output List

1. Hot Gas Bypass Valve
2. Low Stage Compressor, V.S. Oil Pump Drive Control
3. High Stage Compressor, V.S. Oil Pump Drive Control
4. High Pressure Variable Orifice Valve LCV-114
5. Low Pressure Variable Orifice Valve LCV-116
6. Bypass Level Control valve output LCV-117

## Digital Output List

1. Low Stage Liquid Line Solenoid Valve
2. High Stage Liquid Line Solenoid Valve
3. High Stage Oil Return Solenoid (brine units only)
4. Low Stage Oil Return Solenoid Valve
5. Low Stage Compressor Oil Heater Contactor
6. High Stage Compressor Oil Heater Contactor
7. Low Stage Compressor Motor Start/Stop Control Relay
8. High Stage Compressor Motor Start/Stop Control Relay
9. Low Stage Compressor Oil Pump Start/Stop Relay
10. High Stage Compressor Oil Pump Start/Stop Relay
11. Oil Level Control Pump Start/Stop Relay (brine units only)
12. Open Low Stage PRV
13. Open High Stage PRV
14. Close Low Stage PRV
15. Close High Stage PRV
16. Interstage Sideload Valve

## Optisound Control Outputs (when available)

1. Open Low Stage VGD
2. Close Low Stage VGD
3. Open High Stage VGD
4. Close High Stage VGD

## Security

Security access to prevent unauthorized change of set-points, to allow local or remote control of the unit, and to allow manual operation of the pre-rotation vanes and oil pump. Access is through ID and password recognition, which is defined by three different levels of user competence: operator, service and factory.

## Over-Current Protection

A fused connection through a transformer on the Variable Speed Oil Pump Panel to provide individual over-current protected power for all controls.

## PLANT MANAGEMENT/CONTROL SYSTEM INTERFACE:

Ethernet is the preferred LAN (Local Area Network) between Local Unit Control Panels. Ethernet allows full

management of the QuantumLX system from a central location.

The QuantumLX control system can be accessed remotely by any internet browser, when it is incorporated into an ethernet network. This virtual operator interface allows quick access to the units for full remote management without having to create a separate SCADA or supervisory control.

All required analog and discrete data for communications will be arranged in blocks of 16-bit words. All data is available remotely as read only values. The following write-able control signals are available. Remote Start, Remote Stop, Remote Leaving Chilled Water Setpoint, and Remote Demand Limit Setpoint.

## Available Network Protocols

Any protocol/media requirements not listed in Table 1 must be called out on the factory order form.

**TABLE 1 - AVAILABLE NETWORK PROTOCOLS**

MEDIA	PROTOCOL
CAT-5 TWISTED PAIR	ETHERNET INDUSTRIAL PROTOCOL AND MODBUS TCP <a href="http://WWW.ETHERNET-IP.ORG">WWW.ETHERNET-IP.ORG</a>
RS-232	ALLEN-BRADLEY DF1 FULL DUPLEX
RS-232	MODBUS RTU SLAVE/ASCII SLAVE

Available protocols will be implemented with a Johnson Controls **eLink** module\* or **RedLion Data Station** where applicable:

- Modbus RTU over RS-485\*\*
- BACnet MS/TP\*
- BACnet/IP\*
- Profibus\*\*
- Allen-Bradley DH-485

**Check appropriate protocol and include this document attached to the Factory Order Form.**

All communication interface wiring and hardware, which is required external to the unit control panel, will be supplied and installed by the electrical installation contractor under another contract.

# Accessories and Modifications

## STARTERS

Solid state starters are available from Johnson Controls as floor mounted assemblies for medium voltage applications. Electromechanical starters are available, selected for proper size and type for job requirements and in accordance with Johnson Controls Engineering Standard (R-1177) for Starters. The starter assemblies have contactors and accessories for controlling the two compressor motors per unit.

### REMOTE MOUNTED MEDIUM VOLTAGE SOLID-STATE STARTER

The Medium Voltage Solid-State Starter is a reduced voltage in-line bypass starter that controls and maintains a constant current flow to the motor during startup. Power and control wiring between the starter and the unit for the unit mounted version is factory-installed. Available for 2300 - 4160 volts (Table 2), the starter enclosure is NEMA-1, with a hinged access door with lock and key. Electrical lugs for incoming power wiring are not provided.

Standard Features include digital readout at the Control Center of the following:

#### Display Only

- 3-phase input voltage
- 3-phase current
- Input Power (kW)
- Killowatt-Hours (KWH)
- Starter Model
- Motor Run (LED)
- Motor Current % Full Load Amps
- Current Limit Setpoints
- Pulldown Demand Time Left

#### Programmable

- Local Motor Current Limit
- Pulldown Demand Limit
- Pulldown Demand Time

Other features include: low line voltage; 115V control transformer; three-leg motor current sensing overloads; phase rotation and single-phase failure protection; high temperature safety protection; motor current imbalance and under-voltage safeties; open and shorted SCR protection; momentary power interruption protection. The Solid-State Starter is air cooled generating about the same heat as an auto-transformer E-M starter. Ground fault protection and surge protection are also standard features. The 50,000 amp short circuit withstand rating is in accordance with UL Standard 508. See Table 2 for availability and additional advantages of Solid-State Starters.

### ELECTROMECHANICAL STARTER - (FIELD INSTALLED)

#### A. Characteristics

For comparison purposes, here is a description of some of the general characteristics of electromechanical starters. Until the development of the Solid-State Starter, all centrifugal units required the use of starters using electromechanical contactors, which are limited to operating totally ON, or totally OFF. There was no alternative to this mechanical equipment with its inability to control applied voltage or power. This contrasts markedly with the YORK Medium Voltage Solid-State Starter which automatically maintains a predetermined current during starting, regardless of variations in line voltage or motor load, to give optimum acceleration without surges. Even with the addition of transformers, reactors, resistors and additional contactors, timers and relays, the mechanical controllers offer limited adjustment, no positive control during starting and impose an objectionable transition spike. Some also require modified motors. A field-installed, electromechanical compressor motor starter is available, selected for proper size and type for job requirements and in accordance with Johnson Controls Engineering Standard (R-1132) for Starters.

The most common failure mode of mechanical contactors is OFF. This occurs due to the coil open-circuiting or failure of a pole to make an electrical contact when it closes. However, failure in the ON mode is not completely uncommon and can be a more dramatic type of failure, particularly if this failure mode exists at the same time that equipment safety controls are demanding a shutdown.

**TABLE 2 - AVAILABILITY AND ADVANTAGES OF SOLID-STATE STARTERS**

MEDIUM VOLTAGE SOLID-STATE STARTER (FLOOR MOUNTED)	60 HZ				50HZ		
	2300V	3300V	4000V	4160V	2300V	3000V	3300V
	X	X	X	X	X	X	X
STARTER TYPE	ADVANTAGES						
SOLID-STATE STARTERS	SMOOTH, CONTROLLED START PROFILE UNIT MOUNTED, FACTORY WIRED AND TESTED (FOR LOW VOLTAGE APPLICATION UP TO 1050 AMPS) RUGGED AND RELIABLE WITH NO MOVING PARTS ADJUSTABLE ACCELERATION TIMES REDUCED COMPRESSOR SOUND LEVEL AT MOST OPERATIONAL CONDITIONS APPLICATION-SPECIFIC DESIGNS ENABLE SEAMLESS INTEGRATION WITH EQUIPMENT CONTROL PANEL AND BAS						

Note: For higher voltage contact Johnson Controls Sales Office for a Special Quote (SQ).

When contacts are “made,” the current builds up to its maximum value from zero, but when contacts are separated the current tends to flow through the gap thus formed and causes an arc. This arcing depends upon the voltage between the separating contacts. For medium voltage the use of vacuum contactors mitigates this problem somewhat by providing an environment to extinguish the arc. In the alternating current circuit, the separation of contacts may take place when the current is zero or maximum or at any value in between. An alternating current passes through zero and reverses its polarity twice during each cycle. If two or more contacts, one in each leg of a polyphase system, are separated simultaneously, the current values in each will vary. In a three-phase system, if one contact has zero current when opened, the other two contacts will have 86.6% of their maximum values, as an example. Additionally, when inductive circuits are broken, the voltage is increased at the contacts due to the counter (induced) EMF of the circuit. The instant the contacts separate, the voltage between them momentarily rises from zero to the maximum of the circuit, or higher if inductance is present in the circuit. In practice, every time the contacts close, they bounce. When they bounce, they arc. The arcing that occurs as the contacts make or break may result in rapid and excessive erosion of the contacts, causing prematurely short contact life.

## B. Types

YORK units are designed for use with the following types of electromechanical starters, here briefly described in Table 3.

**Across-the-Line (ACL)** – These are the simplest and lowest-cost starters available. They apply full voltage to the three motor leads at the instant of starting. Since inrush is 100% of LRA and starting torque is 100%, this is the roughest type of starting on the motor and driveline. In physical size, the ACL is the smallest of electromechanical starters and there is no transition surge. In most areas,

utility companies will not permit the use of this type of starter for unit-size motors because of their large current draw on startup.

**Auto-Transformer (AT)** – These starters are reduced-voltage starters. Transformers are used to step down the voltage to the motor during startup. The result is reduced inrush current and starting torque at the level of 42% or 64% depending upon whether 65% or 80% voltage taps are used.

They provide closed transition (with three-lead motors) with reduced line disturbance.

**Star-Delta Starters** – During starting, the motor is connected in a Star or Wye configuration. This reduces the voltage to the motor stator by a factor of three. This 1/3 voltage results in 1/3 current into the motor at start and 1/3 torque to the shaft. Centrifugal compressor starting torque requirements are low enough to allow the motor to start at 1/3 of full load torque. Star-Delta starting creates some stresses for the starter’s switchgear, building electrical system, power grid, and unit mechanical driveline. Although these stresses are 1/3 of the stresses generated by an ACL starter, they cause wear on the system. As a result, Johnson Controls recommends using a Solid State Starter instead of a Star-Delta starter.

## GENERAL ACCESSORIES AND MODIFICATIONS

### MEDIUM VOLTAGE MOTORS

Medium voltage motors (4160V/60Hz to 13800V/60Hz and 3300V/50Hz to 11000V/50Hz) are available for CYK units; Contact your Johnson Controls Sales Office for special rating.

**TABLE 3 – ELECTRO-MECHANICAL STARTER**

STARTER OPTIONS	LOW VOLTAGE / FREQUENCY												
LV ACROSS THE LINE (DOL) (FLOOR MOUNTED)	60HZ								50HZ				
	208V	230V	380V	440V	460V	480V	575V	600V	380V	400V	415V		
	X	X	X	X	X	X	X	X	X	X	X		
LV STAR-DELTA CLOSED (FLOOR MOUNTED)	60HZ								50HZ				
	208V	230V	380V	440V	460V	480V	575V	600V	380V	400V	415V		
	X	X	X	X	X	X	X	X	X	X	X		
STARTER OPTIONS	MEDIUM VOLTAGE / FREQUENCY												
MV ACROSS THE LINE (DOL) (FLOOR MOUNTED)	60HZ							50HZ					
	2300	3300	4000	4160	6000	6600	13800	2300	3000	3300	6600	10000	11000
	X	X	X	X	Y	Y	Y	X	X	X	Y	Y	Y
MV AUTOTRANSFORMER 65% (FLOOR MOUNTED)	60HZ							50HZ					
	2300	3300	4000	4160	6000	6600	13800	2300	3000	3300	6600	10000	11000
	X	X	X	X	Y	Y	Y	X	X*	X*	Y	Y	Y
MV AUTOTRANSFORMER 80% (FLOOR MOUNTED)	60HZ							50HZ					
	2300	3300	4000	4160	6000	6600	13800	2300	3000	3300	6600	10000	11000
	X	X	X	X	Y	Y	Y	X	X	X	Y	Y	Y

\* Not available with 5DJ motor / Y= available by Special Quote (SQ)

# Accessories and Modifications

## SPECIAL MOTORS ENCLOSURES

There are job applications, primarily in manufacturing, comfort cooling plants, and process applications, where more motor protection is required. Listed below are several alternatives. NOTE: Unit certification to UL by a third party could be affected. Contact your Johnson Controls sales office for a specific selection.

**Weather-Protected Type I Motors (WP-I)** – A Weather-Protected Type I motor is an open machine with its ventilating passages constructed to prevent the passage of a cylindrical rod  $\frac{3}{4}$ " in diameter.

This affords protection against intrusion of rodents and some types of debris. These are regularly used in the pulp industry and where grime is present.

**Weather-Protected Type II Motors (WP-II)** – A Weather-Protected Type II motor has, in addition to the enclosure defined for Weather-Protected Type I motor, ventilating passages at both intake and exhaust so arranged that high-velocity air and air-borne particles, blown into the motor, can be discharged without entering the internal ventilating passages leading directly to the electric parts of the machine itself. Space heaters are required with WP-II.

**Totally Enclosed Fan-Cooled Motors (TEFC)** – TEFC motors are used where the location is extremely dirty, dusty, or wet, both indoors and outdoors. A totally enclosed fan-cooled unit is enclosed to prevent the free exchange of air between the inside and outside of the case but not sufficiently enclosed as to be termed air-tight. It is air-cooled by means of a fully enclosed fan blowing cooling air over the outside of the motor. The fan is externally mounted on the motor shaft.

**Totally Enclosed Air-to-Air Cooled (TEAAC)** – TEAAC motors are used when the environment is dirty or corrosive. A TEAAC motor is a totally enclosed motor, cooled by circulating the internal air through an air-to-air heat exchanger.

**Totally Enclosed Water-to-Air Cooled (TEWAC)** – TEWAC motors are used when the environment is dirty or corrosive, in hazardous areas, or where minimum noise levels are required. A TEWAC motor is a totally enclosed machine which is cooled by circulating internal air which, in turn, is cooled by circulating water. It is provided with an internal water-cooled heat exchanger for cooling the internal air and fans, integral with the rotor shaft for circulating the internal air.

## BAS REMOTE CONTROL

Alternate network mediums and protocols may be accomplished with the addition of a protocol translator gateway. See Table 1 on pg. 9 for additional protocols.

## FACTORY INSULATION OF EVAPORATOR

Factory-applied thermal insulation of the flexible, closed-cell plastic type,  $\frac{3}{4}$ " (19 mm) thick is attached with vapor-proof cement to the evaporator shell, flow chamber, tube sheets, suction connection, and (as necessary) to the auxiliary tubing. The flash economizer (intercooler) operates near room temperature and does not require insulation. For all other projects, optional factory insulation on the flash economizer (intercooler) is available upon request. Not included is the insulation of compact waterboxes and nozzles. This insulation will normally prevent condensation in environments with relative humidities up to 75% and dry bulb temperatures ranging from 50° to 90°F (10° to 32.2°C).  $1\frac{1}{2}$ " (38 mm) thick insulation is also available for relative humidities up to 90% and dry bulb temperatures ranging from 50° to 90°F (10° to 32.2°C). For heat pump applications, the condenser can be ordered with optional factory insulation to minimize heat loss to the atmosphere.

## WATER FLANGES

Four 150 lb. ANSI raised-face flanges for condenser and evaporator water connections are factory-welded to water nozzles. Companion flanges, bolts, nuts and gaskets are not included.

## SPRING ISOLATION MOUNTING

Spring isolation mounting is available instead of standard isolation mounting pads when desired. Seven vertically restrained level-adjusting, spring-type vibration isolator assemblies with non-skid pads are provided for field-installation. Isolators are designed for one-inch (25 mm) deflection.

## MARINE WATER BOXES

Marine water boxes allow service access for cleaning of the heat exchanger tubes without the need to break the water piping. Bolted-on covers are arranged for convenient access. ANSI/AWWA C-606 nozzle connections are standard; flanges are optional. Marine water boxes are available for condenser and/or evaporator.

## HINGED WATERBOXES

Hinged waterboxes allow fast and safe service access for cleaning heat exchanger tubes. Hinged waterboxes on a non-nozzle end give access to the tubes without having to disconnect the water piping. Hinged waterboxes are available for condenser and/or evaporator for compact and marine waterboxes.

## KNOCK-DOWN SHIPMENT

The unit can be shipped knocked down into major sub-assemblies (evaporator, condenser, driveline, etc.) as required to rig into tight spaces. This is particularly convenient for existing buildings where equipment room access does not allow rigging a factory-packaged unit.



---

**REFRIGERANT ISOLATION VALVES**

Optional factory-installed isolation valves in the compressor discharge line and refrigerant liquid line are available. This allows isolation and storage of the refrigerant charge in the unit condenser during servicing, eliminating time-consuming transfers to remote storage vessels. Both valves are positive shut-off, assuring integrity of the storage system.

**REFRIGERANT STORAGE/RECYCLING SYSTEM**

A refrigerant storage/recycling system is a self-contained package consisting of a refrigerant compressor with oil separator, storage receiver, water-cooled condenser, filter drier and necessary valves and hoses to remove, replace and distill refrigerant. All necessary controls and safety devices are a permanent part of the system.

**TUBE AND/OR TUBE SHEET MATERIALS AND/OR WATER BOX COATING**

For condenser and/or evaporator for protection against aggressive water conditions. Alternate cupro-nickel or titanium tubes can be provided in lieu of standard copper. Tube sheets may be of the clad type. Epoxy coating may be applied to water boxes or to tubesheet and water boxes.

**SACRIFICIAL ZINC ANODES**

With mounting hardware for condenser and/or evaporator corrosion protection.

**HIGHER WATER CIRCUIT DWP**

Condenser and/or evaporator water circuit(s) DWP higher than the standard 150 psig (1034 barg) DWP.

**OUTDOOR AND/OR HAZARDOUS DUTY APPLICATIONS**

Necessary unit, control and control center modifications for Outdoor (NEMA-3 & 4) application in lieu of standard NEMA-1 construction. Suitable alternate surface preparation and protective coating systems also available.

**UNIT PERFORMANCE TEST**

Various operational conditions can be offered for Factory Performance Test. Please contact your local Johnson Controls Sales Representative for additional details. In case of Field Performance Test, refer to the PUBL-6286 and Form 160.82-TD1.

# Application Data

The following discussion is a user's guide in the application and installation of CYK units to ensure the reliable, trouble-free life for which this equipment was designed. While this guide is directed towards normal, water-chilling applications, the Johnson Controls sales representative can provide complete recommendations on other types of applications. If this is a Heat Pump application, refer to Form 160.00-AG1, Application Guide for Large Capacity Water-to-Water Heat Pumps for Centralized Plants.

## LOCATION

CYK units are virtually vibration free and may generally be located at any level in a building where the construction will support the total system operating weight.

The unit site must be a floor, mounting pad or foundation which is level within 1/4" (6.4 mm) and capable of supporting the operating weight of the unit.

Sufficient clearance to permit normal service and maintenance work should be provided all around and above the unit. Additional space should be provided at one end of the unit to permit cleaning of evaporator and condenser tubes as required. A doorway or other properly located opening may be used.

The unit should be installed in an indoor location where temperatures range from 40°F to 104°F (4.4°C to 40°C).

## WATER CIRCUITS

**Flow Rate** – For normal water chilling duty, evaporator and condenser flow rates are permitted at water velocity levels in the heat exchangers tubes of between 3.0 ft/sec and 12 ft/sec (0.91 m/s and 3.66 m/s). Variable flow applications are possible, and initial unit selections should be made accordingly to allow proper range of flow while maintaining the minimum velocity noted above. Variable flow in the condenser is not recommended, as it generally raises the energy consumption of the system by keeping the condenser pressure high in the unit. Additionally, the rate of fouling in the condenser will increase at lower water velocities associated with variable flow, raising system maintenance costs. Cooling towers typically have narrow ranges of operation with respect to flow rates, and will be more effective with full design flow. Contact Johnson Controls Sales for specific flow limits.

**Water Quality** – The practical and economical application of liquid units requires that the quality of the water supply for the condenser and evaporator be analyzed by a water treatment specialist. Water quality may affect the performance of any unit through corrosion, deposition of heat-resistant scale, sedimentation or organic growth. These will degrade unit performance and increase operating and maintenance costs. Normally, performance may

be maintained by corrective water treatment and periodic cleaning of tubes. If water conditions exist which cannot be corrected by proper water treatment, it may be necessary to provide a larger allowance for fouling, and/or to specify special materials of construction.

**General Piping** – All chilled water and condenser water piping should be designed and installed in accordance with accepted piping practice. Chilled water and condenser water pumps should be located to discharge through the unit to assure positive pressure and flow through the unit. Piping should include offsets to provide flexibility and should be arranged to prevent drainage of water from the evaporator and condenser when the pumps are shut off. Piping should be adequately supported and braced independently of the unit to avoid the imposition of strain on unit components. Hangers must allow for alignment of the pipe. Isolators in the piping and in the hangers are highly desirable in achieving sound and vibration control.

**Convenience Considerations** – To facilitate the performance of routine maintenance work, some or all of the following steps may be taken by the purchaser. Evaporator and condenser water boxes are equipped with plugged vent and drain connections. If desired, vent and drain valves may be installed with or without piping to an open drain. Pressure gauges with stop cocks and stop valves may be installed in the inlets and outlets of the condenser and chilled water line as close as possible to the unit. An overhead monorail or beam may be used to facilitate servicing.

**Connections** – The standard unit is designed for 150 psig (1034 kPA) design working pressure in both the chilled water and condenser water circuits. The connections (water nozzles) to these circuits are furnished with grooves for ANSI/AWWA C-606 couplings. Piping should be arranged for ease of disassembly at the unit for tube cleaning. All water piping should be thoroughly cleaned of all dirt and debris before final connections are made to the unit.

**Condenser Water Strainer** – A water strainer of maximum 1/8" (3mm) perforated holes is recommended to be field installed in the refrigerant condenser water inlet line as close as possible to the unit. If located close enough to the unit, the condenser water pump may be protected by the same strainer. The loss or severe reduction of water flow due to blockage could seriously impair the unit's performance.

## MULTIPLE UNITS

**Selection** – Many applications require multiple units to meet the total capacity requirements as well as to provide flexibility and some degree of protection against

equipment shutdown. There are several common unit arrangements for this type of application. The CYK unit has been designed to be readily adapted to the requirements of these various arrangements.

**Parallel Arrangement** (Refer to Fig. 1) – Units may be applied in multiples with chilled and condenser water circuits connected in parallel between the units. Fig. 1 represents a parallel arrangement with two units. Parallel unit arrangements may consist of equally or unequally sized units. When multiple units are in operation, they will load and unload at equal percentages of design full load for the unit.

Depending on the number of units and operating characteristics of the units, loading and unloading schemes should be designed to optimize the overall efficiency of the unit plant. It is recommended to use an evaporator by-pass piping arrangement to bypass fluid around evaporator of any unit which has cycled off at reduced load conditions. It is also recommended to alternate the unit cycling order to equalize unit starts and run hours.

#### REFRIGERANT RELIEF PIPING

Each unit is equipped with dual pressure relief valves on the condenser, dual relief valves on the evaporator and dual relief valves on the flash economizer (intercooler). The dual relief valves are redundant and allow changing of either valve while the unit is fully charged. The purpose of the relief valves is to quickly relieve excess pressure of the refrigerant charge to the atmosphere, as a safety precaution in the event of an emergency such as fire.

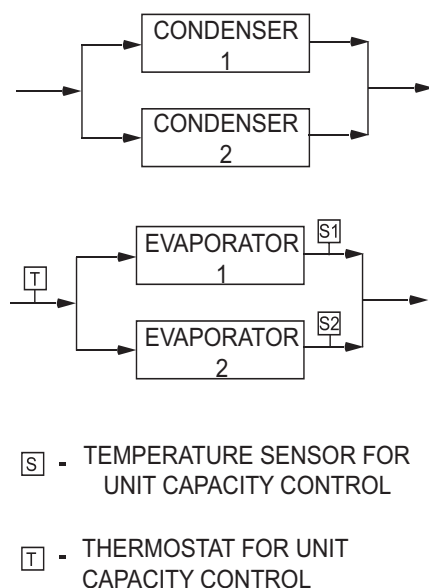

**FIG. 1 – PARALLEL EVAPORATORS  
PARALLEL CONDENSERS**

JOHNSON CONTROLS

They are set to relieve at an internal pressure as noted on the pressure vessel data plate, and are provided in accordance with ASHRAE 15 safety code and ASME or applicable pressure vessel code.

Sized to the requirements of applicable codes, a vent line must run from the relief device to the outside of the building. This refrigerant relief piping must include a cleanable, vertical-leg dirt trap to catch vent-stack condensation. Vent piping must be arranged to avoid imposing a strain on the relief connection and should include one flexible connection.

#### SOUND AND VIBRATION CONSIDERATIONS

A CYK unit is not a source of objectionable sound and vibration in normal air conditioning applications. Neoprene isolation mounts are furnished as standard with each unit. Optional level-adjusting spring isolator assemblies designed for 1" (25 mm) static deflection are available from Johnson Controls.

CYK unit sound pressure level ratings will be furnished on request.

Control of sound and vibration transmission must be taken into account in the equipment room construction as well as in the selection and installation of the equipment.

#### THERMAL INSULATION

No appreciable operating economy can be achieved by thermally insulating the unit. However, the unit's cold surfaces should be insulated with a vapor barrier insulation sufficient to prevent condensation. A unit can be factory insulated with 3/4" (19 mm) or 1-1/2" (38 mm) thick insulation, as an option. This insulation will normally prevent condensation in environments with dry bulb temperatures of 50°F to 90°F (10°C to 32°C) and relative humidities up to 75% [3/4" (19 mm) thickness] or 90% [1-1/2" (38 mm) thickness]. For heat pump applications where the condenser operating temperature is above 140°F (60°C), thermal insulation is also recommended. The insulation surface is flexible and reasonably resistant to wear. It is intended for a unit installed indoors and, therefore, no protective covering of the insulation is usually required. If insulation is applied to the water boxes at the jobsite, it must be removable to permit access to the tubes for routine maintenance. For heat pump applications the condenser can be ordered with optional factory insulation to minimize heat loss to the atmosphere.

#### VENTILATION

The ASHRAE Standard 15 Safety Code for Mechanical Refrigeration requires that all machinery rooms be vented to the outdoors using mechanical ventilation by one or more power-driven fans. This standard, plus National

## Application Data

Fire Protection Association Standard 90A, state, local and any other related codes should be reviewed for specific requirements. Since the CYK unit motor is air-cooled, ventilation should allow for the removal of heat from the motor.

In addition, the ASHRAE Standard 15 requires a refrigerant vapor detector to be employed for all refrigerants. It is to be located in an area where refrigerant from a leak would be likely to concentrate. An alarm is to be activated and the mechanical ventilation started at a value no greater than the TLV (Threshold Limit Value) of the refrigerant.

### ELECTRICAL CONSIDERATIONS

**Motor Voltage** – Low voltage motors (200 to 600 volts) are furnished with six leads. Medium voltage (2300 to 4160 volts) motors have three leads. Motor circuit conductor size must be in accordance with the National Electrical Code (NEC), or other applicable codes, for the motor full load amperes (FLA). Flexible conduit should be used for the last several feet to the unit in order to provide vibration isolation. Table 4 lists the allowable variation in voltage supplied to the unit motor. The unit name plate is stamped with the specific motor voltage, and frequency for the appropriate motor.

**Starters** – Electro-mechanical starters must be furnished in accordance with Johnson Controls Standard Specifications (R-1177). This will ensure that starter components, controls, circuits, and terminal markings will be suitable for required overall system performance.

**Oil Pump Power Supply** – A separate 3-phase power supply with a fused disconnect for the factory mounted oil pump variable speed drive is required. Power can also be supplied through an electro-mechanical starter. A 115 volt, single phase, control power transformer is provided in the oil pump drive panel to provide power to the Unit Control Panel.

**Copper Conductors** – Only copper conductors should be connected to compressor motors and starters. Aluminum conductors have proven to be unsatisfactory when connected to copper lugs. Aluminum oxide and the difference in thermal conductivity between copper and aluminum cannot guarantee the required tight connection over a long period of time.

**Power Factor Correction Capacitors** – Capacitors can be applied to a unit for the purpose of power factor correction. For remote-mounted electro-mechanical starters, the capacitors should be located on the load-side of the starter. The capacitors must be sized and installed to meet the National Electrical Code and be verified by Johnson Controls.

**TABLE 4 – MOTOR VOLTAGE VARIATIONS**

FREQ.	RATED VOLTAGE	NAMEPLATE VOLTAGE*	OPERATING VOLTAGE	
			MIN.	MAX.
60HZ	208	208	180	220
	230	220/240	208	254
	380	380	342	415
	460	440/460/480	414	508
	575	575/600	520	635
	2300	2300	2,070	2,530
	3300	3300	2,970	3,630
	4000	4000/4160	3,600	4,576
50HZ	380	380/400	342	423
	415	415	374	440
	3300	3300	2,970	3,630

\*For motor voltage above 4160V/60Hz and 3300V/50HZ contact the JCI Sales Office for a specific selection.

**Ampacity on Load Side of Starter** – Electrical power wire size to the unit is based on the minimum unit ampacity. For remote starters, the National Electrical Code defines the calculation of ampacity, as summarized below. More specific information on actual amperage ratings will be supplied with the submittal drawings.

- Six-lead type of starting (Star-Delta)  
Minimum circuit ampacity per conductor (1 of 6):  
Ampacity = .721 x compressor motor amps.
- Three-lead type of starting  
(Across-the-Line, Autotransformer and Primary Reactor)  
Minimum circuit ampacity per conductor (1 of 3):  
Ampacity = 1.25 x compressor motor amps.

**Ampacity on Line-Side of Starter** – The only additional load on the circuit for the unit would be oil pump supply unless they are supplied by a separate source.

- Minimum Circuit Ampacity = 125% of compressor motor amps + FLA of all other loads on the circuit.

**Branch Circuit Overcurrent Protection** – The branch circuit overcurrent protection device(s) should be a time-delay type, with a minimum rating equal to the next standard fuse/breaker rating above the calculated value. It is calculated taking into account the compressor motor amps and may also include control transformer and oil pump motor. Refer to submittal drawings for the specific calculations for each application.

### MOTOR ELECTRICAL DATA

The smallest motor available which equals or exceeds the Input power (KW) from the unit rating program is selected from Tables 5 and 6. The full load amperes (FLA) listed

**TABLE 5 – PHASE/VOLTAGE**

AVAILABLE 3 PHASE VOLTAGES	
FREQUENCY	VOLTAGE
60HZ	208
	220
	230
	240
	380
	440
	460
	480
	575
	600
50HZ	380
	400
	415

in the tables are maximum values and correspond to the maximum motor KW listed. When the input power (kW) is less than maximum motor KW, the FLA should be reduced per the following equation:

$$\text{FLA} = \frac{\text{Motor kW}}{\text{Max. Motor kW}} \times \text{Max. Motor FLA}$$

The benefit from the FLA correction is the possible use of smaller power wiring and/or starter size.

The locked rotor amperes (LRA) are read directly from Tables 4 and 5 for specific Motor Code and voltage. This is because the LRA is dependent only on motor size and voltage and is independent of input power (KW).

Inrush amperes (IRA) depend on LRA and the type of starter applied. The inrush can be calculated using a percentage of LRA shown in Table 8.

# Application Data

TABLE 6 – 60 Hz ELECTRICAL DATA

MOTORCODE	CF	CG	CH	CJ	CK	CL	CM	CN	CP	CR	CS	CT	CU	CV	CW	
KW (MAX)	125	144	161	190	214	240	257	276	302	333	368	395	435	478	514	
SHAFT HPFL.	154	177	201	237	270	302	327	351	385	424	468	503	554	608	655	
EFF. - %	92	92	93	93	94	94	95	95	95	95	95	95	95	95	95	
VOLTS			AMPERES (MAX.)													
200	FLA	405	465	527	618	707	787	921	1,014	1,085	1,208	—	—	—	—	—
	LRA	2,598	3,111	3,810	4,550	4,900	5,470	5,780	7,350	7,794	—	—	—	—	—	—
208	FLA	389	447	507	594	680	757	799	886	975	1,043	1,162	—	—	—	—
	LRA	2,702	3,235	3,235	3,962	4,732	5,096	5,689	6,011	6,011	7,644	8,106	—	—	—	—
230	FLA	352	404	464	540	610	685	749	804	882	944	1,050	1,130	—	—	—
	LRA	2,598	2,598	2,865	3,460	3,788	4,260	4,755	5,162	5,780	5,780	6,900	7,400	—	—	—
240	FLA	337	387	445	518	585	656	718	771	845	905	1,006	1,083	—	—	—
	LRA	2,711	2,711	3,120	3,610	3,953	4,445	4,962	5,386	6,031	6,031	7,200	7,722	—	—	—
380	FLA	217	249	285	336	378	421	453	487	534	571	636	684	756	817	879
	LRA	1,385	1,385	1,730	2,153	2,500	2,577	2,955	3,254	3,637	3,810	4,179	4,480	4,671	5,326	5,780
41.6	FLA	199	228	260	307	346	385	412	445	488	522	581	625	691	747	810
	LRA	1,385	1,385	1,638	1,967	2,190	2,356	2,700	2,976	3,536	3,637	3,810	3,810	4,270	4,869	5,640
440	FLA	184	211	238	281	319	358	392	397	461	493	549	591	646	706	579
	LRA	1,177	1,301	1,320	1,655	1,865	2,037	2,485	2,485	2,976	2,976	3,300	3,644	3,644	4,209	4,783
460	FLA	176	202	228	269	305	342	375	380	441	472	525	565	618	675	726
	LRA	1,230	1,360	1,380	1,730	1,950	2,130	2,598	2,598	3,111	3,111	3,450	3,810	3,810	4,400	5,000
480	FLA	169	194	219	258	292	328	359	364	423	452	503	541	592	647	696
	LRA	1,283	1,419	1,440	1,805	2,053	2,223	2,711	2,711	3,246	3,246	3,600	3,976	3,976	4,591	5,217
575	FLA	141	162	185	216	250	247	300	318	353	377	420	452	500	540	581
	LRA	909	909	1,100	1,384	1,556	1,700	1,900	2,066	2,078	2,413	2,760	2,960	3,089	3,550	4,039
600	FLA	135	155	177	207	240	263	288	305	338	361	403	433	479	518	557
	LRA	949	949	1,148	1,444	1,624	1,774	1,983	2,156	2,168	2,518	2,880	3,089	3,223	3,704	4,215
2300	FLA	36	41	46	55	63	70	74	80	87	95	106	113	124	135	146
	LRA	240	267	298	340	397	435	480	520	530	590	669	719	791	867	935
3300	FLA	25	29	33	39	44	49	52	55	61	67	73	79	86	94	102
	LRA	160	175	210	240	280	310	310	343	382	415	466	501	551	576	652
4000	FLA	21	24	27	32	36	40	43	46	50	55	60	65	71	78	84
	LRA	135	154	166	195	230	240	270	283	315	340	384	413	455	499	538
4160	FLA	20	23	26	30	34	38	41	44	48	52	58	63	68	75	81
	LRA	140	160	173	203	239	250	270	294	328	328	399	430	473	519	560

TABLE 6A – 50 Hz ELECTRICAL DATA

MOTORCODE	5CC	5CD	5CE	5CF	5CG	5CH	5CI	5CJ	5CK	5CL	5CM	5CN	5CO	5CP	5CQ	5CR	5CS	
KW (MAX)	121	136	160	180	201	215	231	254	280	309	332	366	402	432	455	481	518	
SHAFT HPFL.	148	168	198	225	252	272	292	321	353	390	419	462	507	546	575	608	658	
EFF.-%FL PF	91.1	92.4	92.4	93.4	93.4	94.2	94.2	94.2	94.2	94.2	94.2	94.2	94.2	94.2	94.2	94.2	94.7	
	0.86	0.86	0.86	0.86	0.86	0.86	0.86	0.86	0.87	0.87	0.87	0.87	0.87	0.87	0.87	0.87	0.88	
VOLTS			AMPERES (MAX.)															
346	FLA	224	258	302	340	380	417	437	481	528	584	630	692	578	816	860	909	982
	LRA	1,385	1,721	1,790	2,208	2,467	2,598	2,840	3,081	3,350	3,706	3,810	4,177	4,830	4,944	5,373	5,780	5,780
380	FLA	204	235	275	309	346	379	398	438	481	532	572	630	690	743	783	841	895
	LRA	1,385	1,385	1,640	1,890	2,144	2,464	2,590	2,806	3,050	3,375	3,700	3,810	4,400	4,500	4,892	5,600	5,491
400	FLA	194	223	261	294	329	360	378	416	457	505	543	599	656	706	744	799	850
	LRA	1,458	1,458	1,726	1,990	2,257	2,594	2,726	2,954	3,211	3,553	3,895	4,011	4,632	4,737	5,149	5,895	5,780
415	FLA	187	215	252	284	317	347	364	401	441	487	526	577	632	680	717	764	819
	LRA	1,283	1,385	1,490	1,700	2,031	2,175	2,366	2,569	2,794	3,088	3,402	3,478	3,810	4,117	4,480	5,130	5,108
3300	FLA	24	27	32	36	41	44	47	50	56	62	66	73	80	87	91	96	103
	LRA	159	162	209	236	241	274	294	318	317	388	423	455	499	516	572	614	644

CX	CY	CZ	CA	CB	DA	DB	DC	DD	DE	DF	DH	DJ	DK	DL	MOTORCODE	
542	578	617	660	703	781	859	937	1,015	1,093	1,171	1,359	1,554	1748	1942	KW (MAX.) SHAFT HPFL EFF.-%**	
690	740	790	845	900	1,000	1,100	1,200	1,300	1,400	1,500	1,750	2,000	2250	2500		
95	95.5	95.5	95.5	95.5	95.5	95.5	95.5	95.5	95.5	95.5	96	96	96	96		
AMPERES (MAX.)															VOLTS	
—	—	—	—	—	—	—	—	—	—	—	—	—	—	—	FLA	200
—	—	—	—	—	—	—	—	—	—	—	—	—	—	—	LRA	
—	—	—	—	—	—	—	—	—	—	—	—	—	—	—	FLA	208
—	—	—	—	—	—	—	—	—	—	—	—	—	—	—	LRA	
—	—	—	—	—	—	—	—	—	—	—	—	—	—	—	FLA	230
—	—	—	—	—	—	—	—	—	—	—	—	—	—	—	LRA	
—	—	—	—	—	—	—	—	—	—	—	—	—	—	—	FLA	240
—	—	—	—	—	—	—	—	—	—	—	—	—	—	—	LRA	
942	997	1065	1,126	1,200	1,364	1,500	1,636	—	—	—	—	—	—	—	FLA	380
6,782	5,780	6,644	7,106	7,513	7,794	8,491	9,431	—	—	—	—	—	—	—	LRA	
860	911	973	1,029	1,096	1,246	1,370	1,495	—	—	—	—	—	—	—	FLA	416
5,780	5,694	6,069	6,489	6,863	7,120	7,755	8,608	—	—	—	—	—	—	—	LRA	
813	861	920	973	1,036	1,178	1,295	1,413	—	—	—	—	—	—	—	FLA	440
5,357	4,783	5,249	5,529	5,529	6,160	6,709	7,455	—	—	—	—	—	—	—	LRA	
778	824	880	931	991	1,127	1,239	1,352	—	—	—	—	—	—	—	FLA	460
5,600	5,000	5,488	5,780	5,780	6,440	7,014	7,794	—	—	—	—	—	—	—	LRA	
746	790	843	892	950	1,080	1,187	1,296	—	—	—	—	—	—	—	FLA	480
5,843	5,217	5,727	6,031	6,031	6,720	7,319	8,133	—	—	—	—	—	—	—	LRA	
622	659	704	744	793	901	991	1,081	—	—	—	—	—	—	—	FLA	575
4,440	4,300	4,200	4,694	4,963	5,148	5,610	6,232	—	—	—	—	—	—	—	LRA	
596	632	675	713	760	863	950	1,036	—	—	—	—	—	—	—	FLA	600
4,633	4,484	4,383	4,898	5,179	5,372	5,854	6,503	—	—	—	—	—	—	—	LRA	
154	165	176	186	198	225	248	267	290	312	334	389	438	493	548	FLA	2,300
960	1,008	1,100	1,172	1,230	1,234	1,592	1,592	1,592	2,031	2,031	2,390	2,879	2908	3012	LRA	
108	115	123	130	138	157	173	186	202	217	233	271	306	344	382	FLA	3,300
682	719	744	744	858	861	1,110	1,110	1,110	1,416	1,416	1,661	2,011	2027	2100	LRA	
89	95	101	107	114	130	143	154	166	179	192	224	252	283	315	FLA	4,000
540	554	631	674	713	715	923	923	923	1,177	1,177	1,386	1,669	1672	1732	LRA	
85	91	97	103	110	125	137	149	160	172	185	215	242	273	303	FLA	4,160
562	576	656	701	742	744	960	960	960	1,224	1,224	1,441	1,736	1608	1666	LRA	

5CT	5CU	5CV	5CW	5CX	5DA	5DB	5DC	5DD	5DE	5DF	5DG	5DH	*5DJ	5DK	5DL	MOTORCODE	
554	591	630	669	709	785	863	942	1,015	1,093	1,171	1,288	1,360	1,554	1,748	1,942	KW(MAX.) SHAFT HPFL EFF.-%**FL PF**	
704	750	800	850	900	1,000	1,100	1,200	1,300	1,400	1,500	1,650	1,750	2,000	2,250	2,500		
94.7	94.7	94.7	94.7	94.7	95	95	95	95.5	95.5	95.5	95.5	96	96	96	96		
0.88	0.89	0.89	0.89	0.89	0.88	0.87	0.88	0.88	0.88	0.88	0.88	0.89	0.89	0.89	0.89		
VOLTS		AMPERES (MAX.)															
1,051	1,107	1,181	1,255	1,329	1,488	1,656	—	—	—	—	—	—	—	—	—	FLA	346
6,615	6,931	7,356	7,794	8,319	8,559	9,346	—	—	—	—	—	—	—	—	—	LRA	
957	1,008	1,075	1,143	1,210	1,355	1,508	—	—	—	—	—	—	—	—	—	FLA	380
5,491	6,313	6,694	7,113	7,404	7,794	8,511	—	—	—	—	—	—	—	—	—	LRA	
909	958	1,021	1,086	1,150	1,287	1,433	—	—	—	—	—	—	—	—	—	FLA	400
5,780	6,645	7,046	7,487	7,794	8,204	8,959	—	—	—	—	—	—	—	—	—	LRA	
876	923	985	1,046	1,108	1,241	1,381	—	—	—	—	—	—	—	—	—	FLA	415
5,512	5,780	6,131	6,513	6,938	7,138	7,794	—	—	—	—	—	—	—	—	—	LRA	
110	116	124	132	139	156	174	187	202	217	233	256	267	306	344	382	FLA	3,300
693	725	744	819	875	871	1,135	1,135	1,135	1,415	1,415	1,415	1,667	1,591	2,231	2,481	LRA	

\*Min. reduced voltage tap 80%.

\*\* High voltage and special motor designs may not meet efficiency and P. F. shown for standard motors

# Application Data

**TABLE 7 - 60 HZ ELECTRICAL DATA - PREMIUM EFFICIENCY**

MOTOR CODE	EF	EG	EH	EJ	EK	EL	EM	EN	EP	ER	ES	ET	EU	EV	
SHAFT HP (MAX)	154	177	201	237	270	302	327	351	385	424	468	503	554	608	
INPUT KW (MAX)	122	139	158	185	211	236	256	274	300	330	364	392	431	473	
F.L. EFF. - %	94.5	95	95	95.4	95.4	95.4	95.4	95.4	95.8	95.8	95.8	95.8	95.8	95.8	
F.L. POWER FACTOR	0.88	0.88	0.88	0.88	0.88	0.88	0.88	0.88	0.88	0.88	0.88	0.88	0.88	0.88	
VOLTS	AMPERES (MAX.)														
200	FLA	399	456	518	608	692	774	838	900	983	1083	1195	-	-	-
	LRA	2598	3128	3128	3979	4550	4900	5470	5865	5865	7350	7935	-	-	-
208	FLA	383	438	498	584	666	745	806	865	945	1041	1149	-	-	-
	LRA	2702	3235	3235	4138	4732	5096	5689	6100	6100	7644	8252	-	-	-
230	FLA	347	396	450	528	602	673	729	783	855	941	1039	1117	-	-
	LRA	2598	2720	2865	3460	3788	4260	4755	5162	5780	6200	6900	8513	-	-
240	FLA	332	380	431	506	577	645	699	750	819	902	996	1070	-	-
	LRA	2711	2838	2990	3610	3953	4445	4962	5386	6031	6470	7200	8883	-	-
380	FLA	210	240	272	320	364	408	441	474	517	570	629	676	745	817
	LRA	1385	1646	1730	2153	2500	2578	2955	3254	3637	3810	4179	4480	4671	5326
416	FLA	192	219	249	292	333	372	403	433	473	521	575	617	680	746
	LRA	1385	1504	1638	1967	2190	2356	2700	2976	3536	3637	3815	3815	4270	4869
440	FLA	181	207	235	276	315	352	381	409	447	492	543	584	643	706
	LRA	1177	1301	1320	1655	1865	2037	2485	2485	2976	2976	3300	3348	3644	4209
460	FLA	173	198	225	264	301	337	365	391	427	471	520	558	615	675
	LRA	1230	1360	1380	1730	1950	2130	2598	2598	3111	3111	3450	3500	3810	4400
480	FLA	166	190	216	253	288	323	349	375	410	451	498	535	589	647
	LRA	1283	1419	1440	1805	2035	2223	2711	2711	3246	3246	3600	3652	3976	4591
575	FLA	139	159	180	211	241	269	292	313	342	377	416	447	492	540
	LRA	909	1088	1100	1384	1556	1704	1900	2066	2078	2413	2760	2960	3089	3550
600	FLA	133	152	173	203	231	258	279	300	328	361	398	428	472	517
	LRA	949	1135	1148	1444	1624	1778	1983	2156	2168	2518	2880	3089	3223	3704

**TABLE 7A - 50 HZ ELECTRICAL DATA - PREMIUM EFFICIENCY**

MOTOR CODE	5EC	5ED	5EE	5EF	5EG	5EH	5EI	5EJ	5EK	5EL	5EM	5EN	5EO	
SHAFT HP (MAX)	148	168	198	225	252	272	292	321	353	390	419	462	507	
INPUT KW (MAX)	117	133	156	177	198	214	229	252	277	305	328	361	396	
F.L. EFF. - %	94.3	94.5	94.7	94.9	95	95	95	95	95	95.4	95.4	95.4	95.4	
F.L. POWER FACTOR	0.88	0.88	0.88	0.88	0.88	0.88	0.88	0.88	0.88	0.88	0.88	0.88	0.88	
VOLTS	AMPERES (MAX.)													
346	FLA	222	251	296	335	375	405	435	478	525	578	621	685	751
	LRA	1521	1721	1790	2208	2467	2706	2840	3081	3350	3706	3810	4177	4830
380	FLA	202	229	269	305	342	369	396	435	478	526	565	623	684
	LRA	1385	1385	1640	1890	2144	2464	2590	2806	3050	3375	3700	3810	4400
400	FLA	192	217	256	290	324	350	376	413	454	500	537	592	650
	LRA	1458	1458	1726	1989	2257	2594	2726	2954	3211	3533	3895	4011	4632
415	FLA	185	210	246	280	313	338	362	398	438	482	518	571	627
	LRA	1283	1385	1502	1700	2031	2175	2366	2569	2794	3088	3402	3478	4027



**TABLE 8 – MOTOR STARTERS**

TYPE STARTER	SOLID STATE STARTER	STAR DELTA	AUTO TRANSFORMER			ACROSS-THE-LINE	PRIMARY REACTOR	
			VOLTAGE	MEDIUM	LOW		LOW	LOW/MEDIUM
60 HZ	2300-4160	200-600	200-600	200-4160	200-4160	200-4160	2300-4160	2300-4160
50 HZ	3300	380-415	380-415	380-3300	380-3300	380-3300	2300-3300	2300-3300
TRANSITION% TAP INRUSH AS A % OF LRA	—	CLOSED	CLOSED	CLOSED	CLOSED	—	CLOSED	CLOSED
	—	—	57.7	65	80	—	65	80
	45	33	33	42.3	64	100	65	80

**NOTE:**

1. For motor starters above 4160/60Hz and 3300/50Hz contact your Johnson Controls Sales Office for a specific selection
2. Inrush less than 100% of full load amps (FLA).

**TABLE 9 – MEDIUM VOLTAGE FLOOR MOUNTED SOLID-STATE STARTER MODELS**

MODEL FLOOR MOUNTED MV-SSS	MAX. FLA	MAX. LRA
36" CABINET UNIT MODEL REFERENCE CHART		
MVSS0853R_042-V	42	1896
MVSS0853R_050-V	50	1896
MVSS0853R_065-V	65	1896
MVSS0853R_095-V	95	1896
MVSS0853R_105-V	105	1896
MVSS0853R_140-V	140	1896
MVSS0853R_190-V	190	1896
MVSS0853R_280-V	280	1896
MVSS0853R_310-V	310	1896
MVSS0853R_360-V	360	1896
MVSS1708R_360-V	360	3796
72" CABINET UNIT MODEL REFERENCE CHART		
MVSS1708R_550-V	550	3796

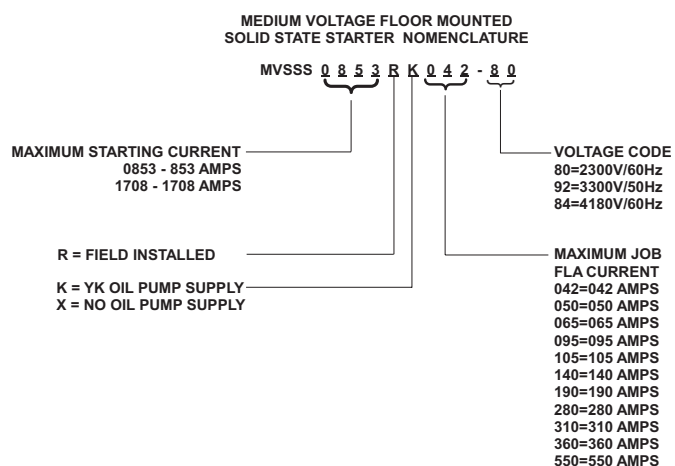

# Application Data

**TABLE 10 – CYK AUXILIARY POWER SUPPLY PANEL**

VOLTS-PH-HZ	MINIMUM CIRCUIT AMPACITY AMPS	MAXIMUM FUSE SIZE AMPS	FULL LOAD AMPS
200-3-60	29.5	36	27.4
208-3-60	28.4	35	26.3
220-3-60	26.8	33	24.9
230-3-60	25.7	31	23.8
240-3-60	24.6	30	22.8
380-3-60	15.5	19	14.4
416-3-60	14.2	17	13.2
440-3-60	13.4	16	12.4
460-3-60	12.8	16	11.9
480-3-60	12.3	15	11.4
550-3-60	10.7	13	10.0
575-3-60	10.3	12	9.5
600-3-60	9.8	12	9.1
346-3-50	17.1	21	15.8
380-3-50	15.5	19	14.4
400-3-50	14.8	18	13.7
415-3-50	14.2	17	13.2

**TABLE 11 – AVAILABLE CYK COMPRESSOR/SHELL/MOTOR COMBINATIONS**

LOW SIDE COMP CODES	HIGH SIDE COMP CODES	EVAPORATOR CODES	CONDENSER CODES	LOW SIDE MOTOR CODES		HIGH SIDE MOTOR CODES	
				60HZ	50HZ	60HZ	50HZ
P8	G4,H0	K2 TO K7, KP TO KX	K2 TO K4, KP TO KS	EH/CH TO CA	5EE/5CE TO 5CW	CH TO DD	5EE/5CE TO 5DC
P9	G4,H0	K2 TO K7, KP TO KX	K2 TO K4, KP TO KS	EH/CH TO CA	5EE/5CE TO 5CW	CH TO DD	5EE/5CE TO 5DC
H9	G4,H0	K2 TO K7, KP TO KX	K2 TO K4, KP TO KS	EH/CH TO CA	5EE/5CE TO 5CW	CH TO DD	5EE/5CE TO 5DC
K1	H0,H1,H2	N2 TO N4, NQ TO NS	N2 TO N4, NP TO NS	EN/CN TO DD	5EN/5CN TO 5DD	CH TO DD	5EE/5CE TO 5DD
K2	H0,H1,H2	N2 TO N4, NQ TO NS	N2 TO N4, NP TO NS	EN/CN TO DD	5EN/5CN TO 5DD	CH TO DD	5EE/5CE TO 5DD
K3	U1,U2	Q2 TO Q4, QQ TO QV	Q2 TO Q4, QQ TO QV, R2 TO R7, RP TO RV	DA TO DJ	5CR TO 5DJ	CS TO DJ	5EO/5CO TO 5DJ
		S3 TO S7, SQ TO SV, W1 TO W6, WP TO WT	S2 TO S4, SQ TO SS, W1 TO W4, WQ TO WS				
		Q2 TO Q4, QQ TO QV	Q2 TO Q4, QQ TO QS				
K4	U1,U2	R2 TO R7, RP TO RV	R2 TO R4, RQ TO RS	DA TO DJ	5CR TO 5DJ	CS TO DJ	5EO/5CO TO 5DJ
		S3 TO S7, SQ TO SV	S2 TO S4, SQ TO SS				
		W1 TO W6, WP TO WT	W1 TO W4, WQ TO WS				
K7	U1,U2	W1 TO W6, WP TO WT	W1 TO W6, WP TO WT	DD TO DL	5DD TO 5DL	CS TO DJ	5EO/5CO TO 5DJ
		X2 TO X4, XQ TO XS	X2 TO X4, XQ TO XS				
		Z1 TO Z4, ZQ TO ZS	Z1 TO Z4, ZQ TO ZS				

# Overall Unit Arrangement

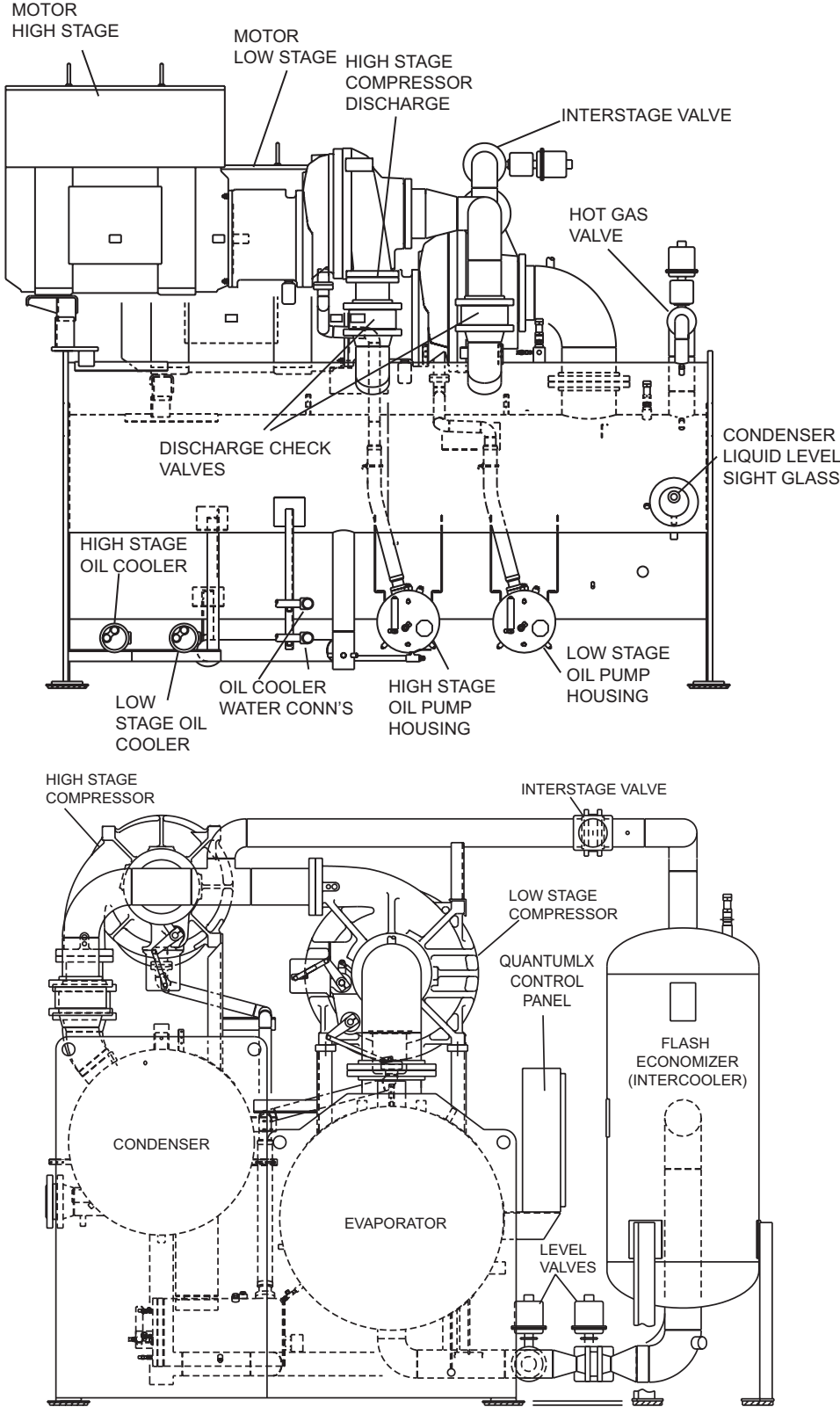

FIG. 2 – UNIT ARRANGEMENT

# Compact Nozzle Arrangements

## EVAPORATOR COMPACT WATER BOXES

SHELL CODES	1 PASS					2 PASS					3 PASS				
	SIZE	150LB		300LB		SIZE	150LB		300LB		SIZE	150LB		300LB	
		IN / OUT	FIG.	IN / OUT	FIG.		IN / OUT	FIG.	IN / OUT	FIG.		IN / OUT	FIG.	IN / OUT	FIG.
K	16	A / H	3	A / H	3	12	C / B	4	C / B	4	10	G / N	6	G / N	6
		H / A		H / A			K / J		K / J			P / F		P / F	
N, QQ, QR, QS, Q2, Q3, Q4	18	A / H	7	A / H	3	14	B / C	8	C / B	4	12	F / N	9	G / N	6
		H / A		H / A			K / J		K / J			N / F		P / F	
							J / K								
							K / J								
QT, QV	20	A / H	7	A / H	3	16	B / C	8	C / B	4	12	F / N	9	G / N	6
		H / A		H / A			K / J		K / J			N / F		P / F	
							J / K								
							K / J								
R, S, W, X, Z	20	A / H	7	A / H	3	18	B / C	8	E / B	5	14	F / N	9	G / N	6
		H / A		H / A			M / J		N / F			P / F			
							J / K								
							K / J								

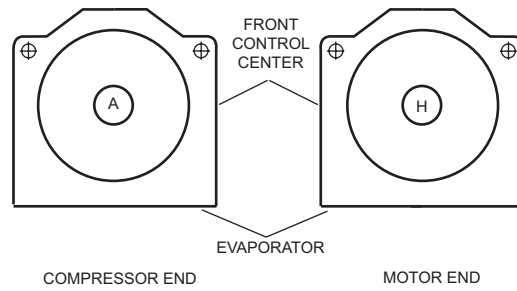

FIG. 3 – 1 PASS

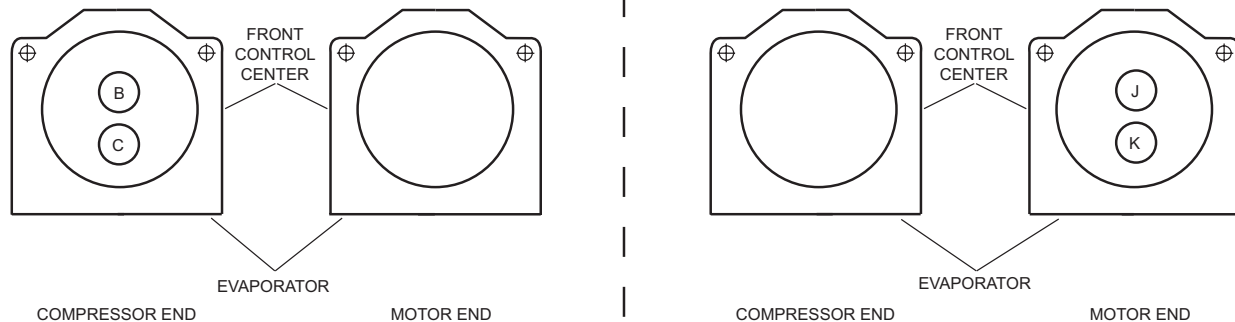

FIG. 4 – 2 PASS

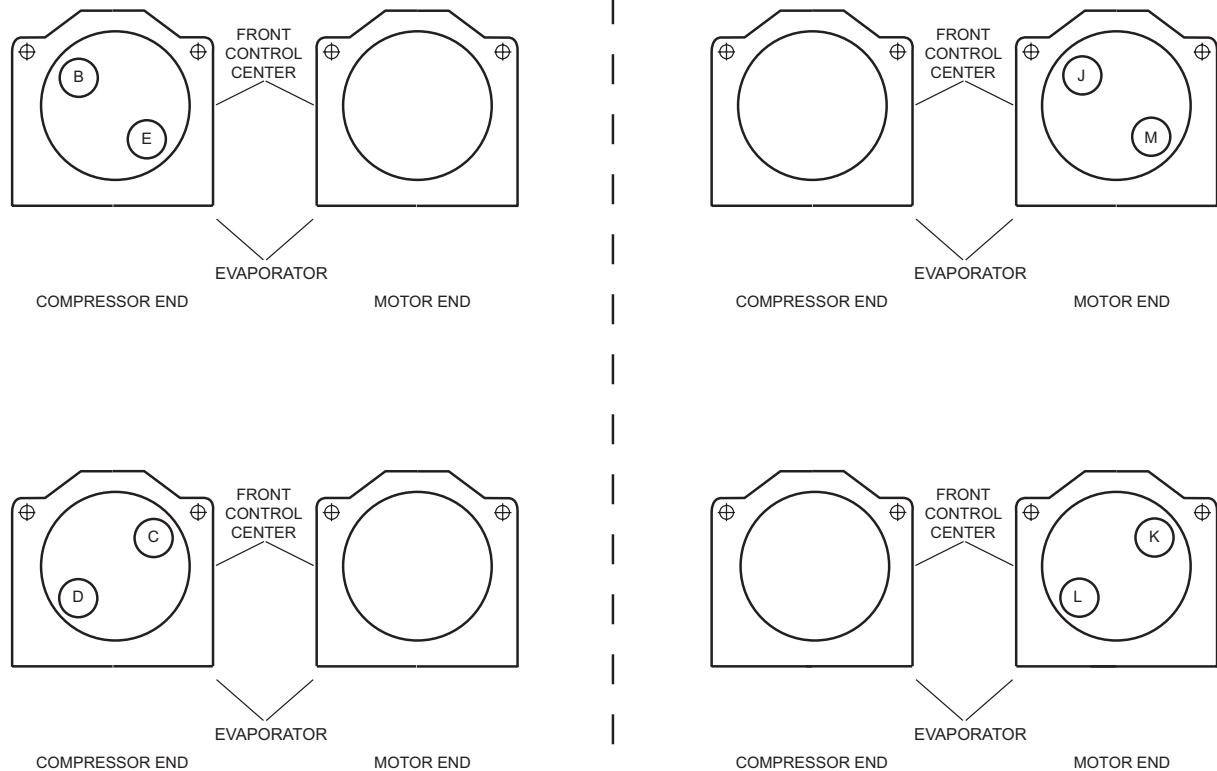

FIG. 5 – 2 PASS

**Notes:**

1. Standard water nozzles are Schedule 40 pipe size, furnished as welding stub-outs with ANSI/AWWA C-606 grooves, allowing the option of welding, flanges, or use of ANSI/AWWA C-606 couplings. Factory installed, Class 150 (ANSI B16.5, round slip-on, forged carbon steel with 1/16" raised face), water flanged nozzles are optional. Companion flanges, nuts, bolts and gaskets are not furnished.
2. One, two and three pass nozzle arrangements are available only in pairs shown. Any pair of evaporator nozzles may be used in combination with any pair of condenser nozzles. Compact water boxes on one heat exchanger may be used with Marine water boxes on the other heat exchanger.
3. Water must enter the water box through the bottom connection to achieve rated performance.
4. Connected piping should allow for removal of compact water boxes for tube access and cleaning.

# Compact Nozzle Arrangements

SHELL CODES	EVAPORATOR COMPACT WATER BOXES																
	1 PASS					2 PASS					3 PASS						
	SIZE	150LB		300LB		SIZE	150LB		300LB		SIZE	150LB		300LB			
IN / OUT		FIG.	IN / OUT	FIG.	IN / OUT		FIG.	IN / OUT	FIG.	IN / OUT		FIG.	IN / OUT	FIG.			
K	16	A/H	3	A/H	3	12	C/B	4	C/B	4	10	G/N	6	G/N	6		
		H/A		H/A			K/J		K/J			P/F		P/F			
N, QQ, QR, QS, Q2, Q3, Q4	18	A/H	7	A/H	3	14	B/C	8	C/B	4	12	F/N	9	G/N	6		
		H/A		H/A			K/J		K/J			N/F		P/F			
							J/K										
							K/J										
QT, QV	20	A/H	7	A/H	3	16	B/C	8	C/B	4	12	F/N	9	G/N	6		
		H/A		H/A			K/J		K/J			N/F		P/F			
							J/K										
							K/J										
R, S, W, X, Z	20	A/H	7	A/H	3	18	B/C	8	E/B	5	14	F/N	9	G/N	6		
		H/A		H/A			M/J		M/J			N/F		P/F			
							J/K										
							K/J										

Note: This table is repeated from the previous page for convenience only.

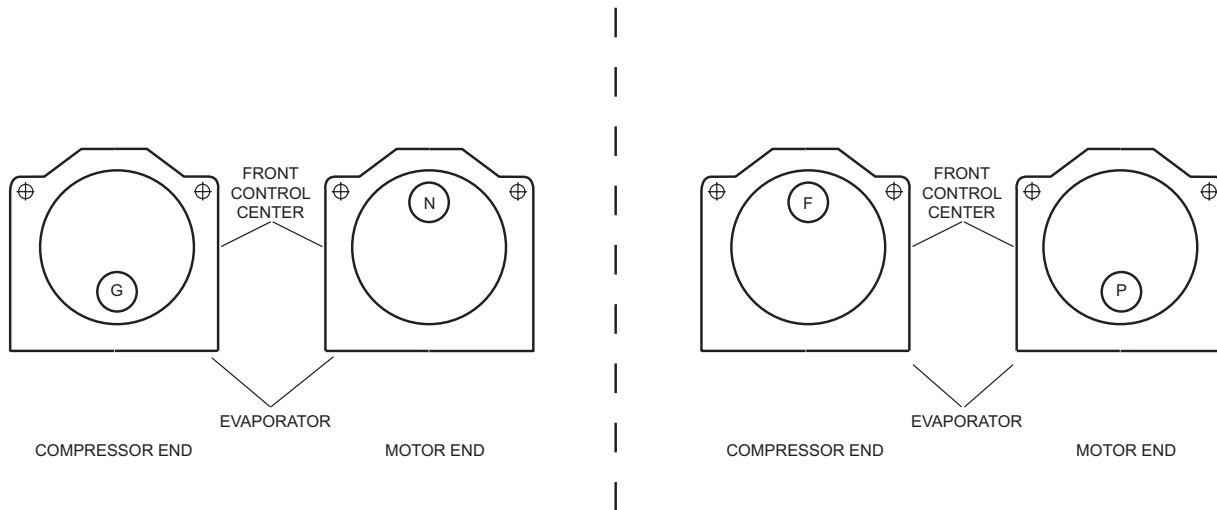

FIG. 6 – 3 PASS

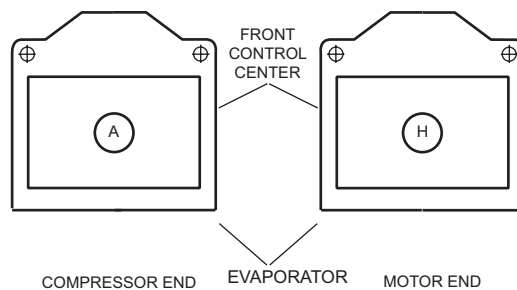

FIG. 7 – 1 PASS

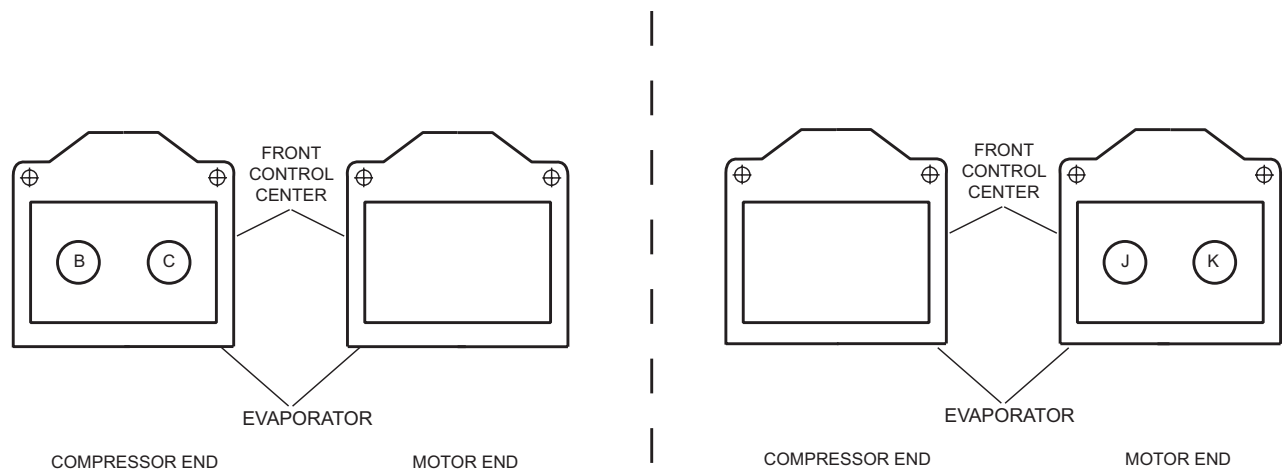

FIG. 8 – 2 PASS

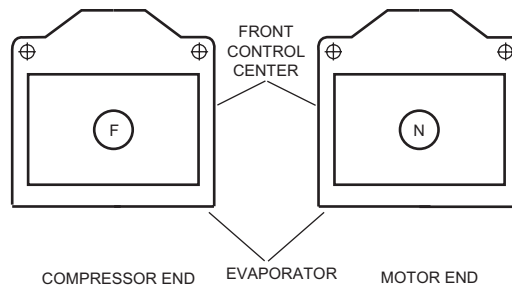

FIG. 9 – 3 PASS

**Notes:**

1. Standard water nozzles are Schedule 40 pipe size, furnished as welding stub-outs with ANSI/AWWA C-606 grooves, allowing the option of welding, flanges, or use of ANSI/AWWA C-606 couplings. Factory installed, Class 150 (ANSI B16.5, round slip-on, forged carbon steel with 1/16" raised face), water flanged nozzles are optional. Companion flanges, nuts, bolts and gaskets are not furnished.
2. One, two and three pass nozzle arrangements are available only in pairs shown. Any pair of evaporator nozzles may be used in combination with any pair of condenser nozzles. Compact water boxes on one heat exchanger may be used with Marine water boxes on the other heat exchanger.
3. Water must enter the water box through the bottom connection to achieve rated performance.
4. Connected piping should allow for removal of compact water boxes for tube access and cleaning.

# Compact Nozzle Arrangements

CONDENSER COMPACT WATER BOXES									
SHELL CODES	1 PASS			2 PASS			3 PASS		
	SIZE	150LB / 300LB		SIZE	150LB / 300LB		SIZE	150LB / 300LB	
		IN / OUT	FIGURE		IN / OUT	FIGURE		IN / OUT	FIGURE
K	16	P / Q OR Q / P	10	10	R / S OR T / U	11	10	V / Y OR X / W	12
N	20			14			10		
Q	20			16			14		
R, S	20			18			14		
W	24			18			16		
X, Z	24			20			16		

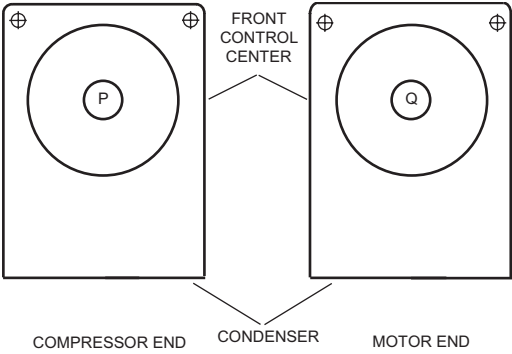

FIG. 10 – 1 PASS

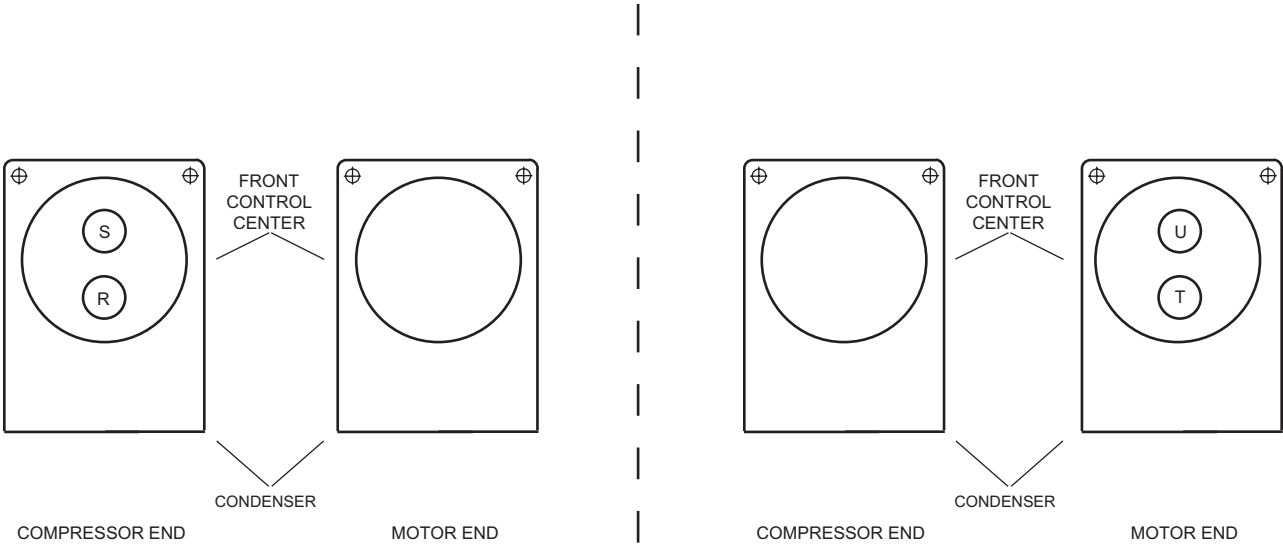
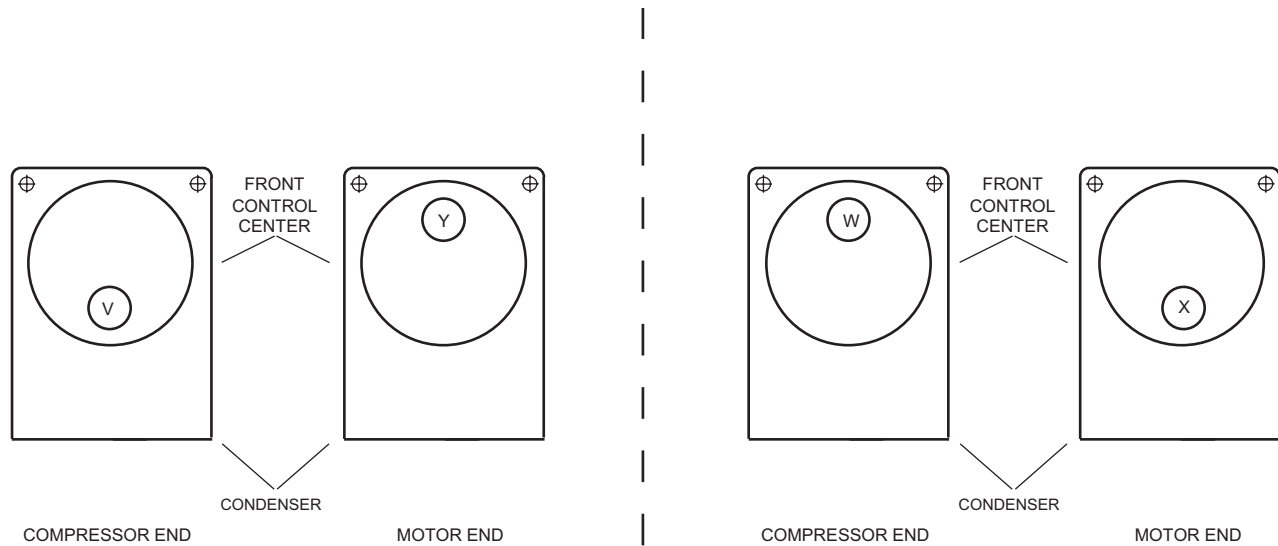

FIG. 11 – 2 PASS





**FIG. 12 – 3 PASS**

**Notes:**

1. Standard water nozzles are Schedule 40 pipe size, furnished as welding stub-outs with ANSI/AWWA C-606 grooves, allowing the option of welding, flanges, or use of ANSI/AWWA C-606 couplings. Factory installed, Class 150 (ANSI B16.5, round slip-on, forged carbon steel with 1/16" raised face), water flanged nozzles are optional. Companion flanges, nuts, bolts and gaskets are not furnished.
2. One, two and three pass nozzle arrangements are available only in pairs shown. Any pair of evaporator nozzles may be used in combination with any pair of condenser nozzles. Compact water boxes on one heat exchanger may be used with Marine water boxes on the other heat exchanger.
3. Water must enter the water box through the bottom connection to achieve rated performance.
4. Connected piping should allow for removal of compact water boxes for tube access and cleaning.

# Marine Nozzle Arrangements

EVAPORATOR MARINE WATER BOXES									
SHELL CODES	1 PASS			2 PASS			3 PASS		
	SIZE	150 LB / 300 LB		SIZE	150 LB / 300 LB		SIZE	150 LB / 300 LB	
		IN / OUT	FIGURE		IN / OUT	FIGURE		IN / OUT	FIGURE
K	16	1 / 6 OR 6 / 1	13	12	2 / 3 OR 7 / 8	14	10	5 / 10 OR 9 / 4	15
N, QQ, QR, QS, Q2, Q3, Q4	18			14			12		
QT, QV	20			16			12		
R, S, W, X, Z	20			18			14		

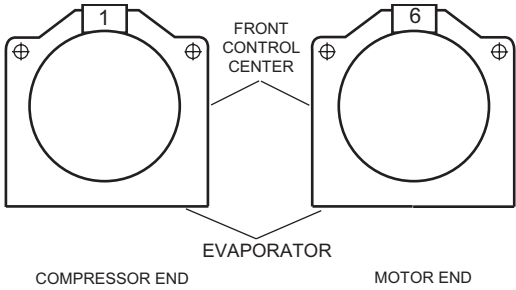

FIG. 13 – 1 PASS

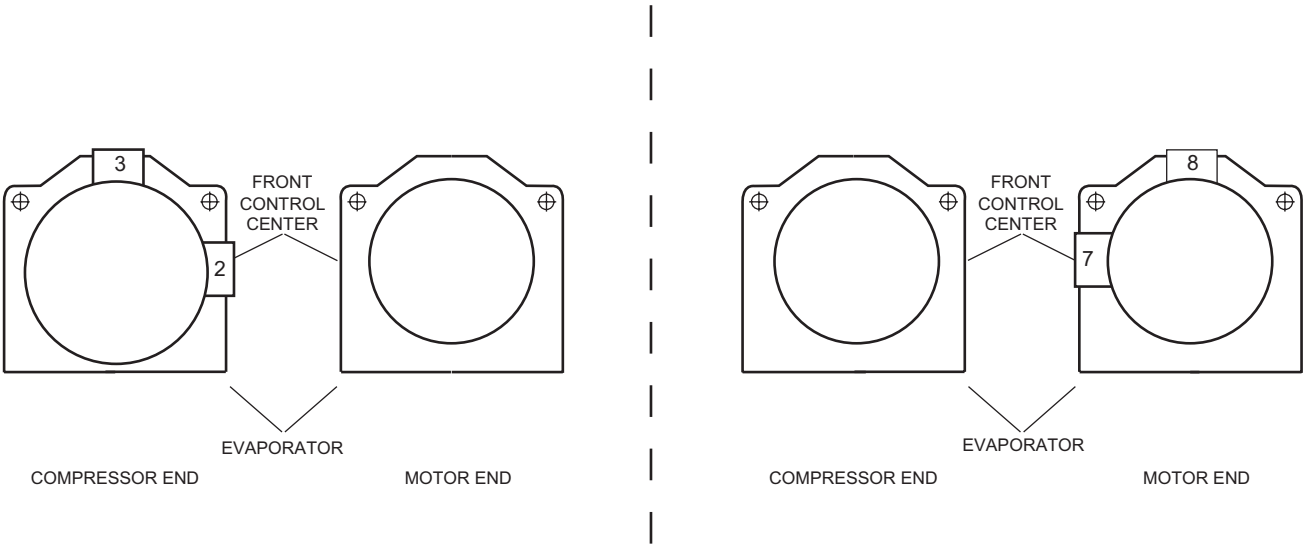

FIG. 14 – 2 PASS

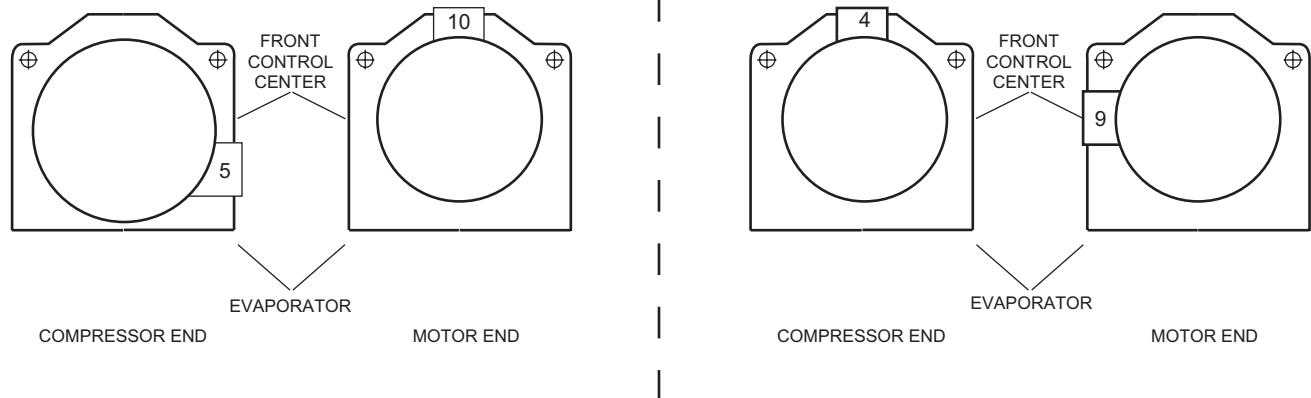

FIG. 15 – 3 PASS

**Notes:**

1. Standard water nozzles are Schedule 40 pipe size, furnished as welding stub-outs with ANSI/AWWA C-606 grooves, allowing the option of welding, flanges, or use of ANSI/AWWA C-606 couplings. Factory installed, Class 150 (ANSI B16.5, round slip-on, forged carbon steel with 1/16" raised face), water flanged nozzles are optional. Companion flanges, nuts, bolts and gaskets are not furnished.
2. One, two and three pass nozzle arrangements are available only in pairs shown. Any pair of evaporator nozzles may be used in combination with any pair of condenser nozzles. Compact water boxes on one heat exchanger may be used with Marine water boxes on the other heat exchanger.
3. Water must enter the water box through the bottom connection to achieve rated performance.
4. Connected piping should allow for removal of compact water boxes for tube access and cleaning.

# Marine Nozzle Arrangements

## CONDENSER MARINE WATER BOXES

SHELL CODES	1 PASS			2 PASS			3 PASS		
	SIZE	150 LB / 300 LB		SIZE	150 LB / 300 LB		SIZE	150 LB / 300 LB	
		IN / OUT	FIGURE		IN / OUT	FIGURE		IN / OUT	FIGURE
K	16	11 / 16 OR 16 / 11	16	10	12 / 13 OR 17 / 18	17	10	15 / 20 OR 19 / 14	18
N	20			14			10		
Q	20			16			14		
R, S	20			18			14		
W	24			18			16		
X, Z	24			20			16		

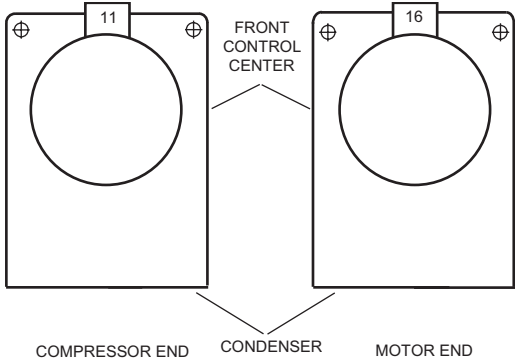

FIG. 16 – 1 PASS

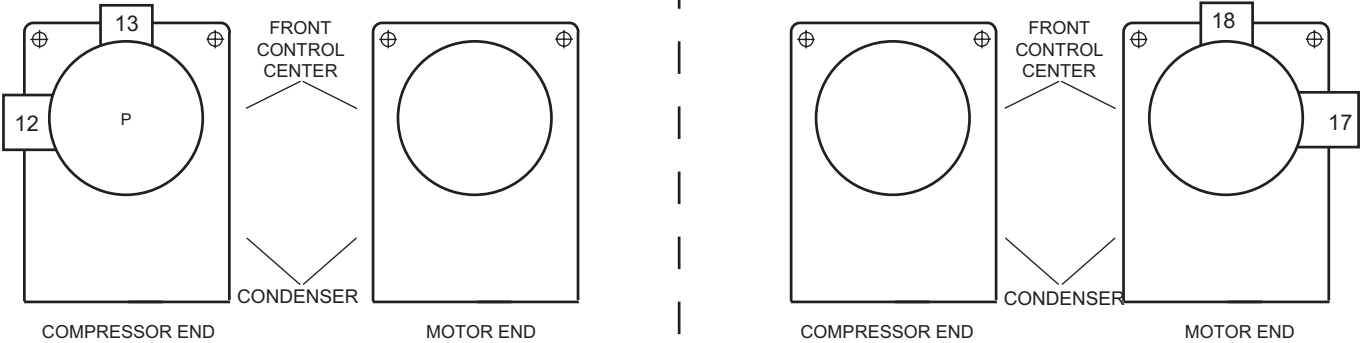

FIG. 17 – 2 PASS

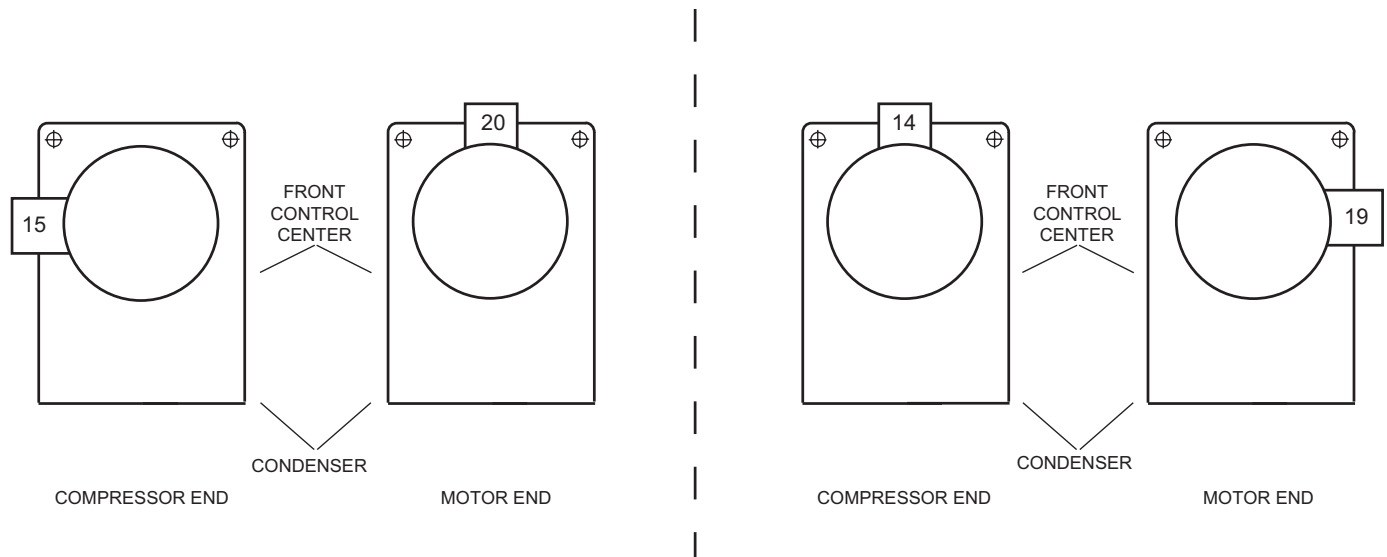

FIG. 18 – 3 PASS

**Notes:**

1. Standard water nozzles are Schedule 40 pipe size, furnished as welding stub-outs with ANSI/AWWA C-606 grooves, allowing the option of welding, flanges, or use of ANSI/AWWA C-606 couplings. Factory installed, Class 150 (ANSI B16.5, round slip-on, forged carbon steel with 1/16" raised face), water flanged nozzles are optional. Companion flanges, nuts, bolts and gaskets are not furnished.
2. One, two and three pass nozzle arrangements are available only in pairs shown. Any pair of evaporator nozzles may be used in combination with any pair of condenser nozzles. Compact water boxes on one heat exchanger may be used with Marine water boxes on the other heat exchanger.
3. Water must enter the water box through the bottom connection to achieve rated performance.
4. Connected piping should allow for removal of compact water boxes for tube access and cleaning.

# Guide Specifications

## GENERAL

Furnish and install where indicated on the drawings \_\_\_\_ YORK model CYK Compound Centrifugal Compressor Liquid Chilling Unit(s). Each unit shall produce a capacity of \_\_\_\_ tons, cooling \_\_\_\_ GPM of \_\_\_\_ from \_\_\_\_ °F to \_\_\_\_ °F when supplied with \_\_\_\_ GPM of condenser water at \_\_\_\_ °F. Total power input (two motors) shall not exceed \_\_\_\_ kW. The evaporator shall be selected for \_\_\_\_ fouling factor and a maximum liquid pressure drop of \_\_\_\_ ft. Water side shall be designed for 150 psig working pressure. The condenser shall be selected for \_\_\_\_ fouling factor and maximum liquid pressure drop of \_\_\_\_ ft. Waterside shall be designed for 150 psig working pressure. Power shall be supplied to the compressor drive motors at \_\_\_\_ volts – 3-phase – (60)(50) Hertz. Auxiliary power to the oil pump motors and controls shall be supplied at \_\_\_\_ volts – 3-phase – (60)(50) Hertz

(or)

Furnish and install where indicated on the drawings \_\_\_\_ YORK model CYK Compound Centrifugal Compressor Heat Pump Unit(s). Each unit shall produce a capacity of \_\_\_\_ tons, heating \_\_\_\_ GMP of \_\_\_\_ from \_\_\_\_ °F to \_\_\_\_ °F when supplied with \_\_\_\_ GPM of evaporator water at \_\_\_\_ °F. Total power input (two motors) shall not exceed \_\_\_\_ kW. The evaporator shall be selected for \_\_\_\_ ft. fouling factor and maximum liquid pressure drop of \_\_\_\_ ft. Waterside shall be designed for 150 psig working pressure. The condenser shall be selected for \_\_\_\_ ft. fouling factor and maximum liquid pressure drop of \_\_\_\_ kPa. Waterside shall be designed for 150 psig working pressure.

(or)

Furnish and install where indicated on the drawings \_\_\_\_ YORK model CYK Compound Centrifugal Compressor Liquid Chilling Unit(s). Each unit shall produce a capacity of \_\_\_\_ kW, cooling \_\_\_\_ L/S of \_\_\_\_ from \_\_\_\_ °C to \_\_\_\_ °C when supplied with \_\_\_\_ L/S of condenser water at \_\_\_\_ °C. Total power input (two motors) shall not exceed \_\_\_\_ kW. The evaporator shall be selected for \_\_\_\_ m<sup>2</sup>°C/W fouling factor and maximum liquid pressure drop of \_\_\_\_ barg. Waterside shall be designed for 10.3 barg working pressure. The condenser shall be selected for \_\_\_\_ m<sup>2</sup>°C/W fouling factor and maximum liquid pressure drop of \_\_\_\_ barg. Waterside shall be designed for 10.3 barg working pressure.

Power shall be supplied to the compressor drive motors at \_\_\_\_ volts – 3-phase – (60)(50) Hertz. Auxiliary power to the oil pump motors and controls shall be supplied at \_\_\_\_ volts - 3-phase – (60)(50) Hertz.

(or)

Furnish and install where indicated on the drawings \_\_\_\_ YORK model CYK Compound Centrifugal Compressor Heat Pump Unit(s). Each unit shall produce a capacity of \_\_\_\_ kW, heating \_\_\_\_ L/S of \_\_\_\_ from \_\_\_\_ °C to \_\_\_\_ °C when supplied with \_\_\_\_ L/S of evaporator water at \_\_\_\_ °C. Total power input (two motors) shall not exceed \_\_\_\_ kW. The evaporator shall be selected for \_\_\_\_ m<sup>2</sup>°C/W fouling factor and maximum liquid pressure drop of \_\_\_\_ kPa. Waterside shall be designed for 10.3 barg working pressure. The condenser shall be selected for \_\_\_\_ m<sup>2</sup>°C/W fouling factor and maximum liquid pressure drop of \_\_\_\_ kPa. Waterside shall be designed for 10.3 barg working pressure.

Each unit shall be completely factory-packaged including evaporator, condenser, sub-cooler, compressors, flash economizer (intercooler), open motors, lubrication system, Control Center, and all interconnecting unit piping and wiring. The economizer is removed for shipment. Flanged joints are provided and all piping is prefabricated. The unit shall be painted prior to shipment. The initial charge of oil and refrigerant shall be supplied, shipped in containers and cylinders for field installation or factory charged in the unit when possible.

## COMPRESSORS

Two centrifugal compressors shall be provided, operating in series and using a common refrigerant circuit on the unit. Check valves will be supplied on the discharge of the low and high stage compressors to control refrigerant flow during single compressor low head operation and two compressor high head operation.

Each compressor shall be a single-stage centrifugal type, powered by an open-drive electric motor. The housing shall be fully accessible with vertical circular joints, with the complete operating assembly removable from the compressor and scroll housing. Compressor castings on the low stage shall be designed for a minimum 235 psig (16.2 barg) working pressure and hydrostatically pressure tested at a minimum of 352 psig (24.3 barg). The high stage shall be designed for 235 or 350 psig (16.2 or 24.1 barg) as applicable, and hydrostatically pressure tested at a minimum of 1.3 times the design pressure. The rotor assembly shall consist of a heat-treated alloy steel drive shaft and impeller shaft with a cast aluminum, fully shrouded impeller. The impeller shall be designed for balanced thrust, dynamically balanced and over-speed tested for smooth, vibration-free operation. Insert-type journal and thrust bearings shall be fabricated of aluminum alloy, precision bored and axially grooved.

Internal single helical gears with crowned teeth shall be designed so that more than one tooth is in contact at all times to provide even load distribution and quiet operation. Each gear shall be individually mounted in its own journal and thrust bearings to isolate it from impeller and motor forces. Shaft seal shall be provided in double bellows, double-seal, cartridge type. A gravity-fed oil reservoir shall be built into the top of the compressor to provide lubrication during coast-down in the event of a power failure.

Capacity control shall be achieved by use of pre-rotation vanes to provide fully modulating control from full load to minimum load. Control shall automatically compensate for adverse operating conditions, such as fouled tubes, and adjust to prior operation after correction of these conditions. The unit shall be capable of continuous, reliable operation with low ECWT at all load conditions as outlined on the equipment schedule. An external electric actuator shall automatically control pre-rotation vane position for each compressor.

### **LUBRICATION SYSTEM**

Lubrication oil shall be force-fed to all compressor bearings, gears, and rotating surfaces by variable speed oil pumps mounted in individual oil reservoirs. Each oil pump shall vary oil flow to its compressor based on operating and stand-by conditions, ensuring adequate lubrication at all times. The oil pump shall operate prior to start-up, during compressor operation and during coast-down.

Dual oil reservoirs, separate from the compressors, shall contain the 2 HP submersible oil pumps and 1500 watt immersion-type oil heaters for each compressor. The oil heaters shall be thermostatically controlled to remove refrigerant from the oil. The oil reservoirs shall be designed and stamped in accordance with ASME pressure vessel code. A non-code reservoir is not acceptable.

Water-cooled oil coolers shall be provided after each oil pump, with factory installed water piping. A thermostatically controlled bypass valve shall maintain the required oil temperature supply from each oil cooler to its compressor.

Oil shall be filtered by externally mounted, 1/2 micron, replaceable cartridge oil filters, equipped with service valves. An automatic oil return system to recover any oil that may have migrated to the evaporator shall be provided. Oil piping shall be completely factory installed and tested.

### **MOTOR DRIVELINE**

Each compressor motor shall be an open drip-proof, squirrel cage, induction type operating at 3570 rpm (2975 rpm for 50 Hz operation).

Each open motor shall be provided with a D-flange, bolted to a cast iron adaptor mounted on the compressor to allow the motor to be rigidly coupled to the compressor to provide factory alignment of motor and compressor shafts. Each motor drive shaft shall be directly connected to its compressor shaft with a flexible disc coupling. The coupling shall have all metal construction with no wearing parts to assure long life, and no lubrication requirements to provide low maintenance. A large steel terminal box with gasketed front access cover shall be provided for field-connected conduit.

### **EVAPORATOR**

Evaporator shall be of the shell-and-tube, flooded type designed for a minimum of 180 psig (12.4 barg) working pressure on the refrigerant side. Shell shall be fabricated from rolled carbon steel plates with fusion welded seams, carbon steel tube sheets, drilled and reamed to accommodate the tubes, and intermediate tube supports spaced no more than four feet apart. The refrigerant side of each shell is designed, tested and stamped in accordance with ASME Boiler and Pressure Vessel Code, Section VIII – Division I.

Heat exchanger tubes shall be high-efficiency, externally and internally enhanced type. Tubes shall utilize the “skip-fin” design, providing a smooth internal and external surface at each intermediate tube support. This provides extra wall thickness and non-work hardened copper at the support location, extending the life of the heat exchangers. If skip-fin tubes are not used, minimum tube wall thickness shall be 0.035” (0.889 mm). Each tube shall be roller expanded into the tube sheets providing a leak-proof seal, and be individually replaceable. Water velocity through the tubes shall not exceed 12 ft./sec. (3.65 m/sec). A liquid level sight glass shall be provided on the side of the shell to aid in determining proper refrigerant charge and to check condition of the refrigerant charge. Aluminum mesh eliminators or baffles shall be located above the tube bundle to prevent liquid refrigerant carryover to the compressor. The evaporator shall have a refrigerant relief device sized to meet the requirements of the ASHRAE 15 Safety Code for Mechanical Refrigeration.

Water boxes shall be removable to permit tube cleaning and replacement. Stub-out water connections having ANSI/AWWA C-606 grooves shall be provided. Water boxes shall be designed for 150 psig (10.3 barg) design working pressure and be tested at 225 psig (15.5 barg). Vent and drain connections with plugs shall be provided on each water box. Low flow protection shall be provided by a thermal-type flow sensor, factory mounted in the water nozzle connection and wired to the unit panel.

# Guide Specifications

## CONDENSER

Condenser shall be of the shell-and-tube type, designed for a minimum of 235 psig (16.2 barg) working pressure on the refrigerant side. Shell shall be fabricated from rolled carbon steel plates with fusion welded seams. Carbon steel tube sheets, drilled and reamed to accommodate the tubes, are welded to the end of each shell. Intermediate tube supports are drilled and reamed to eliminate sharp edges, fabricated from carbon steel plates. The refrigerant side of each shell is designed, tested and stamped in accordance with ASME Boiler and Pressure Vessel Code, Section VIII – Division I.

Heat exchanger tubes shall be high efficiency, externally and internally enhanced type. Tubes shall utilize the “skip-fin” design, providing a smooth internal and external surface at each intermediate tube support. This provides extra wall thickness and non-work hardened copper at the support location, extending the life of the heat exchangers. If skip-fin tubes are not used, minimum tube wall thickness shall be 0.035” (0.889 mm). Each tube shall be roller expanded into the tube sheets providing a leak-proof seal, and be individually replaceable. Water velocity through the tubes shall not exceed 12 ft./sec. (3.65 m/sec.). A liquid level sight glass shall be provided on the side of the shell to aid in determining proper refrigerant charge and to check condition of the refrigerant charge. The condenser shall have dual refrigerant relief devices; each sized to meet the requirements of the ASHRAE 15 Safety Code for Mechanical Refrigeration. Arrangement shall allow either valve to be isolated and replaced without removing the unit refrigerant charge.

Water boxes shall be removable to permit tube cleaning and replacement. Stub-out water connections having ANSI/AWWA C-606 grooves shall be provided. Water boxes shall be designed for 150 psig (1034 barg) design working pressure and be tested at 225 psig (1551 barg). Vent and drain connections with plugs shall be provided on each water box. A thermal-type water flow sensor shall provide low flow protection, factory mounted in the water nozzle connection and wired to the unit control panel.

## FLASH ECONOMIZER (INTERCOOLER)

A single stage flash economizer (intercooler) shall be provided with internally mounted mesh eliminators, liquid spray pipe, an externally mounted (field installed) level transmitter and an external control valve. Economizer shall include eight sight glasses, two above and two below the mesh eliminators, two at the liquid spray pipe and two in liquid line leaving the economizer. A thermometer well shall be furnished for checking liquid temperature. Connections and field installed pressure transmitter and relief valve assemblies shall be provided for field installation.

Support legs of structural steel tubing shall be provided with mounting brackets for optional spring type isolators.

## CONTROL CENTER

**General** – The unit is controlled by a stand-alone QuantumLX microprocessor based control center with Linux operating system (a PLC control center is provided for Dual Evaporator CYK). The unit control panel shall provide control of unit operation and monitoring of unit sensors, actuators, relays and switches. The unit panel shall provide capacity control operation of the two series compressors in response to low entering condenser water and start-up requirements. The panel shall also allow the unit to operate down to 0% evaporator load.

**Control Panel** – The control panel shall include a 10.4” color active matrix display with integral keypad and touch-screen for operator interface. The control panel shall be factory wired, unit mounted, Nema 12, gasketed enclosure. The panel shall be fabricated of 10 gauge steel and include full height front access door. The panel enclosure shall be painted to match the unit color. All controls are arranged for easy access and internally wired to clearly marked terminal strips wiring connections. Wiring shall be color-coded black (power), red (control), light-blue and green (ground), with each wire numerically identified at both ends with wire markers. Wiring enclosed in shielded cables and pre-wired cables shall be color coded per the wiring diagram.

The screen shall detail all operations and parameters, using a graphical representation of the unit and its components. Graphic screens shall provide for:

- a. Unit Overview
- b. Evaporator
- c. Condenser
- d. Low stage compressor
- e. High stage compressor
- f. Motors
- g. Capacity control diagram
- h. Manual/Auto stations for all control outputs

The operator interface shall be programmed to provide display of all major operating parameters in both graphical and list type screen displays. PID control loop set points, and Manual/Auto functions shall be accomplished by the operator interface. Alarm indicators on the graphic display screen shall provide annunciation, and an alarm history screen to which show the most recent alarms, with the time and date of occurrence. Trip status screens shall be provided which show the values of all analog inputs at the time of the last 128 unit safety shutdowns. The time



and date of the shutdown should also be shown. Function Keys shall be provided on the control panel for Unit Start, Stop, Reset and Emergency Stop.

The QuantumLX control system can be accessed remotely by any internet browser, when it is incorporated into an ethernet network. This virtual operator interface allows quick access to the units for full remote management without having to create a separate SCADA or supervisory control.

### CAPACITY CONTROLS SYSTEM

The Capacity Control philosophy of the unit control system shall allow efficient fully automated control, without need for operator intervention. This control system shall monitor and display all safety aspects of the unit and provide alarms and a shutdown if safety limits are exceeded. If operator intervention is required, manual controls shall be provided on the electronic operator interface, for all electric actuators.

The capacity controls algorithm shall automatically seek out the most efficient operation of the unit. The pre-rotation vanes are automated to obey the temperature controller to maintain chilled water production. In cases of low load, the pre-rotation vanes shall automatically throttle and be limited to a minimum anti-surge position. To provide light duty operation, the hot gas recycle valve shall be seamlessly throttled open according to temperature demands. This keeps the centrifugal compressor out of surge and maintains chilled water production.

In cases of high load, which exceeds the motor kilowatt (or current) usage, the capacity controls algorithm shall automatically unload the system to maintain a restriction on power consumption. In the same way, conditions of high discharge pressure or low suction pressure shall override the production of chilled water in the interests of keeping the unit system online.

In cases of light load and low head, the high stage compressor shall be dropped offline, the flash economizer bypassed, and the unit will be run with the low stage compressor like a normal single-compressor unit.

#### Analog Input List:

1. Low Stage Motor Current (% FLA)
2. High Stage Motor Current (% FLA)
3. Subcooler Refrigerant Liquid Level
4. Low Stage Oil Reservoir Oil Level (Brine Units)
5. High Stage Oil Reservoir Oil Level (Brine Units)
6. Evaporator Refrigerant Pressure
7. Condenser Refrigerant Pressure
8. Low Stage Compressor Low Oil Pressure
9. Low Stage Compressor High Oil Pressure

10. High Stage Compressor Low Oil Pressure
11. High Stage Compressor High Oil Pressure
12. Chilled Water-Out Temperature.
13. Chilled Water-In Temperature.
14. Condenser Water In Temperature
15. Condenser Water Out Temperature
16. Evaporator Refrigerant Liquid Temp.
17. Low Stage Compressor Refrigerant Discharge Temperature
18. High Stage Compressor Refrigerant Discharge Temperature
19. Subcooled Refrigerant Liquid Temperature
20. Low Stage Compressor Oil Temperature
21. High Stage Compressor Oil Temperature
22. Low Stage PRV Position
23. High Stage PRV Position
24. Low Stage Compressor high stage thrust Bearing Probe Gap
25. High Stage Compressor thrust bearing Probe gap
26. Flash Economizer Pressure
27. Flash Economizer Refrigerant Liquid Level

#### Digital Inputs:

1. Chilled Water Low Flow Switch
2. Condenser Water Low Flow Switch
3. Low Stage Motor Starter Full Voltage (Run) Auxiliary Contact
4. High Stage Motor Starter Full Voltage (Run) Auxiliary Contact
5. Low Stage Motor Starter Safety Fault Lockout Relay
6. High Stage Motor Starter Safety Fault Lockout Relay
7. Condenser Refrigerant High Pressure Cutout
8. Low Stage Compressor Oil Heater Thermostat
9. High Stage Compressor Oil Heater Thermostat
10. Low Stage PRV Closed Limit Switch
11. High Stage PRV Closed Limit Switch
12. Low Stage Compressor V.S. Oil Pump Drive Faulted Contact
13. High Stage Compressor V.S. Oil Pump Drive Faulted Contact
14. Optional Remote Unit Start Input
15. Emergency Stop

# Guide Specifications

## OptiSound inputs (when available)

1. LS VGD Position
2. LS VGD Stall Sensor
3. HS VGD Position
4. HS VGD Stall Sensor

## Analog Output List

1. Hot Gas Bypass Valve
2. Low Stage Compressor, V.S. Oil Pump Drive Control
3. High Stage Compressor, V.S. Oil Pump Drive Control
4. High Pressure Variable Orifice Valve LCV-114
5. Low Pressure Variable Orifice Valve LCV-116
6. Bypass Level Control valve output LCV-117

## Digital Output List

1. Low Stage Liquid Line Solenoid Valve
2. High Stage Liquid Line Solenoid Valve
3. High Stage Oil Return Solenoid (brine units only)
4. Low Stage Oil Return Solenoid Valve
5. Low Stage Compressor Oil Heater Contactor
6. High Stage Compressor Oil Heater Contactor
7. Low Stage Compressor Motor Start/Stop Control Relay
8. High Stage Compressor Motor Start/Stop Control Relay
9. Low Stage Compressor Oil Pump Start/Stop Relay
10. High Stage Compressor Oil Pump Start/Stop Relay
11. Oil Level Control Pump Start/Stop Relay (brine units only)
12. Open Low Stage PRV
13. Open High Stage PRV
14. Close Low Stage PRV
15. Close High Stage PRV
16. Interstage Sideload Valve

## Optisound Control Outputs (when available)

1. Open Low Stage VGD
2. Close Low Stage VGD
3. Open High Stage VGD
4. Close High Stage VGD

## Security

Security access to prevent unauthorized change of set-points, to allow local or remote control of the unit, and to allow manual operation of the pre-rotation vanes and oil pump shall be provided. Access shall be through ID and password recognition, which is defined by three different levels of user experience: operator, service and programming.

## OVER-CURRENT PROTECTION

The Variable Speed Oil Pump Panel shall include a fused connection through a transformer to provide individual over-current protected power for all controls.

## PLANT MANAGEMENT/CONTROL SYSTEM INTERFACE:

Ethernet is the preferred LAN (Local Area Network) between Local Unit Control Panels. Ethernet allows full management of the QuantumLX system from a central location.

The QuantumLX control system can be accessed remotely by any internet browser, when it is incorporated into an ethernet network. This virtual operator interface allows quick access to the units for full remote management without having to create a separate SCADA or supervisory control.

All required analog and discrete data for communications will be arranged in blocks of 16-bit words. All data is available remotely as read only values. The following write-able control signals are available. Remote Start, Remote Stop, Remote Leaving Chilled Water Setpoint, and Remote Demand Limit Setpoint.

## Available Network Protocols

Any protocol/media requirements not listed below must be called out on the factory order form.

MEDIA	PROTOCOL
CAT-5 TWISTED PAIR	ETHERNET INDUSTRIAL PROTOCOL AND MODBUS TCP <a href="http://WWW.ETHERNET-IP.ORG">WWW.ETHERNET-IP.ORG</a>
RS-232	ALLEN-BRADLEY DF1 FULL DUPLEX
RS-232	MODBUS RTU SLAVE/ASCII SLAVE

Available protocols will be implemented with a Johnson Controls **eLink** module\* or **RedLion Data Station** where applicable:

- Modbus RTU over RS-485\*\*
- BACnet MS/TP\*
- BACnet/IP\*
- Profibus\*\*
- Allen-Bradley DH-485

**Check appropriate protocol and include this document attached to the Factory Order Form.**

All communication interface wiring and hardware, which is required external to the unit control panel, will be supplied and installed by the electrical installation contractor under another contract.

**FACTORY-SUPPLIED COMPRESSOR MOTOR STARTER (2300V & 4160V/3/60Hz or 3300V/3/50Hz)**

The unit manufacturer shall furnish a reduced-voltage, Medium Voltage Solid-State Starter, in accordance with the unit manufacturer's starter specifications. The starter shall be of modular construction with complete access to all parts. The starter shall be tested and the design starting current and overload settings adjusted at the factory. The starter shall provide, through the use of six in-line (not inside the Delta) silicon controlled rectifiers (2 per phase), a smooth acceleration of the motor without current transitions or transients.

The following protective devices and convenience items shall be factory mounted and wired to the starter:

- a. **3-leg Sensing Electronic Overloads** – shuts unit down if current exceeds 105% of FLA to protect the motor windings.
- b. **Phase Rotation Protection Circuit** – denies start-up when detecting incorrect power wiring phase sequence to the starter which could cause reverse motor rotation and damage the equipment.
- c. **Single-Phase Failure Protection Circuit** – ensures against motor burnout by shutting the unit down if power loss occurs in any of the incoming lines during start-up.
- d. **High Temperature Safety Protection System** – temperature activated switches on heat sinks will shut the unit down if the SCR temperature exceeds acceptable limits.
- e. **3-Phase Digital Ammeter And Digital Voltmeter Readout Via Control Center** – easily cross-check design current and voltage limitations against supply characteristics.
- f. Starter mounted load break rated input disconnect switch with interlocked padlockable handle. Positive disconnecting means shall be visible from outside

the enclosure, in operator area. All doors shall be interlocked with the disconnecting means.

- g. **Open/Shorted SCR Protection** – Failed semiconductor devices are automatically detected and reported via the Control Center.
- h. **Power Fault Protection** – momentary power interruption protection detects power interruptions within 3 line cycles and interrupts power to the compressor motor within 1 additional line cycle.
- i. **Electrical Connections** – these tin-plated or copper bus bars provide easy connection to incoming copper power lines.
- k. **Wattmeter** – An instantaneous wattmeter tells the customer how much power the unit is consuming. A kilowatt-hour energy meter is also provided to measure power consumption over a period of time.
- l. **Shutdown History** – The Medium Voltage Solid-State Starter shall provide the system control panel with ten histories of previous unit shutdowns initiated by the starter.

In addition, the Starter shall include as standard, the following convenience items already mounted and wired to the starter at the factory:

- Auxiliary control supply transformer – eliminates the need for running separate 115V - 1 Ø - 50/60 Hz power source wiring to the unit Control Center.

**REMOTE ELECTRO MECHANICAL COMPRESSOR MOTOR STARTER (OPTION)**

A remote electro mechanical starter of the R-1132 type shall be furnished for each compressor motor. The starter shall be furnished in accordance with the unit manufacturer's starter specifications and as specified elsewhere in these specifications.

**PORTABLE REFRIGERANT STORAGE/RECYCLING SYSTEM**

A portable, self-contained refrigerant storage/recycling system shall be provided consisting of a refrigerant compressor with oil separator, storage receiver, water-cooled condenser, filter drier and necessary valves and hoses to remove, replace and distill refrigerant. All necessary controls and safety devices shall be a permanent part of the system.

# SI Metric Conversion

Values provided in this manual are in the English inch-pound (I-P) system.  
The following factors can be used to convert from English to the most common SI Metric values.

MEASUREMENT	MULTIPLY THIS ENGLISH VALUE	BY	TO OBTAIN THIS METRIC VALUE
CAPACITY	TONS REFRIGERANT EFFECT (ton)	3.516	KILOWATTS (kW)
POWER	KILOWATTS (kW)	NO CHANGE	KILOWATTS (kW)
	HORSEPOWER (hp)	0.7457	KILOWATTS (kW)
FLOW RATE	GALLONS / MINUTE (gpm)	0.0631	LITERS / SECOND (L/s)
LENGTH	FEET (ft)	304.8	MILLIMETERS (mm)
	INCHES (in)	25.4	MILLIMETERS (mm)
WEIGHT	POUNDS (lb)	0.4536	KILOGRAMS (kg)
VELOCITY	FEET / SECOND (fps)	0.3048	METERS / SECOND (m/s)
PRESSURE DROP	FEET OF WATER (ft)	2.989	KILOPASCALS (k Pa)
	POUNDS / SQ. INCH (psi)	6.895	KILOPASCALS (k Pa)

## TEMPERATURE

To convert degrees Fahrenheit (°F) to degrees Celsius (°C), subtract 32° and multiply by 5/9 or 0.5556.

To convert a temperature range (i.e., 10°F or 12°F chilled water range) from Fahrenheit to Celsius, multiply by 5/9 or 0.5556.

## EFFICIENCY

In the English I-P system, unit efficiency is measured in kW / ton:

$$\text{kW / ton} = \frac{\text{kW input}}{\text{tons refrigerant effect}}$$

In the SI Metric system, unit efficiency is measured in Coefficient of Performance (COP).

$$\text{COP} = \frac{\text{kW refrigeration effect}}{\text{kW input}}$$

kW / ton and COP are related as follows:

$$\text{kW/ton} = \frac{3.516}{\text{COP}}$$

$$\text{COP} = \frac{3.516}{\text{kW/ton}}$$

## FOULING FACTOR

ENGLISH I-P (ft <sup>2</sup> °F hr/Btu)	EQUIVALENT SI METRIC (m <sup>2</sup> k/kW)
0.0001	.018
0.00025	.044
0.0005	.088
0.00075	.132