



contacto@potabilizar.solutions  
+54 (341) 627 7915

González del Solar 101 Bis - Rosario, Santa Fe. Argentina.

140-200 Tons  
60Hz

 **YORK**<sup>®</sup>  
BY JOHNSON CONTROLS



527 - 1354 kW  
2, 3, and 4 Compressor  
50Hz  
HFC-134a

***Model YCIV Air-Cooled Screw Liquid Chillers  
with Variable Speed Drive  
Style A***

# Table of Contents

---

<i>Introduction</i> .....	3
<i>Unit Overview</i> .....	4
<i>Accessories and Options</i> .....	7
<i>Nomenclature</i> .....	9
<i>Temperatures and Flows</i> .....	10
<i>Water Pressure Drop</i> .....	12
<i>Standard Efficiency Ratings - SI - 400V/50Hz</i> .....	14
<i>High Efficiency Ratings - SI - 400V/50Hz</i> .....	18
<i>Physical Data (SI - Standard Efficiency)</i> .....	22
<i>Physical Data (SI - High Efficiency)</i> .....	24
<i>Dimensions</i> .....	26
<i>Isolator Locations</i> .....	48
<i>Isolator Details</i> .....	52
<i>Electrical Data - 2 Comp Standard Efficiency</i> .....	56
<i>Electrical Data - 2 Comp High Efficiency</i> .....	58
<i>Electrical Data - 3 &amp; 4 Comp Standard Efficiency</i> .....	60
<i>Electrical Data - 3 Comp High Efficiency</i> .....	62
<i>Electrical Notes</i> .....	64
<i>Power Wiring</i> .....	65
<i>Typical Control Wiring - Two Compressor</i> .....	68
<i>Typical Control Wiring - Three Compressor</i> .....	70
<i>Application Data</i> .....	74
<i>Guide Specifications</i> .....	75

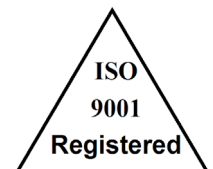

Products are produced at a facility whose quality-management systems are ISO9001 certified.

## YORK YC/IV Air-Cooled Screw Liquid Chillers



**Johnson Controls** has a proud history of innovation in both compressor design and variable-speed-drive (VSD) technology. The Latitude™ series of air-cooled chillers uses the best of modern screw compressor design and manufacturing techniques and combines them with the latest in a long line of chiller variable speed drives. The result is superior control and industry leading efficiency at real world conditions. In addition, by slowing the speed of the chiller to match system requirements at off-design conditions, the chiller sound output is reduced when it is the most sensitive to neighbors – evenings and weekends.

With the introduction of the YC/IV model air-cooled chiller, system designers have the opportunity to design around the traditional benefits of air-cooled chillers and still offer building owners the most up-to-date energy-efficient system design. In the past, the choice to use an air-cooled chiller came with the expectation of compromise, where simplicity of design and maintenance were traded for performance and efficiency. Now, installing the Latitude allows for a combining the best of both worlds can provide a design that truly delivers the lowest total cost of ownership.

## POWER AND ELECTRICAL

- Johnson Controls has over 25 years of experience designing variable speed drives specifically for chiller applications. The result is an extremely reliable air-cooled chiller system that offers industry leading efficiency at real world operating conditions, valve-less compressor loading/unloading, excellent capacity control, high power factor and soft start.
- All controls and motor starting equipment necessary for unit operation shall be factory wired and function tested.
- VSD Power/Control Panel includes main power connection(s), VSD and fan motor contactors, current overloads, and factory wiring. Standard design includes NEMA 3R (IP55) rating, powder painted steel cabinet with hinged, latched, and gasket sealed outer doors equipped with wind struts for safer servicing.
- VSD section of power panel includes a dedicated inverter for each compressor.
- The panel includes a control display access door so display and control features can be accessed without opening main cabinet doors.
- The chillers come standard with single point power connection. In addition, all models are supplied with a factory mounted and wired control transformer that will supply all unit control voltage from the main unit power supply. The transformer utilizes scheduled line voltage on the primary side and provides 115V/1Ø on secondary.
- The standard power panel is equipped with terminal block electrical connections at the point of incoming power. An optional factory mounted circuit breaker is available, at the point of the incoming single point connection, providing the means to disconnect power and short circuit protection. The optional lockable operating handle extends through the power panel door so that power may be disconnected without opening any panel doors.
- Short Circuit Withstand Rating of the chiller electrical enclosure is 30,000 Amps for standard terminal block connection. These ratings are IAW (in accordance with) UL508. (See Accessories and Options section. They can be increased to 65,000 Amps for 380 & 400).
- Compressor motors are powered by a variable speed drive. Therefore, motor current never exceeds the rated load amps (RLA), providing soft starts with no electrical inrush. This eliminates the motor heating and stress always found with conventional motor starters. In addition, by eliminating the heat buildup during starting, the required off-time between starts is reduced to a maximum of two minutes.
- Many utility companies charge an additional fee if power factor is below 0.95. These power factor adjust-

ments/penalties can affect both regular tariff rates, as well as demand charges. All YCIV models have a full load displacement power factor of 95% and maintain this level throughout the operating range. Specifications should always require the installing contractor to be responsible for additional cost to furnish and install power factor correction capacitors if they are not factory mounted and wired.

## SEMI-HERMETIC YORK TWIN SCREW COMPRESSORS

Johnson Controls Engineered Systems' Chiller Design Team has developed a world class compressor with unequaled performance:

- Continuous function, microprocessor controlled, VSD provides valveless, smooth capacity control from 100% down to 10% of chiller capacity for two compressor chillers, 100% down to 7.5% for three compressor chillers, and 100% down to 5% for four compressor chillers. In addition, elimination of the slide valve and associated unloading components resulted in a 50% reduction in compressor moving parts.
- Compressors are direct drive, semi hermetic, rotary twin-screw type, including: muffler, temperature actuated 'off-cycle' heater, rain-tight terminal box, discharge shut-off service valve, and precision machined cast iron housing mounted on elastomeric isolators.
- Reliable suction-gas-cooled, high-efficiency, accessible hermetic compressor motor, full suction gas flow through 0.006" maximum mesh screen, with inherent internal thermal overload protection and external current overload on all three phases.
- Suction gas screen and serviceable, 0.5 micron full flow oil filter within the compressor housing.
- Cast iron compressor housing precisely machined for optimal clearances and superb efficiency. Entire compressor, from suction to discharge has a design working pressure of 24 barg (350 psig) or higher.

## REFRIGERANT CIRCUIT

- Independent refrigerant circuits per compressor, each using copper refrigerant pipe formed on computer-controlled bending machines. This eliminates over 60% of system piping brazed joints as compared to designs that use fittings, resulting in a highly reliable and leak resistant system.
- Liquid line components include: liquid line shut-off valve with charging port, low side pressure relief device, high adsorption removable core filter-drier, sight glass with moisture-indicator, and electronic expansion valve.

- Discharge line provided with manual compressor shutoff service valve (See Options and Accessories for suction line valve). Suction line equipped with closed-cell insulation.
- Insulated external oil separators with no moving parts, 31 barg (450 psig) design working pressure, and UL listing. Refrigerant system differential pressure provides oil flow through service replaceable, 0.5 micron, full flow, cartridge type oil filter internal to compressor.
- Oil cooling is provided by a dedicated air-cooled finned-tube type heat exchanger located in the condenser section of the machine.
- A flash tank is located in each refrigerant circuit to increase the system efficiency. The design working pressure is 31 barg (450 psig).
- Suction lines, oil separators and flash tanks are covered with closed-cell insulation.

## EVAPORATOR

- High efficiency, direct-expansion type cooler with refrigerant in tubes and chilled liquid through the baffled shell. Independent circuits provided for each compressor.
- Design working pressure of the shell waterside is 10.3 barg (150 psig), and 16 barg (235 psig) for the refrigerant side. The evaporator is constructed and tested IAW applicable sections of ASME Pressure Vessel Code, Section VIII, Division (1). Water side exempt per paragraph U-1, ©, (6).
- Removable heads allow access to the internally-enhanced, seamless, copper tubes. Water vent and drain connections are also included.
- The evaporator is equipped with a thermostatically controlled heater for protection to  $-29^{\circ}\text{C}$  ( $-20^{\circ}\text{F}$ ) ambient, and shell is covered with 19mm ( $3/4$ " ), flexible, closed-cell insulation, thermal conductivity of 0.26k maximum. 38mm ( $1-1/2$ " ) foam available as an option.
- Water nozzles have grooves for mechanical (ANSI/AWWA C-606) couplings, and shall be insulated by Contractor after pipe installation. (See the Accessories and Options section for flange options).

## CONDENSER SECTION

- Condenser fans are dynamically and statically balanced, direct-drive, corrosion resistant glass fiber reinforced composite blades molded into a low noise, full airfoil cross section, providing vertical air discharge from extended orifices. Guards of heavy gauge, PVC (polyvinyl chloride) coated.
- Standard and reduced sound level models have condensers fitted with single-speed fans. Low sound models have two-speed fans fitted.

- The fan motors are the high efficiency, direct drive, 6 pole on standard sound models and 8 pole on reduced and low sound models, 3 phase, Class-"F", current overload protected, totally enclosed (TEAO) type with double sealed, permanently lubricated, ball bearings
- Fin and tube condenser coils constructed of seamless, internally enhanced, high condensing coefficient, corrosion resistant copper tubes arranged in staggered rows and mechanically bonded to corrosion resistant alu-minum alloy fins with full height fin collars. Design working pressure is 31 barg (450 psig).

## MICROCOMPUTER CONTROL CENTER

- The microcomputer control center provides automatic control of chiller operation including compressor start/stop and load/unload, anti-recycle timers, condenser fans, evaporator pump, evaporator heater, unit alarm contacts and run signal contacts.
- Chiller automatically resets to normal chiller operation after power failure.
- Unit operating software is stored in non-volatile memory. Field programmable set points are retained in lithium battery backed regulated time clock (RTC) memory for minimum 5 years.
- Alarm contacts are provided to remote alert contacts for any unit or system safety fault.
- Display and Keypad:
  - ◆ The display contains an 80 character liquid crystal display that is both viewable in direct sunlight and has LED backlighting for nighttime viewing. One keypad and display panel is provided with every chiller.
  - ◆ Display and keypad is accessible through display access door without opening main control/electrical cabinet doors.
  - ◆ Display provides unit setpoints, status, electrical data, temperature data, pressures, safety lockouts and diagnostics without the use of a coded display.
  - ◆ The display provides descriptions in English (or available language options), numeric data in English (or Metric) units.
  - ◆ Sealed keypad shall include unit On/Off switch.
- Programmable Setpoints (within Manufacturer limits): display language; leaving chilled liquid temperature: setpoint, control range; local or remote control; units of measure; compressor lead/lag; and maximum chilled water setpoint reset temperature range.
- Display Data: Chiller liquid return and leaving temperatures, ambient, lead compressor identification, clock and schedule, (variable) out of range, remote input indication, chilled liquid reset setpoint, and history

## Unit Overview - continued

data for last ten shutdown faults. Also provided are messages for compressor suction, discharge, and oil pressures and temperatures, suction and discharge superheats, percent of full-load, operating hours, starts, and anti-recycle timer status. Status Messages for manual override, unit switch off, compressor run, run permissive, remote controlled shut down, no cooling load, daily/holiday shut down, anti-recycle timer.

- During extreme or unusual conditions (i.e. blocked condenser coils, ambient above scheduled maximum, etc.) the chiller control system will avoid safety shutdown by varying the chiller controls and cooling load output to stay online and avoid safety limits being reached. This allows maximum possible cooling capacity until the unusual condition is cleared and avoids costly shutdowns. The system monitors the following parameters and maintains the maximum cooling output possible without shutdown of the equipment: motor current, suction pressure and discharge pressure.
- System Safeties are provided for individual compressor systems to perform auto-reset shut down (manual reset required after the third trip in 90 minutes). Safeties include: high discharge pressure or temperature, low suction pressure, high/low motor current, high motor temperature, high pressure switch, high/low differential oil pressure, high oil temperature, low suction superheat, critical sensor malfunction, low or high current, phase loss/single phase power, overload of motor windings, and low voltage.
- Unit Safeties are provided for the chiller to perform auto-reset shut down for the following conditions: high or low ambient, low leaving chilled liquid temperature, under voltage, and flow switch operation.
- After assembly, an operational test is performed with water flowing through the cooler to ensure each circuit operates correctly.
- Unit panels, structural elements, control boxes and heavy gauge structural base shall be constructed of galvanized steel. Unit panels, control boxes and structural base are finished with a baked on powder paint. All painted surfaces shall be coated with baked on powder paint which, when subject to ASTM B117, 1,000 hour, 5% salt spray test, yields minimum ASTM 1654 rating of "6".
- Design is IAW applicable sections of ASME Pressure Vessel Code, NFPA 70 (National Electrical Code), U.L. and cU.L. standards and ASHRAE/ANSI-15 Safety Code for Mechanical Refrigeration.
- Design is IAW ASHRAE 90.1 Energy Standard for Building except Low-Rise Residential Buildings and AHRI 70 Sound Rating of Large Outdoor Refrigeration and Air Conditioning Equipment.
- YCIV chillers are designed within EN ISO 9001 and built within an EN ISO 9002 accredited manufacturing organization.
- All exposed power wiring routed through liquid-tight, UV-stabilized, non-metallic conduit.
- When required, 50 Hz chillers have the option available to conform to the following European Directives:
  - Machinery directive (2006/42/EC)
  - Low Voltage Directive (2006/95/EC)
  - EMC Directive (2004/108/EC)
  - Pressure Equipment Directive (97/23/EC)
  - Safety Code for Mechanical Refrigeration (EN378-2 (2008))

### COMPLETE FACTORY PACKAGE

- These air-cooled chillers are shipped as a complete factory package. Each unit is completely assembled with all interconnecting refrigerant piping and internal wiring, ready for field installation:
- Each compressor is installed on its own independent refrigerant circuit, which is factory pressure tested, evacuated, then fully charged with HFC-134a refrigerant and oil.

# Accessories and Options

## SOUND REDUCTION OPTIONS

The standard chiller has fans that operate at normal speed, no compressor enclosure, and is typically used in non-sensitive sound areas such as industrial areas or locations with loud traffic background noise. One or more of the following sound reduction options may be employed by the system designer as normally generated machine noise is considered in the overall project design.

**ULTRA QUIET FANS** – With this option, the basic chiller is equipped with specially designed fans and motors to provide lower sound levels and retain appropriate airflow. The result is reduced fan generated noise with minimal effect on the chiller capacity or efficiency. **(Factory-mounted)**

**TWO-SPEED FANS** – With this option, the basic chiller is equipped with fans designed with two operating speeds. At high ambient conditions the fans operate at the normal speed with sound levels equivalent to Ultra Quiet Fans. As the ambient temperature falls the fans automatically reduce to slow speed reducing sound levels. If very low sound is required at all ambient conditions normal fan speed can be inhibited. **(Factory-mounted)**

**REDUCED SOUND OPTION** – With this option the chiller is equipped with an unlined compressor enclosure. This option is typically used for daytime operation where background noise is lower than normal city traffic etc. **(Factory-mounted)**

**LOW SOUND OPTION** – This option is only available with the selection of Ultra Quiet Fans or Two-Speed Fans. The chiller is equipped with an acoustically lined compressor enclosure. This option is typically for locations near residential areas, hotels, or hospitals etc where background noise is limited. When paired with the Two-Speed Fan option the unit can operate at normal speed during the day, when background noise levels are noticeable, and at low speed in the evening and at night when background levels are lower. **(Factory-mounted)**

**SilentNight™** - Standard variable speed compressors result in a chiller system that has lower part load sound values than conventional air-cooled chillers. Over 99% of chiller operating hours occur when building loads are less than design and/or ambient temperatures are less than design. As a result, all YCIV model chillers will operate with less than full load sound output nearly all the time – this is especially important on evenings and weekends when neighbors are home the most. Due to time of day based sound regulations it may be desirable to force the chiller to a lower sound level on demand. The **SilentNight™** control option provides a control input to limit sound output of the chiller based on time of day. This feature is programmable at the chiller panel or can be controlled remotely via signal (4-20mA or 0-10 VDC) from a BAS system.

**HIGH STATIC FANS** - (400V/50Hz) Condenser fans with higher power motors suitable for high external static pres-

sure, up to 100Pa (0.4 in. water), across condenser coils. Select this option if additional air-flow resistance may be present due to flow restrictions such as field installed ducts, filters, sound-enclosures etc. **(Factory-mounted)**

**HIGH AIRFLOW FANS** - (400V/50Hz) Condenser fans with airfoil type blades and high power motors providing extra airflow across coils. In some chiller configurations, this option can provide an increase in chiller capacity. Please contact your local JCI sales representative for more information. **(Factory-mounted)**

## CONDENSER COIL PROTECTION

Standard condenser coil construction materials include aluminum fins, copper tubes, and galvanized tube supports for generally good corrosion resistance. However, these materials are not adequate for all environments. The system designer can take steps to inhibit coil corrosion in harsh applications and enhance equipment life by choosing from these options based on project design parameters and related environmental factors. **(Factory-mounted)**

- **PRE-COATED FIN CONDENSER COILS** – The air-cooled condenser coils are constructed of epoxy-coated aluminum fins. This can provide corrosion resistance comparable to copper-fin coils in typical seashore locations. Either these or the post coated coils (below), are recommended for units being installed at the seashore or where salt spray may hit the unit.
- **POST-COATED EPOXY DIPPED CONDENSER COILS** – The unit is built with dipped-cured epoxy condenser coils. This is another choice for seashore and other corrosive applications (with the exception of strong alkalis, oxidizers and wet bromine, chlorine and fluorine in concentrations greater than 100 ppm).
- **COPPER FIN CONDENSER COILS** – The unit constructed with copper tube condenser coils, which have copper fins. (This is not recommended for units in areas where they may be exposed to acid rain.)

## PROTECTIVE CHILLER PANELS:

- **Wire Panels (full unit)** – UV stabilized black polyvinyl chloride coated, heavy gauge, welded wire mesh guards mounted on the exterior of the unit. Protects condenser coil faces and prevents unauthorized access to refrigerant components (compressors, pipes, cooler, etc.), yet provides free air flow. This can cut installation cost by eliminating the need for separate, expensive fencing. **(Factory-mounted)**
- **Louvered Panels (condenser coils only)** – Louvered panels, painted the same color as the unit, are mounted over the exterior condenser coil faces on the

# Accessories and Options

sides of the unit to visually screen and protect coils. **(Factory-mounted)**

- **Louvered Panels (full unit)** – Louvered panels, painted the same color as the unit, enclose the unit to protect condenser coils from incidental damage, visually screen internal components, and prevent unauthorized access to internal components. **(Factory-mounted)**
- **Louvered (Condensers)/Wire Panels (Mechanical)** – Louvered panels, painted the same color as the unit, are mounted on external condenser coil faces. Heavy gauge, welded wire-mesh, coated to resist corrosion, around base of machine to restrict unauthorized access. **(Factory-mounted)**

## EVAPORATOR OPTIONS:

- **38mm (1-1/2") Insulation** – Double thickness insulation provided. **(Factory-mounted)**
- **Raised Face Flange Accessory** for cooler nozzles:
  - ◆ 10.3 barg (150 psig), welded flanges (field kit, matching pipe flange by contractor).
  - ◆ 10.3 barg (150 psig) companion weld flanges. (field kit).
  - ◆ 150 psig (10.3 barg), ANSI/AWWA C-606 COUPLINGS (field kit, matching pipe flange by contractor).
- **Opposite Handed Evaporator Water Connections** for ease of installation. Standard water connections are on the left-hand side of the unit, when viewed from the control panel end.

## GENERAL OPTIONS:

**FLOW SWITCH ACCESSORY** - Vapor proof SPDT, NEMA 3R switch, 10.3 barg (150 psig) DWP, -7°C to 121°C (20°F to 250°F) with 1" NPT (IPS) connection for upright mounting in horizontal pipe (This flow switch or equivalent must be furnished with each unit). **(Field-mounted)**.

**DIFFERENTIAL PRESSURE SWITCH** - Alternative to the paddle-type flow switch. 0.2-3 barg (3-45 psig) range with 1/4" NPTE pressure connections. **(Field-mounted)**

**BUILDING AUTOMATION SYSTEM INTERFACE** - Chiller to accept 4 to 20mA or 0 to 10 VDC input to reset the leaving chilled liquid temperature. **(Factory-mounted)**

**MULTI-UNIT SEQUENCE CONTROL** - Separate sequencing control center provided to permitting control of up to eight chillers in parallel based on mixed liquid temperature (interconnecting wiring by others). **(Field-mounted)**

**SERVICE ISOLATION VALVE** – Service suction isolation valve added to unit for each refrigerant circuit. **(Factory-mounted)**

**CHICAGO CODE RELIEF VALVE** - Special relief valves per Chicago code. **(Factory-mounted)**

**PRESSURE RELIEF (CE/PED) SERVICE VALVE KIT** - Each relief valve is mounted on a sealable ball valve to aid maintenance. **(Factory-mounted)**

**CIRCUIT BREAKER** – Power panel will come equipped with a factory mounted circuit breaker at the point of incoming single or multi-point connections that provides the following:

- A means to disconnect power mounted on chiller.
- Circuit breaker(s) sized to provide the motor branch circuit protection, short circuit protection and ground fault protection for the motor branch-circuit conductors, the motor control apparatus and the motors. (Chiller mounted circuit breaker option sized for branch circuit protection eliminates the need to provide a separate 'line of sight' disconnect and separate branch circuit protection device.)
- A lockable operating handle that extends through power panel door. This allows power to be disconnected without opening any panel doors.
- A Short Circuit Withstand Rating of 65,000 amps when the chiller electrical enclosure when using circuit breaker option is 380, 400, & 460. Rated IAW UL508.

## VIBRATION ISOLATION:

- **Elastomeric Isolation** – This option is recommended for normal installations. It provides very good performance in most applications for the least cost. **(Field-mounted)**
- **25mm (1") Spring Isolators** – Spring and cage type isolators for mounting under the unit base rails. They are level adjustable. 1" nominal deflection may vary slightly by application. **(Field-mounted)**
- **51mm (2") Seismic Spring Isolators** – Restrained Spring-Flex Mounting isolators incorporate a rugged welded steel housing with vertical and horizontal limit stops. Housings designed to withstand a minimum 1.0g accelerated force in all directions up to 51mm (2"). The deflection may vary slightly by application. They are level adjustable. **(Field-mounted)**



**NOMENCLATURE**

The Model Number denotes the following characteristics of the unit:

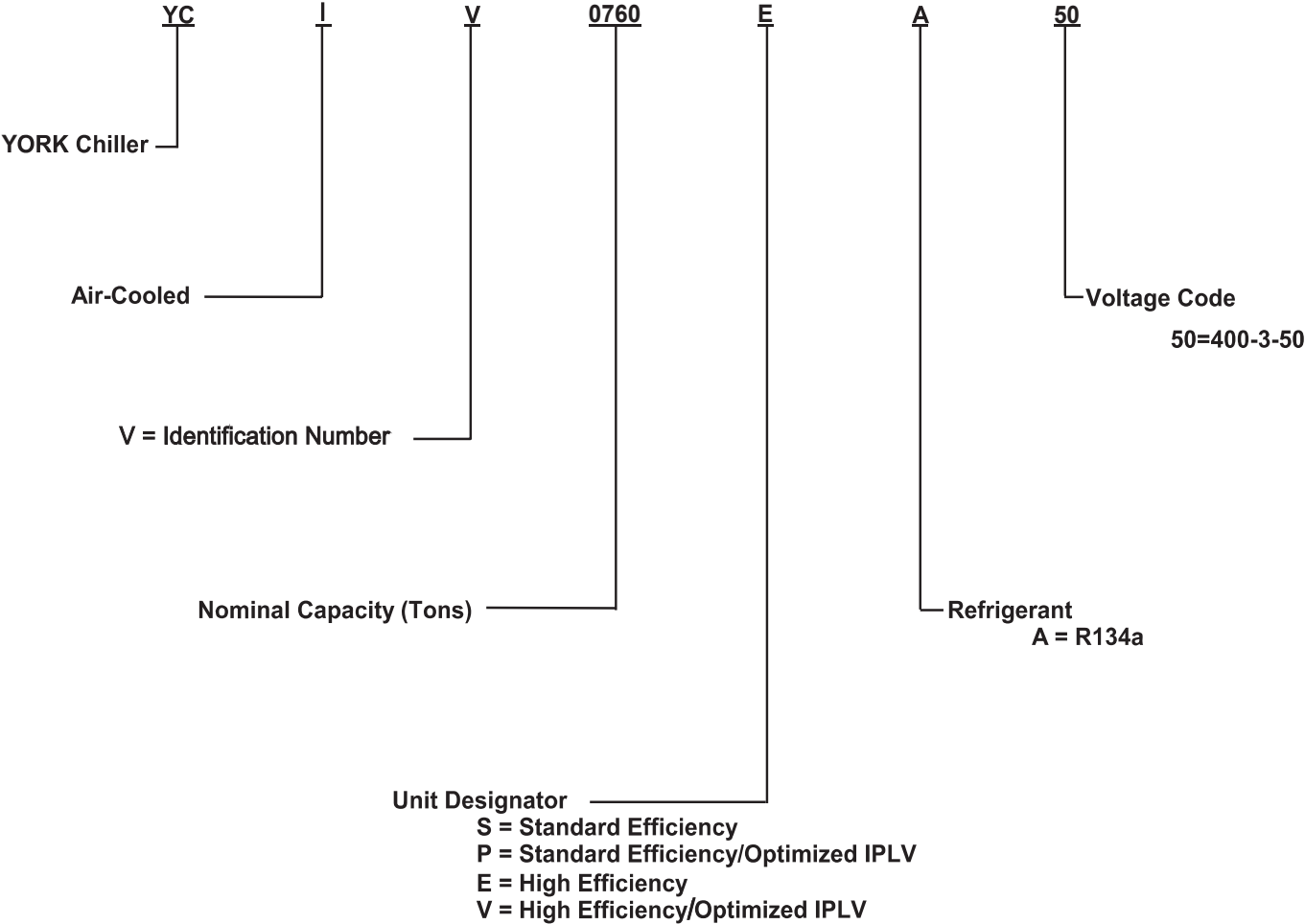

## TEMPERATURE AND FLOWS (SI Units)

MODEL NUMBER YCIV	LEAVING WATER TEMPERATURE (°C)		COOLER <sup>3</sup> FLOW (L/S)		AIR ON CONDENSER (°C)	
	MIN. <sup>1</sup>	MAX. <sup>2</sup>	MIN.	MAX.	MIN.	MAX.
50 HZ						
0600(S/P)	4.4	15.6	8.8	42.6	-17.8	51.7
0590(E/V)	4.4	15.6	10.1	47.3	-17.8	51.7
0650(S/P)	4.4	15.6	10.1	47.3	-17.8	51.7
0630(E/V)	4.4	15.6	10.1	47.3	-17.8	51.7
0720(S/P/I)	4.4	15.6	10.1	47.3	-17.8	51.7
0700(E/V)	4.4	15.6	10.1	47.3	-17.8	51.7
0760(E/V)	4.4	15.6	11.4	47.3	-17.8	51.7
0770(S/P)	4.4	15.6	11.4	50.5	-17.8	51.7
0800(E/V)	4.4	15.6	11.4	47.3	-17.8	51.7
0840(S/P)	4.4	15.6	11.4	50.5	-17.8	51.7
0830(E/V)	4.4	15.6	11.4	47.3	-17.8	51.7

**NOTES:**

1. For leaving brine temperature below 4.4°C (40°F), contact your nearest Johnson Controls office for application requirements.
2. For leaving water temperature higher than 15.6°C (60°F), contact the nearest Johnson Controls office for application guidelines.
3. The evaporator is protected against freezing to -28.8°C (-20°F) with an electric heater as standard.

## TEMPERATURE AND FLOWS (SI Units)

MODEL NUMBER YCIV	LEAVING WATER TEMPERATURE (°C)		COOLER <sup>3</sup> FLOW (L/S)		AIR ON CONDENSER (°C)	
	MIN. <sup>1</sup>	MAX. <sup>2</sup>	MIN.	MAX.	MIN.	MAX
50 HZ						
0920(S/P)	4.4	15.6	11.4	50.5	-17.8	51.7
0930(E/V)	4.4	15.6	10.1	47.3	-17.8	51.7
1000(S/P)	4.4	15.6	11.4	50.5	-17.8	51.7
1050(E/V)	4.4	15.6	11.4	50.5	-17.8	51.7
1070(S/P)	4.4	15.6	15.8	75.7	-17.8	51.7
1120(E/V)	4.4	15.6	15.8	75.7	-17.8	51.7
1180(S/P)	4.4	15.6	18.9	75.7	-17.8	51.7
1220(E/V)	4.4	15.6	18.9	75.7	-17.8	51.7
1340(S/P)	4.4	15.6	18.9	75.7	-17.8	51.7
1380(E/V)	4.4	15.6	18.9	75.7	-17.8	51.7
1500(S/P)	4.4	15.6	18.9	75.7	-17.8	51.7
1649(P)	4.4	15.6	25.2	88.2	-17.8	51.7

**NOTES:**

1. For leaving brine temperature below 4.4°C (40°F), contact your nearest Johnson Controls office for application requirements.
2. For leaving water temperature higher than 15.6°C (60°F), contact the nearest Johnson Controls office for application guidelines.
3. The evaporator is protected against freezing to -28.8°C (-20°F) with an electric heater as standard.

## SI UNITS

Pressure Drop Through Two Circuit YCIV Evaporators

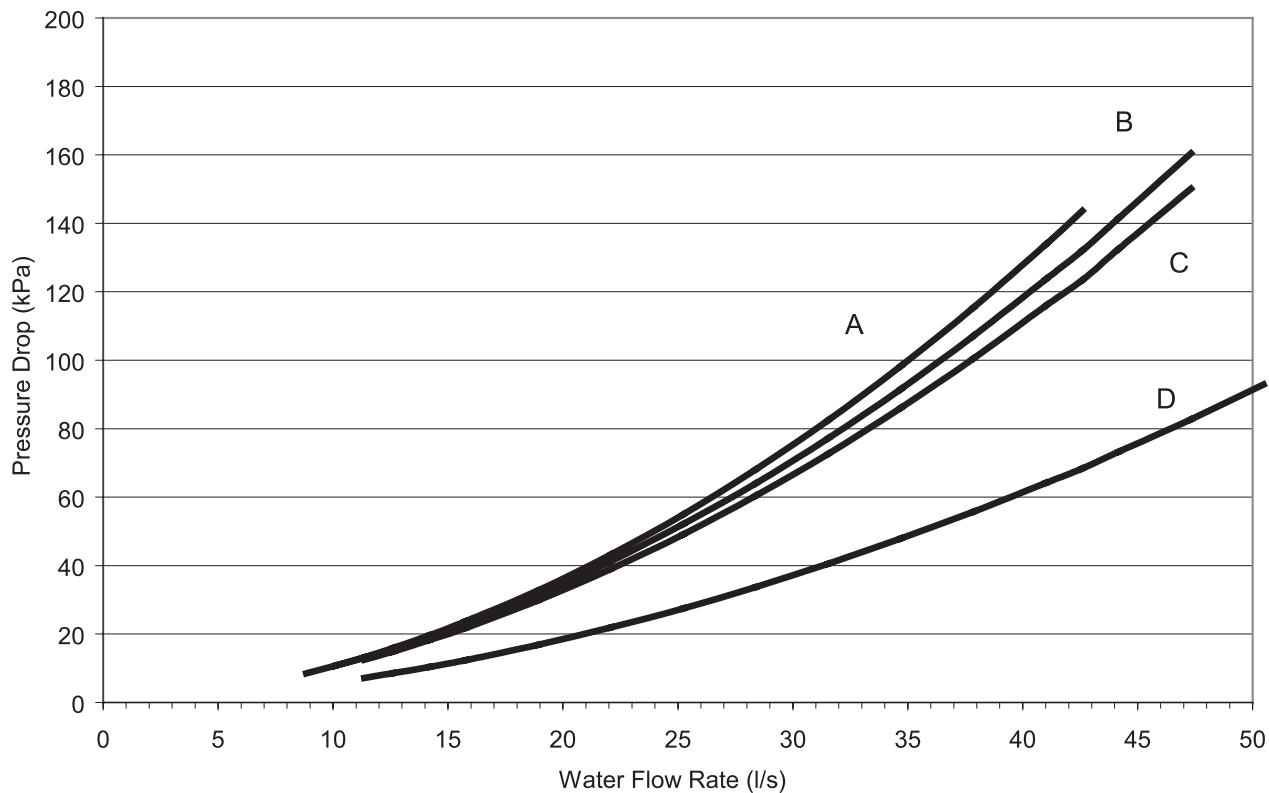

COOLER	MODEL NUMBER YCIV
	50Hz
A	0600(S/P)
B	0590(E/V)
	0630(E/V), 0650(S/P)
C	0700(E/V), 0720(S/P)
	0760(E/V)
	0800(E/V)
D	0830(E/V)
	0770(S/P)
	0840(S/P)
	0920(S/P), 0930(E/V)
	1000(S/P)

## SI UNITS

### Pressure Drop Through Three and Four Circuit YCIV Evaporators

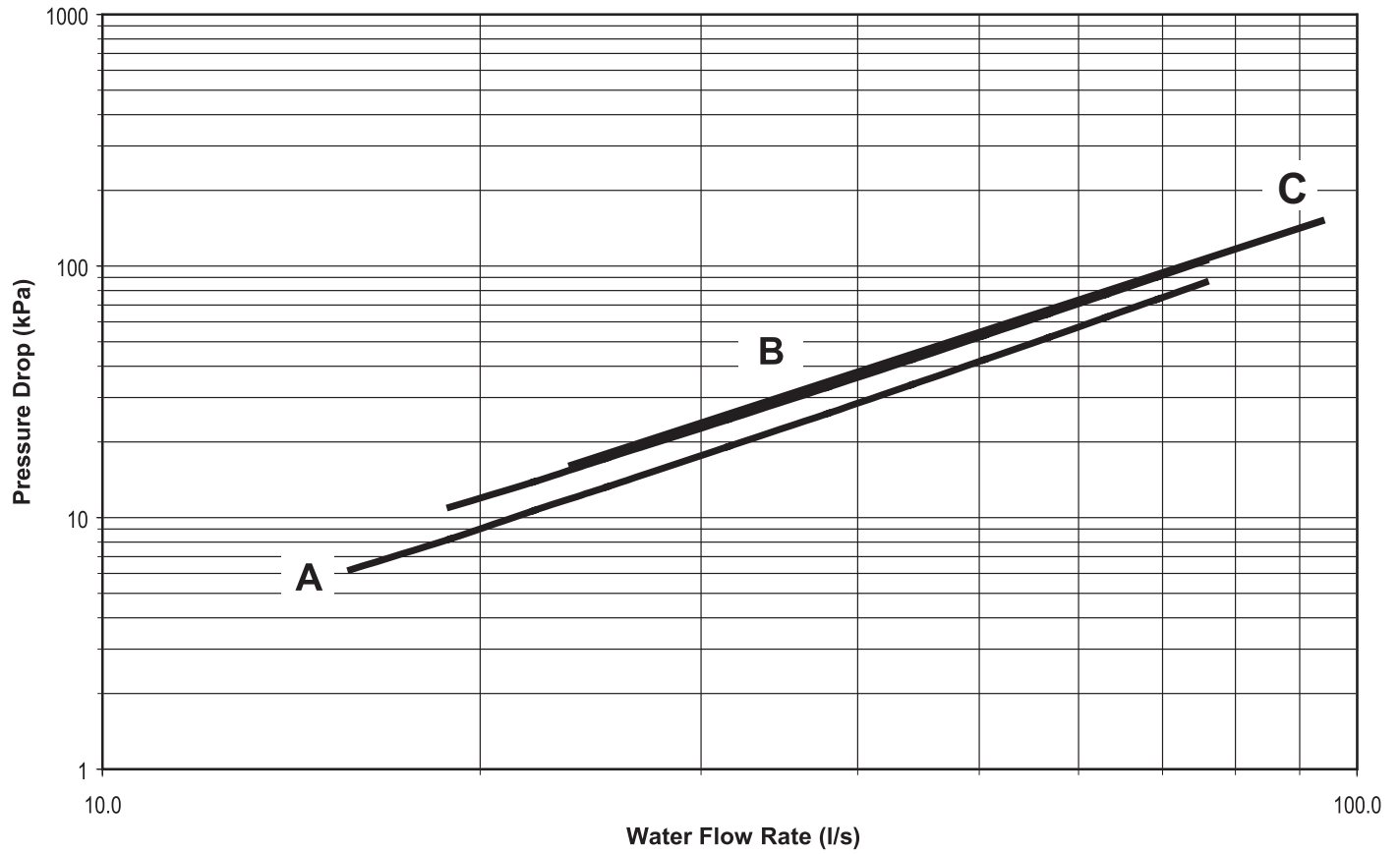

EVAP	YCIV MODELS
	50Hz
A	1050(E/V)
	1070(S/P)
	1120(E/V)
B	1180(S/P)
	1220(E/V)
	1340(S/P)
	1380(E/V)
	1500(S/P)
C	1649(P)

# Standard Efficiency Ratings - SI - 400V/50Hz

FORM 201.23-EG2 (713)

## MODEL: YCIV0600S/P

AIR TEMPERATURE ON - CONDENSER (°C)																		
LCWT (°C)	25.0			30.0			35.0			40.0			45.0			46.0		
	KW	KW	COP	KW	KW	COP	KW	KW	COP	KW	KW	COP	KW	KW	COP	KW	KW	COP
5.0	528.8	133.1	3.6	520.9	152.2	3.2	511.8	172.8	2.8	497.4	196.1	2.4	462.2	214.6	2.0	455.0	218.5	2.0
6.0	543.2	134.0	3.7	535.0	152.9	3.2	525.5	173.7	2.8	509.5	196.7	2.4	473.3	215.3	2.1	465.8	219.2	2.0
7.0	557.9	134.9	3.8	549.4	153.8	3.3	539.5	174.5	2.9	521.7	197.3	2.5	484.5	216.0	2.1	476.8	219.9	2.0
8.0	572.9	135.8	3.8	564.1	154.6	3.4	553.7	175.4	2.9	533.9	197.9	2.5	495.5	216.9	2.2	487.9	220.6	2.1
9.0	588.0	136.8	3.9	578.9	155.6	3.4	568.2	176.3	3.0	546.3	198.5	2.6	507.2	217.5	2.2	499.2	221.3	2.1
10.0	603.4	137.9	4.0	594.1	156.6	3.5	583.0	177.3	3.1	558.9	199.1	2.6	519.0	218.1	2.2	510.8	222.0	2.2
11.0	619.1	139.1	4.1	609.5	157.6	3.6	598.0	178.4	3.1	571.6	199.7	2.7	531.0	218.7	2.3	522.6	222.6	2.2
12.0	635.0	140.3	4.1	625.1	158.7	3.6	613.2	179.4	3.2	584.5	200.3	2.7	542.9	219.3	2.3	532.1	221.1	2.3
13.0	651.2	141.6	4.2	641.0	159.8	3.7	628.7	180.5	3.2	597.5	201.0	2.8	555.1	219.9	2.4	537.5	215.9	2.3

## MODEL: YCIV0650S/P

AIR TEMPERATURE ON - CONDENSER (°C)																		
LCWT (°C)	25.0			30.0			35.0			40.0			45.0			46.0		
	KW	KW	COP	KW	KW	COP	KW	KW	COP	KW	KW	COP	KW	KW	COP	KW	KW	COP
5.0	587.3	146.6	3.7	576.4	167.9	3.2	563.2	190.9	2.8	536.0	208.9	2.4	491.4	218.9	2.1	462.3	206.9	2.1
6.0	603.7	147.6	3.8	592.6	168.9	3.3	579.1	192.0	2.8	550.1	209.5	2.5	496.5	214.8	2.2	467.9	203.3	2.2
7.0	620.4	148.6	3.8	609.2	169.9	3.3	595.2	193.1	2.9	563.9	210.0	2.5	502.4	210.9	2.2	474.0	199.7	2.2
8.0	637.4	149.7	3.9	626.0	170.9	3.4	611.2	193.9	3.0	577.7	210.4	2.6	508.8	207.2	2.3	479.4	195.7	2.3
9.0	654.7	150.8	4.0	643.0	171.9	3.5	626.8	194.3	3.0	591.8	210.7	2.6	514.8	203.2	2.4	484.4	191.6	2.4
10.0	672.0	152.0	4.1	660.4	173.1	3.5	642.6	194.8	3.1	605.9	211.0	2.7	520.5	199.0	2.5	488.9	187.6	2.4
11.0	689.4	153.4	4.1	677.8	174.4	3.6	658.6	195.3	3.2	620.3	211.4	2.8	525.7	194.9	2.5	493.2	183.6	2.5
12.0	707.1	154.9	4.2	695.4	175.6	3.7	674.7	195.8	3.2	634.8	211.7	2.8	530.6	190.8	2.6	497.4	179.6	2.6
13.0	725.1	156.4	4.3	713.3	177.0	3.7	691.0	196.4	3.3	649.5	212.0	2.9	534.7	186.7	2.7	501.5	175.7	2.7

## MODEL: YCIV0720S/P

AIR TEMPERATURE ON - CONDENSER (°C)																		
LCWT (°C)	25.0			30.0			35.0			40.0			45.0			46.0		
	KW	KW	COP	KW	KW	COP	KW	KW	COP	KW	KW	COP	KW	KW	COP	KW	KW	COP
5.0	639.4	158.1	3.7	628.8	180.6	3.2	616.7	205.2	2.8	594.6	230.0	2.4	551.9	245.6	2.1	543.3	248.7	2.1
6.0	657.2	159.2	3.8	646.3	181.6	3.3	633.7	206.2	2.9	608.9	230.4	2.5	564.8	246.2	2.2	556.2	249.2	2.1
7.0	675.3	160.5	3.9	664.0	182.7	3.4	651.0	207.3	2.9	623.5	230.8	2.5	578.2	246.7	2.2	569.2	249.7	2.2
8.0	693.7	161.8	3.9	682.0	183.9	3.4	668.4	208.5	3.0	638.4	231.1	2.6	591.9	247.1	2.3	582.6	250.2	2.2
9.0	712.5	163.2	4.0	700.4	185.1	3.5	686.2	209.8	3.1	653.5	231.5	2.7	605.8	247.4	2.3	596.2	250.6	2.2
10.0	731.6	164.7	4.1	719.0	186.5	3.6	704.3	211.0	3.1	668.7	231.8	2.7	619.9	247.8	2.4	605.6	247.6	2.3
11.0	751.0	166.3	4.1	738.0	187.9	3.6	722.8	212.3	3.2	683.9	232.2	2.8	634.3	248.1	2.4	610.8	241.4	2.4
12.0	770.7	168.0	4.2	757.3	189.4	3.7	741.6	213.7	3.2	699.5	232.6	2.8	648.9	248.4	2.5	616.4	235.6	2.5
13.0	790.7	169.9	4.3	776.9	191.0	3.8	760.7	215.3	3.3	715.3	233.0	2.9	660.2	246.2	2.5	621.8	229.7	2.5

**NOTES:**

1. kW<sub>o</sub> = Unit kW Cooling Capacity Output
2. kW<sub>i</sub> = Compressor kW Input
3. COP = Coefficient of Performance (includes condenser fan power)
4. LCWT = Leaving Chilled Water Temperature
5. Ratings based on 0.168 l/s cooler water per ton, and 0.018 (m<sup>2</sup> - °C)/kW
6. AHRI 550/590 does not provide certification for 50Hz ratings. The unique use of the YCIV variable speed drive allows compressor operation at the output speed regardless of the input power frequency. This allows for common unit/heat exchanger configurations between 60Hz and 50Hz with closely matching capacity.

**MODEL: YCIV0770S/P**

AIR TEMPERATURE ON - CONDENSER (°C)																		
LCWT (°C)	25.0			30.0			35.0			40.0			45.0			46.0		
	KW	KW	COP	KW	KW	COP	KW	KW	COP	KW	KW	COP	KW	KW	COP	KW	KW	COP
5.0	689.5	170.6	3.7	676.6	196.8	3.2	662.1	226.0	2.8	629.2	248.2	2.4	564.5	248.2	2.1	530.0	233.3	2.1
6.0	709.0	171.7	3.8	695.5	197.6	3.3	680.0	226.6	2.8	644.2	248.0	2.5	569.7	242.9	2.2	536.2	228.8	2.2
7.0	728.8	173.0	3.9	714.8	198.5	3.4	697.4	226.7	2.9	659.6	247.8	2.5	576.2	238.0	2.3	542.0	223.9	2.3
8.0	749.1	174.4	4.0	734.4	199.5	3.4	715.2	226.8	3.0	675.3	247.4	2.6	582.3	232.8	2.4	547.6	219.0	2.3
9.0	769.7	176.1	4.0	754.5	200.6	3.5	733.3	227.1	3.0	691.2	247.0	2.6	588.4	227.7	2.4	553.1	214.3	2.4
10.0	790.7	178.1	4.1	774.9	202.0	3.6	751.7	227.4	3.1	707.2	246.7	2.7	594.3	222.6	2.5	558.1	209.8	2.5
11.0	812.1	180.2	4.2	795.7	203.6	3.6	770.3	227.8	3.2	723.6	246.3	2.8	599.9	217.8	2.6	563.0	205.4	2.6
12.0	834.0	182.6	4.2	816.9	205.3	3.7	789.3	228.2	3.2	740.2	245.9	2.8	605.2	213.2	2.7	567.7	200.9	2.6
13.0	856.2	185.1	4.3	838.5	207.2	3.8	808.6	228.9	3.3	757.1	245.6	2.9	610.1	208.7	2.7	572.5	196.6	2.7

**MODEL: YCIV0840S/P**

AIR TEMPERATURE ON - CONDENSER (°C)																		
LCWT (°C)	25.0			30.0			35.0			40.0			45.0			46.0		
	KW	KW	COP	KW	KW	COP	KW	KW	COP	KW	KW	COP	KW	KW	COP	KW	KW	COP
5.0	748.4	182.6	3.8	735.1	208.5	3.3	720.1	236.9	2.8	690.4	263.0	2.5	640.3	275.7	2.2	630.5	278.0	2.1
6.0	769.6	184.0	3.8	755.7	209.7	3.3	739.9	238.2	2.9	707.1	263.1	2.5	655.5	276.0	2.2	645.2	278.3	2.2
7.0	791.1	185.5	3.9	776.7	211.0	3.4	760.1	239.6	3.0	724.0	263.2	2.6	671.0	276.2	2.3	660.4	278.6	2.2
8.0	813.1	187.2	4.0	798.1	212.4	3.5	780.9	241.0	3.0	741.2	263.3	2.7	686.8	276.3	2.3	676.0	278.7	2.3
9.0	835.5	189.0	4.1	819.9	214.1	3.6	802.0	242.4	3.1	758.8	263.3	2.7	702.9	276.4	2.4	690.9	278.2	2.3
10.0	858.4	190.9	4.1	842.2	215.7	3.6	823.6	244.0	3.2	776.3	263.4	2.8	719.2	276.5	2.5	697.1	272.2	2.4
11.0	881.7	193.0	4.2	864.9	217.5	3.7	845.6	245.6	3.2	794.4	263.5	2.8	735.9	276.4	2.5	703.5	266.0	2.5
12.0	905.3	195.2	4.3	888.1	219.4	3.8	867.9	247.4	3.3	812.7	263.6	2.9	752.5	276.2	2.6	710.1	259.7	2.6
13.0	929.1	197.6	4.3	911.5	221.4	3.8	890.8	249.3	3.4	831.3	263.7	3.0	759.3	269.5	2.7	716.0	253.0	2.7

**MODEL: YCIV0920S/P**

AIR TEMPERATURE ON - CONDENSER (°C)																		
LCWT (°C)	25.0			30.0			35.0			40.0			45.0			46.0		
	KW	KW	COP	KW	KW	COP	KW	KW	COP	KW	KW	COP	KW	KW	COP	KW	KW	COP
5.0	821.2	201.2	3.7	807.2	229.1	3.3	791.2	259.7	2.8	762.5	289.7	2.5	716.5	309.3	2.2	707.4	313.0	2.1
6.0	844.2	202.8	3.8	829.7	230.5	3.3	812.9	261.2	2.9	781.4	290.3	2.5	733.9	310.0	2.2	724.3	313.8	2.2
7.0	867.7	204.5	3.9	852.5	232.1	3.4	834.9	262.9	3.0	800.6	290.9	2.6	751.6	310.7	2.3	740.0	313.3	2.2
8.0	891.5	206.4	4.0	875.8	233.9	3.5	857.5	264.6	3.0	820.1	291.5	2.7	769.8	311.3	2.3	747.8	307.2	2.3
9.0	915.8	208.4	4.0	899.5	235.7	3.5	880.5	266.3	3.1	839.9	292.1	2.7	788.2	311.9	2.4	755.3	300.7	2.4
10.0	940.5	210.4	4.1	923.7	237.6	3.6	904.0	268.2	3.2	859.8	292.8	2.8	804.7	311.1	2.4	762.4	293.8	2.4
11.0	965.7	212.7	4.2	948.2	239.6	3.7	927.8	270.0	3.2	880.3	293.4	2.8	812.6	304.1	2.5	769.0	286.5	2.5
12.0	991.2	215.1	4.2	973.3	241.7	3.7	952.1	272.1	3.3	901.1	294.0	2.9	820.0	296.6	2.6	775.2	279.1	2.6
13.0	1017.2	217.0	4.3	998.6	243.9	3.8	976.9	274.2	3.3	922.2	294.7	2.9	826.9	289.0	2.7	780.9	272.0	2.7

**NOTES:**

1. kW<sub>o</sub> = Unit kW Cooling Capacity Output
2. kW<sub>i</sub> = Compressor kW Input
3. COP = Coefficient of Performance (includes condenser fan power)
4. LCWT = Leaving Chilled Water Temperature
5. Ratings based on 0.168 l/s cooler water per ton, and 0.018 (m<sup>2</sup> - °C)/kW
6. AHRI 550/590 does not provide certification for 50Hz ratings. The unique use of the YCIV variable speed drive allows compressor operation at the output speed regardless of the input power frequency. This allows for common unit/heat exchanger configurations between 60Hz and 50Hz with closely matching capacity.

# Standard Efficiency Ratings - SI - 400V/50Hz

## MODEL: YCIV1000S/P

AIR TEMPERATURE ON - CONDENSER (°C)																		
LCWT (°C)	25.0			30.0			35.0			40.0			45.0			46.0		
	KW	KW	COP	KW	KW	COP	KW	KW	COP	KW	KW	COP	KW	KW	COP	KW	KW	COP
5.0	894.3	219.6	3.7	879.6	249.4	3.3	862.6	282.2	2.9	834.9	316.1	2.5	793.0	342.4	2.2	784.6	347.5	2.1
6.0	919.1	221.4	3.8	903.8	251.2	3.3	886.1	284.0	2.9	856.0	317.2	2.5	812.6	343.6	2.2	803.8	348.8	2.2
7.0	944.5	223.3	3.9	928.6	253.0	3.4	909.9	286.0	3.0	877.4	318.3	2.6	832.6	344.8	2.3	821.7	348.8	2.2
8.0	970.2	225.4	4.0	953.7	255.0	3.5	934.4	287.9	3.0	899.1	319.4	2.7	853.0	345.9	2.3	829.3	341.0	2.3
9.0	996.3	227.5	4.0	979.4	257.0	3.5	959.2	290.0	3.1	921.3	320.5	2.7	873.9	347.1	2.4	837.1	333.1	2.4
10.0	1023.0	229.8	4.1	1005.4	259.2	3.6	984.6	292.1	3.2	943.6	321.7	2.8	892.6	346.7	2.4	844.9	325.2	2.5
11.0	1050.0	232.2	4.2	1031.8	261.5	3.7	1010.4	294.2	3.2	966.5	322.9	2.8	900.9	338.2	2.5	852.6	317.4	2.5
12.0	1077.5	234.8	4.2	1058.8	263.8	3.7	1036.6	296.5	3.3	989.7	324.0	2.9	909.1	329.9	2.6	860.1	309.8	2.6
13.0	1105.6	236.2	4.3	1086.0	266.3	3.8	1063.2	298.9	3.3	1013.3	325.3	2.9	917.1	321.7	2.7	867.0	302.7	2.7

## MODEL: YCIV1070S/P

AIR TEMPERATURE ON - CONDENSER (°C)																		
LCWT (°C)	25.0			30.0			35.0			40.0			45.0			46.0		
	KW	KW	COP	KW	KW	COP	KW	KW	COP	KW	KW	COP	KW	KW	COP	KW	KW	COP
5.0	949.5	231.0	3.8	932.1	265.4	3.2	911.8	303.1	2.8	873.5	336.2	2.4	791.6	344.8	2.2	743.1	325.2	2.1
6.0	976.3	232.5	3.8	958.3	266.7	3.3	937.2	304.4	2.9	895.5	336.6	2.5	799.7	338.3	2.2	752.1	319.4	2.2
7.0	1003.6	234.1	3.9	985.0	268.0	3.4	962.8	305.6	2.9	917.2	336.9	2.6	808.0	331.5	2.3	761.5	313.7	2.3
8.0	1031.4	235.8	4.0	1012.3	269.5	3.5	988.1	306.3	3.0	939.4	337.1	2.6	818.0	325.4	2.4	770.3	307.5	2.3
9.0	1059.7	237.8	4.1	1040.1	271.0	3.6	1013.9	307.0	3.1	962.0	337.2	2.7	827.4	319.0	2.4	778.7	301.3	2.4
10.0	1088.5	240.0	4.2	1068.4	272.8	3.6	1040.2	307.9	3.2	985.0	337.2	2.7	836.6	312.5	2.5	786.4	295.0	2.5
11.0	1117.8	242.5	4.2	1097.2	274.7	3.7	1066.9	308.9	3.2	1008.2	337.3	2.8	845.3	306.1	2.6	793.4	288.8	2.6
12.0	1147.6	245.2	4.3	1126.5	276.9	3.8	1094.0	309.9	3.3	1031.7	337.4	2.9	853.4	299.8	2.7	800.2	282.7	2.6
13.0	1177.9	248.0	4.4	1156.3	279.2	3.8	1121.6	311.1	3.4	1055.6	337.6	2.9	860.6	293.5	2.7	806.8	276.6	2.7

## MODEL: YCIV1180S/P

AIR TEMPERATURE ON - CONDENSER (°C)																		
LCWT (°C)	25.0			30.0			35.0			40.0			45.0			46.0		
	KW	KW	COP	KW	KW	COP	KW	KW	COP	KW	KW	COP	KW	KW	COP	KW	KW	COP
5.0	1055.2	254.8	3.8	1036.1	294.0	3.3	1014.7	337.5	2.8	970.6	374.3	2.4	868.6	373.3	2.2	815.4	351.0	2.2
6.0	1084.9	256.5	3.9	1064.9	295.1	3.3	1042.0	338.3	2.9	993.7	374.1	2.5	876.5	365.3	2.3	824.1	343.8	2.2
7.0	1115.3	258.3	4.0	1094.4	296.3	3.4	1069.2	338.7	3.0	1017.4	373.7	2.6	885.7	357.6	2.3	833.7	336.9	2.3
8.0	1146.3	260.4	4.0	1124.5	297.7	3.5	1097.1	339.2	3.0	1041.6	373.3	2.6	896.0	350.3	2.4	842.6	329.7	2.4
9.0	1178.0	262.8	4.1	1155.3	299.4	3.6	1125.4	339.9	3.1	1066.2	372.7	2.7	905.5	342.6	2.5	851.2	322.6	2.5
10.0	1210.2	265.6	4.2	1186.6	301.4	3.7	1154.3	340.6	3.2	1091.1	372.1	2.8	914.9	335.1	2.6	859.2	315.8	2.5
11.0	1243.0	268.7	4.3	1218.5	303.7	3.7	1183.7	341.5	3.2	1116.3	371.6	2.8	923.7	327.9	2.6	866.8	309.2	2.6
12.0	1276.6	272.1	4.3	1251.1	306.1	3.8	1213.7	342.5	3.3	1142.1	371.0	2.9	932.2	321.0	2.7	874.2	302.6	2.7
13.0	1310.6	276.0	4.4	1284.3	308.9	3.9	1244.1	343.9	3.4	1168.3	370.5	3.0	939.9	314.3	2.8	881.4	296.1	2.8

**NOTES:**

1. kW<sub>o</sub> = Unit kW Cooling Capacity Output
2. kW<sub>i</sub> = Compressor kW Input
3. COP = Coefficient of Performance (includes condenser fan power)
4. LCWT = Leaving Chilled Water Temperature
5. Ratings based on 0.168 l/s cooler water per ton, and 0.018 (m<sup>2</sup> - °C)/kW
6. AHRI 550/590 does not provide certification for 50Hz ratings. The unique use of the YCIV variable speed drive allows compressor operation at the output speed regardless of the input power frequency. This allows for common unit/heat exchanger configurations between 60Hz and 50Hz with closely matching capacity.



<b>MODEL: YCIV1340S/P</b>																		
AIR TEMPERATURE ON - CONDENSER (°C)																		
LCWT (°C)	25.0			30.0			35.0			40.0			45.0			46.0		
	KW	KW	COP	KW	KW	COP	KW	KW	COP	KW	KW	COP	KW	KW	COP	KW	KW	COP
5.0	1191.3	291.5	3.7	1170.8	332.4	3.3	1147.5	377.2	2.8	1105.5	420.8	2.5	1034.8	446.6	2.2	1020.8	451.5	2.1
6.0	1224.9	293.8	3.8	1203.5	334.4	3.3	1179.0	379.3	2.9	1132.5	421.5	2.5	1059.6	447.6	2.2	1045.0	452.5	2.2
7.0	1259.1	296.1	3.9	1236.8	336.6	3.4	1211.2	381.6	3.0	1160.1	422.2	2.6	1085.1	448.4	2.3	1070.0	453.4	2.2
8.0	1294.0	298.7	4.0	1270.8	339.0	3.5	1244.0	384.0	3.0	1188.2	422.8	2.6	1111.1	449.1	2.3	1085.2	447.5	2.3
9.0	1329.5	301.6	4.1	1305.4	341.5	3.5	1277.5	386.5	3.1	1216.8	423.4	2.7	1137.4	449.8	2.4	1096.7	438.8	2.4
10.0	1365.7	304.6	4.1	1340.7	344.2	3.6	1311.7	389.0	3.2	1245.7	424.1	2.8	1164.1	450.5	2.4	1107.5	429.2	2.4
11.0	1402.6	307.8	4.2	1376.7	347.0	3.7	1346.7	391.6	3.2	1275.0	424.8	2.8	1179.6	443.2	2.5	1117.3	418.9	2.5
12.0	1439.8	311.3	4.3	1413.4	350.1	3.8	1382.2	394.5	3.3	1305.0	425.4	2.9	1190.8	432.9	2.6	1126.4	408.1	2.6
13.0	1477.6	314.5	4.3	1450.3	353.2	3.8	1418.5	397.5	3.3	1335.5	426.1	3.0	1201.1	421.9	2.7	1134.7	397.2	2.7

<b>MODEL: YCIV1500S/P</b>																		
AIR TEMPERATURE ON - CONDENSER (°C)																		
LCWT (°C)	25.0			30.0			35.0			40.0			45.0			46.0		
	KW	KW	COP	KW	KW	COP	KW	KW	COP	KW	KW	COP	KW	KW	COP	KW	KW	COP
5.0	1337.3	328.4	3.7	1315.3	373.1	3.3	1289.8	422.2	2.9	1249.5	473.4	2.5	1187.1	512.7	2.2	1174.5	520.5	2.1
6.0	1374.7	331.0	3.8	1351.8	375.7	3.3	1325.2	424.9	2.9	1280.8	475.2	2.5	1216.1	514.6	2.2	1203.0	522.5	2.2
7.0	1412.9	333.8	3.9	1389.0	378.4	3.4	1361.1	427.8	3.0	1312.9	476.8	2.6	1246.0	516.4	2.3	1232.4	524.3	2.2
8.0	1451.9	336.8	4.0	1426.9	381.4	3.5	1397.9	430.7	3.0	1345.7	478.4	2.7	1276.5	518.2	2.3	1248.8	516.4	2.3
9.0	1491.4	340.1	4.0	1465.7	384.4	3.5	1435.3	433.8	3.1	1379.2	480.1	2.7	1307.7	519.9	2.4	1260.5	504.6	2.4
10.0	1531.8	343.5	4.1	1505.1	387.5	3.6	1473.6	436.9	3.2	1412.8	481.9	2.8	1339.2	521.7	2.4	1272.3	492.8	2.4
11.0	1572.9	347.0	4.2	1545.3	390.8	3.7	1512.7	440.1	3.2	1447.4	483.6	2.8	1356.6	512.7	2.5	1283.9	481.0	2.5
12.0	1613.6	350.8	4.2	1586.1	394.5	3.7	1552.4	443.5	3.3	1482.4	485.4	2.9	1369.0	500.1	2.6	1295.3	469.5	2.6
13.0	0.0	0.0	0.0	1626.5	398.0	3.8	1593.0	447.0	3.3	1518.1	487.2	2.9	1381.2	487.7	2.7	1306.2	458.5	2.7

<b>MODEL: YCIV1649P</b>																		
AIR TEMPERATURE ON - CONDENSER (°C)																		
LCWT (°C)	25.0			30.0			35.0			40.0			45.0			46.0		
	KW	KW	COP	KW	KW	COP	KW	KW	COP	KW	KW	COP	KW	KW	COP	KW	KW	COP
5.0	1,528.5	381.4	3.5	1,503.6	428.2	3.1	1,473.2	488.6	2.7	1,409.4	539.3	2.4	1,381.1	598.1	2.1	1,366.6	606.3	2.1
6.0	1,571.4	387.8	3.6	1,545.6	433.0	3.2	1,514.2	491.2	2.8	1,445.7	540.7	2.4	1,415.0	599.5	2.2	1,400.1	607.8	2.1
7.0	1,615.1	394.0	3.6	1,588.5	440.3	3.2	1,556.1	493.9	2.9	1,482.4	542.5	2.5	1,449.7	600.8	2.2	1,434.1	609.2	2.2
8.0	1,659.5	400.6	3.7	1,632.2	447.4	3.3	1,595.6	497.3	2.9	1,520.2	543.9	2.6	1,485.1	602.0	2.3	1,468.9	610.5	2.2
9.0	1,704.8	407.1	3.7	1,676.6	454.0	3.3	1,635.5	503.0	3.0	1,558.6	545.3	2.6	1,521.2	603.1	2.3	1,504.5	611.6	2.3
10.0	1,749.9	413.7	3.8	1,721.4	460.5	3.4	1,676.1	509.0	3.0	1,597.5	548.6	2.7	1,557.7	604.2	2.4	1,540.8	612.7	2.3
11.0	1,795.8	420.2	3.8	1,766.6	467.1	3.4	1,716.6	514.4	3.0	1,636.7	553.6	2.7	1,594.6	605.3	2.4	1,577.3	613.8	2.4
12.0	1,842.4	425.8	3.9	1,812.3	474.2	3.5	1,757.6	519.4	3.1	1,675.8	559.7	2.7	1,632.0	607.8	2.5	1,614.5	615.4	2.4
13.0	1,889.8	431.2	3.9	1,858.8	481.2	3.5	1,799.1	524.4	3.1	1,715.2	565.5	2.8	1,669.4	611.3	2.5	1,651.5	618.7	2.5

**NOTES:**

1. kW<sub>o</sub> = Unit kW Cooling Capacity Output
2. kW<sub>i</sub> = Compressor kW Input
3. COP = Coefficient of Performance (includes condenser fan power)
4. LCWT = Leaving Chilled Water Temperature
5. Ratings based on 0.168 l/s cooler water per ton, and 0.018 (m<sup>2</sup> - °C)/kW
6. AHRI 550/590 does not provide certification for 50Hz ratings. The unique use of the YCIV variable speed drive allows compressor operation at the output speed regardless of the input power frequency. This allows for common unit/heat exchanger configurations between 60Hz and 50Hz with closely matching capacity.

# High Efficiency Ratings - SI - 400V/50Hz

## MODEL: YCIV0590E/V

AIR TEMPERATURE ON - CONDENSER (°C)																		
LCWT (°C)	25.0			30.0			35.0			40.0			45.0			46.0		
	KW	KW	COP	KW	KW	COP	KW	KW	COP	KW	KW	COP	KW	KW	COP	KW	KW	COP
5.0	525.0	123.1	3.9	515.6	139.0	3.4	503.3	156.2	3.0	487.8	176.4	2.6	449.0	192.6	2.2	441.1	196.0	2.1
6.0	539.7	124.0	3.9	530.4	140.2	3.5	518.1	157.4	3.0	500.9	177.3	2.6	460.8	193.4	2.2	452.7	196.7	2.2
7.0	554.7	125.0	4.0	545.4	141.3	3.5	533.0	158.5	3.1	514.0	178.2	2.7	472.8	194.1	2.3	464.5	197.5	2.2
8.0	569.9	126.1	4.1	560.7	142.4	3.6	548.1	159.7	3.2	527.2	179.1	2.7	484.9	195.0	2.3	476.5	198.2	2.3
9.0	585.2	127.1	4.2	576.2	143.5	3.7	563.5	161.0	3.2	540.5	180.0	2.8	497.0	195.9	2.4	488.4	199.1	2.3
10.0	600.7	128.2	4.2	591.8	144.7	3.7	579.1	162.2	3.3	554.0	180.9	2.9	509.5	196.8	2.4	500.6	200.0	2.4
11.0	616.4	129.2	4.3	607.7	145.8	3.8	594.9	163.5	3.4	567.6	181.9	2.9	522.3	197.7	2.5	513.2	200.9	2.4
12.0	632.2	130.3	4.4	623.8	147.0	3.9	610.9	164.8	3.4	581.2	182.9	3.0	535.2	198.6	2.5	525.9	201.8	2.4
13.0	648.3	131.3	4.5	640.1	148.3	4.0	627.2	166.2	3.5	595.0	183.8	3.0	548.3	199.5	2.6	538.8	202.7	2.5

## MODEL: YCIV0630E/V

AIR TEMPERATURE ON - CONDENSER (°C)																		
LCWT (°C)	25.0			30.0			35.0			40.0			45.0			46.0		
	KW	KW	COP	KW	KW	COP	KW	KW	COP	KW	KW	COP	KW	KW	COP	KW	KW	COP
5.0	558.7	129.2	3.9	550.3	147.1	3.4	540.3	167.0	3.0	525.1	189.7	2.6	492.2	209.6	2.2	484.3	213.4	2.1
6.0	574.5	130.1	4.0	565.7	147.9	3.5	555.3	167.8	3.0	538.7	190.4	2.6	504.1	210.2	2.2	496.2	213.9	2.2
7.0	590.5	131.1	4.0	581.5	148.8	3.6	570.6	168.6	3.1	552.7	191.0	2.7	516.4	210.7	2.3	508.1	214.6	2.2
8.0	606.9	132.2	4.1	597.5	149.7	3.6	586.3	169.5	3.2	566.8	191.7	2.7	528.8	211.3	2.3	520.3	215.1	2.3
9.0	623.5	133.4	4.2	613.9	150.7	3.7	602.3	170.4	3.3	581.3	192.4	2.8	541.5	211.8	2.4	532.8	215.7	2.3
10.0	640.4	134.6	4.3	630.5	151.8	3.8	618.5	171.4	3.3	596.0	193.1	2.9	554.4	212.3	2.4	545.5	216.2	2.4
11.0	657.7	136.0	4.4	647.5	153.0	3.9	635.1	172.5	3.4	610.9	193.9	2.9	567.6	212.9	2.5	551.5	211.4	2.4
12.0	675.2	137.4	4.4	664.8	154.3	3.9	652.0	173.6	3.5	626.1	194.7	3.0	580.9	213.4	2.5	557.2	206.6	2.5
13.0	693.1	139.0	4.5	682.3	155.6	4.0	669.2	174.8	3.5	641.6	195.5	3.1	594.4	214.0	2.6	562.8	202.0	2.6

## MODEL: YCIV0700E/V

AIR TEMPERATURE ON - CONDENSER (°C)																		
LCWT (°C)	25.0			30.0			35.0			40.0			45.0			46.0		
	KW	KW	COP	KW	KW	COP	KW	KW	COP	KW	KW	COP	KW	KW	COP	KW	KW	COP
5.0	621.1	143.4	3.9	611.6	164.1	3.4	600.1	187.0	3.0	582.8	211.7	2.6	547.1	228.0	2.2	538.6	230.9	2.2
6.0	638.5	144.3	4.0	628.9	164.8	3.5	617.0	187.7	3.0	598.1	212.0	2.6	560.8	228.4	2.3	552.0	231.3	2.2
7.0	656.2	145.3	4.1	646.4	165.6	3.5	634.2	188.4	3.1	613.8	212.3	2.7	574.6	228.7	2.3	565.6	231.6	2.3
8.0	674.1	146.4	4.1	664.2	166.5	3.6	651.7	189.3	3.2	629.7	212.6	2.7	588.8	229.0	2.4	579.5	232.0	2.3
9.0	692.3	147.7	4.2	682.2	167.5	3.7	669.4	190.2	3.2	645.8	212.9	2.8	603.2	229.2	2.5	593.7	232.2	2.4
10.0	710.7	149.0	4.3	700.4	168.6	3.8	687.3	191.1	3.3	662.3	213.3	2.9	617.8	229.4	2.5	608.1	232.4	2.4
11.0	729.4	150.5	4.4	719.0	169.8	3.9	705.6	192.2	3.4	678.9	213.6	3.0	632.7	229.6	2.6	622.8	232.6	2.5
12.0	748.4	152.0	4.4	737.8	171.1	3.9	724.1	193.3	3.5	695.7	214.0	3.0	647.8	229.7	2.6	632.7	229.6	2.6
13.0	767.7	153.7	4.5	756.9	172.4	4.0	742.9	194.5	3.5	712.8	214.4	3.1	663.1	229.9	2.7	638.4	224.0	2.7

**NOTES:**

1. kW<sub>o</sub> = Unit kW Cooling Capacity Output
2. kW<sub>i</sub> = Compressor kW Input
3. COP = Coefficient of Performance (includes condenser fan power)
4. LCWT = Leaving Chilled Water Temperature
5. Ratings based on 0.168 l/s cooler water per ton, and 0.018 (m<sup>2</sup> - °C)/kW
6. AHRI 550/590 does not provide certification for 50Hz ratings. The unique use of the YCIV variable speed drive allows compressor operation at the output speed regardless of the input power frequency. This allows for common unit/heat exchanger configurations between 60Hz and 50Hz with closely matching capacity.

<b>MODEL: YCIV0760E/V</b>																		
AIR TEMPERATURE ON - CONDENSER (°C)																		
LCWT (°C)	25.0			30.0			35.0			40.0			45.0			46.0		
	KW	KW	COP	KW	KW	COP	KW	KW	COP	KW	KW	COP	KW	KW	COP	KW	KW	COP
5.0	672.7	155.1	3.9	661.6	178.9	3.4	648.7	206.1	2.9	631.4	236.7	2.5	607.1	255.6	2.2	599.3	258.2	2.2
6.0	691.7	156.1	4.0	680.1	179.4	3.5	666.7	206.4	3.0	647.0	236.3	2.6	621.7	255.7	2.3	613.7	258.5	2.2
7.0	711.0	157.3	4.1	699.0	180.0	3.6	685.1	206.8	3.1	662.9	235.8	2.6	636.5	255.7	2.3	628.4	258.5	2.3
8.0	730.8	158.7	4.2	718.3	180.9	3.6	703.9	207.3	3.1	678.8	235.3	2.7	651.7	255.5	2.4	643.3	258.4	2.3
9.0	750.9	160.4	4.2	737.9	181.8	3.7	723.0	207.9	3.2	695.2	234.8	2.8	667.2	255.2	2.5	658.5	258.2	2.4
10.0	771.3	162.3	4.3	758.0	183.0	3.8	742.4	208.8	3.3	711.9	234.3	2.8	682.9	254.8	2.5	674.0	257.8	2.4
11.0	792.1	164.4	4.4	778.4	184.3	3.9	762.2	209.6	3.4	728.8	233.8	2.9	698.9	254.3	2.6	689.7	257.4	2.5
12.0	813.3	166.8	4.4	799.1	186.0	3.9	782.4	210.6	3.4	745.9	233.3	3.0	715.0	253.9	2.6	705.0	256.5	2.6
13.0	834.9	169.5	4.5	820.2	187.8	4.0	803.0	211.8	3.5	763.0	233.0	3.1	731.6	253.3	2.7	710.9	249.9	2.6

<b>MODEL: YCIV0800E/V</b>																		
AIR TEMPERATURE ON - CONDENSER (°C)																		
LCWT (°C)	25.0			30.0			35.0			40.0			45.0			46.0		
	KW	KW	COP	KW	KW	COP	KW	KW	COP	KW	KW	COP	KW	KW	COP	KW	KW	COP
5.0	715.1	163.2	3.9	703.9	187.3	3.4	691.1	214.8	3.0	672.4	245.0	2.6	652.7	267.8	2.3	644.7	270.6	2.2
6.0	735.3	164.3	4.0	723.6	188.0	3.5	710.2	215.4	3.0	689.7	245.2	2.6	668.3	267.9	2.3	660.0	270.8	2.3
7.0	755.9	165.6	4.1	743.7	188.9	3.6	729.7	216.0	3.1	707.4	245.3	2.7	684.3	267.8	2.4	675.7	270.9	2.3
8.0	776.9	167.1	4.2	764.2	189.8	3.7	749.5	216.7	3.2	725.4	245.4	2.8	700.4	267.7	2.5	691.7	270.8	2.4
9.0	798.4	168.8	4.3	785.1	191.0	3.8	769.8	217.5	3.3	743.7	245.5	2.8	717.0	267.5	2.5	707.9	270.6	2.5
10.0	820.2	170.7	4.3	806.4	192.3	3.8	790.5	218.4	3.3	762.5	245.6	2.9	733.7	267.2	2.6	716.0	265.3	2.5
11.0	842.4	172.9	4.4	828.1	193.8	3.9	811.6	219.5	3.4	781.3	245.8	3.0	750.9	266.8	2.6	722.8	258.9	2.6
12.0	864.5	175.1	4.5	850.1	195.4	4.0	833.1	220.7	3.5	799.5	245.5	3.0	768.2	266.5	2.7	729.6	252.5	2.7
13.0	887.0	177.7	4.5	872.1	197.2	4.0	854.8	222.1	3.6	818.1	245.3	3.1	780.0	262.5	2.8	735.8	246.0	2.8

<b>MODEL: YCIV0830E/V</b>																		
AIR TEMPERATURE ON - CONDENSER (°C)																		
LCWT (°C)	25.0			30.0			35.0			40.0			45.0			46.0		
	KW	KW	COP	KW	KW	COP	KW	KW	COP	KW	KW	COP	KW	KW	COP	KW	KW	COP
5.0	743.0	169.0	3.9	731.8	192.7	3.4	718.8	219.4	3.0	703.0	250.7	2.6	685.2	275.1	2.3	676.9	278.2	2.3
6.0	764.0	170.2	4.0	752.3	193.7	3.5	738.8	220.3	3.1	722.2	251.7	2.7	701.8	275.3	2.4	693.2	278.4	2.3
7.0	785.4	171.7	4.1	773.3	194.8	3.6	759.2	221.2	3.2	741.8	252.8	2.7	718.6	275.4	2.4	709.9	278.5	2.4
8.0	807.2	173.1	4.2	794.7	196.0	3.7	780.0	222.3	3.2	761.9	253.8	2.8	735.8	275.5	2.5	726.7	278.6	2.4
9.0	829.4	174.8	4.3	816.5	197.2	3.8	801.2	223.4	3.3	782.3	254.8	2.9	753.3	275.4	2.6	744.0	278.6	2.5
10.0	851.7	176.5	4.3	838.7	198.7	3.8	822.9	224.6	3.4	801.1	254.8	2.9	771.2	275.4	2.6	761.5	278.5	2.6
11.0	874.2	178.4	4.4	860.8	200.2	3.9	844.9	225.8	3.4	820.0	254.9	3.0	789.1	275.4	2.7	779.4	278.5	2.6
12.0	897.1	180.5	4.5	883.2	201.8	4.0	866.8	227.3	3.5	839.3	254.9	3.1	807.6	275.3	2.7	797.4	278.4	2.7
13.0	920.3	182.6	4.5	906.1	203.6	4.1	889.1	228.7	3.6	858.7	255.0	3.1	826.3	275.2	2.8	815.9	278.3	2.7

**NOTES:**

1. kW<sub>o</sub> = Unit kW Cooling Capacity Output
2. kW<sub>i</sub> = Compressor kW Input
3. COP = Coefficient of Performance (includes condenser fan power)
4. LCWT = Leaving Chilled Water Temperature
5. Ratings based on 0.168 l/s cooler water per ton, and 0.018 (m<sup>2</sup> - °C)/kW
6. AHRI 550/590 does not provide certification for 50Hz ratings. The unique use of the YCIV variable speed drive allows compressor operation at the output speed regardless of the input power frequency. This allows for common unit/heat exchanger configurations between 60Hz and 50Hz with closely matching capacity.

# High Efficiency Ratings - SI - 400V/50Hz

## MODEL: YCIV0930E/V

AIR TEMPERATURE ON - CONDENSER (°C)																		
LCWT (°C)	25.0			30.0			35.0			40.0			45.0			46.0		
	KW	KW	COP	KW	KW	COP	KW	KW	COP	KW	KW	COP	KW	KW	COP	KW	KW	COP
5.0	824.5	194.8	3.8	811.2	221.5	3.4	795.7	251.2	2.9	773.5	283.8	2.5	730.4	305.9	2.2	721.2	309.7	2.2
6.0	847.7	196.4	3.9	833.8	222.9	3.4	817.7	252.6	3.0	793.8	284.9	2.6	748.4	306.5	2.3	738.8	310.5	2.2
7.0	871.3	198.1	4.0	856.9	224.4	3.5	840.1	254.0	3.1	814.6	286.0	2.7	766.7	307.1	2.3	754.9	309.8	2.3
8.0	895.3	199.9	4.1	880.5	226.0	3.6	863.0	255.6	3.1	835.8	287.1	2.7	785.5	307.7	2.4	763.0	303.6	2.4
9.0	919.9	201.9	4.1	904.5	227.8	3.7	886.3	257.2	3.2	856.8	287.9	2.8	804.7	308.2	2.5	770.6	296.9	2.4
10.0	944.8	204.0	4.2	928.9	229.6	3.7	910.1	258.9	3.3	877.5	288.5	2.8	821.6	307.2	2.5	777.9	289.9	2.5
11.0	970.3	206.2	4.3	953.8	231.6	3.8	934.4	260.7	3.3	898.6	289.1	2.9	829.7	300.0	2.6	784.7	282.6	2.6
12.0	995.9	208.6	4.4	979.1	233.6	3.9	959.0	262.6	3.4	920.1	289.7	3.0	837.3	292.4	2.7	791.0	275.3	2.7
13.0	1022.2	210.5	4.4	1004.7	235.9	3.9	984.2	264.6	3.5	941.9	290.4	3.0	844.2	284.8	2.8	796.8	268.3	2.8

## MODEL: YCIV1050E/V

AIR TEMPERATURE ON - CONDENSER (°C)																		
LCWT (°C)	25.0			30.0			35.0			40.0			45.0			46.0		
	KW	KW	COP	KW	KW	COP	KW	KW	COP	KW	KW	COP	KW	KW	COP	KW	KW	COP
5.0	935.9	214.3	3.9	919.5	246.0	3.4	900.1	281.3	3.0	875.5	321.9	2.5	811.1	342.9	2.2	798.1	346.7	2.2
6.0	962.5	215.7	4.0	945.8	247.0	3.5	925.6	282.3	3.0	898.2	322.2	2.6	831.3	343.3	2.3	817.8	347.2	2.2
7.0	989.5	217.3	4.1	972.5	248.1	3.6	951.7	283.3	3.1	921.3	322.3	2.7	851.9	343.6	2.3	838.0	347.6	2.3
8.0	1017.1	219.1	4.2	999.6	249.4	3.7	978.3	284.3	3.2	944.1	322.3	2.7	872.7	343.8	2.4	858.7	347.9	2.3
9.0	1045.2	221.1	4.3	1027.4	250.9	3.7	1005.4	285.5	3.3	967.3	322.3	2.8	894.2	343.9	2.4	879.6	348.1	2.4
10.0	1073.8	223.4	4.4	1055.6	252.5	3.8	1033.0	286.9	3.3	991.0	322.2	2.9	915.8	344.0	2.5	901.0	348.2	2.4
11.0	1102.8	225.9	4.4	1084.4	254.3	3.9	1061.2	288.3	3.4	1015.0	322.2	2.9	938.0	344.0	2.6	922.6	348.2	2.5
12.0	1132.3	228.7	4.5	1113.6	256.4	4.0	1089.8	289.9	3.5	1039.3	322.2	3.0	960.5	344.0	2.6	944.8	348.2	2.5
13.0	1162.3	231.7	4.6	1143.3	258.7	4.1	1119.1	291.7	3.6	1063.8	322.3	3.1	983.3	344.0	2.7	967.4	348.1	2.6

## MODEL: YCIV1120E/V

AIR TEMPERATURE ON - CONDENSER (°C)																		
LCWT (°C)	25.0			30.0			35.0			40.0			45.0			46.0		
	KW	KW	COP	KW	KW	COP	KW	KW	COP	KW	KW	COP	KW	KW	COP	KW	KW	COP
5.0	996.2	225.3	4.0	979.2	259.7	3.4	959.5	298.8	3.0	935.5	344.4	2.5	869.0	364.4	2.2	855.4	367.7	2.2
6.0	1024.5	226.7	4.1	1007.0	260.4	3.5	986.4	299.5	3.0	960.5	344.8	2.6	890.3	364.4	2.3	876.3	367.9	2.2
7.0	1053.4	228.4	4.2	1035.3	261.3	3.6	1013.9	300.0	3.1	984.3	344.2	2.7	912.1	364.3	2.3	897.7	367.9	2.3
8.0	1082.9	230.4	4.2	1064.2	262.5	3.7	1042.0	300.7	3.2	1008.6	343.5	2.7	934.3	363.9	2.4	919.5	367.6	2.3
9.0	1112.9	232.7	4.3	1093.7	263.9	3.8	1070.7	301.6	3.3	1033.1	342.9	2.8	956.7	363.5	2.5	941.8	367.2	2.4
10.0	1143.5	235.4	4.4	1123.7	265.6	3.9	1100.0	302.8	3.4	1058.1	342.2	2.9	979.9	362.9	2.5	964.3	366.8	2.5
11.0	1174.4	238.5	4.5	1154.4	267.5	3.9	1129.9	304.0	3.4	1083.6	341.5	3.0	1003.4	362.3	2.6	987.4	366.2	2.5
12.0	1206.4	241.9	4.5	1185.5	269.8	4.0	1160.4	305.5	3.5	1109.5	340.9	3.0	1027.4	361.6	2.7	1011.0	365.5	2.6
13.0	1238.7	245.7	4.6	1217.3	272.4	4.1	1191.4	307.2	3.6	1135.6	340.4	3.1	1051.7	360.9	2.7	1034.9	364.8	2.7

**NOTES:**

1. kW<sub>o</sub> = Unit kW Cooling Capacity Output
2. kW<sub>i</sub> = Compressor kW Input
3. COP = Coefficient of Performance (includes condenser fan power)
4. LCWT = Leaving Chilled Water Temperature
5. Ratings based on 0.168 l/s cooler water per ton, and 0.018 (m<sup>2</sup> - °C)/kW
6. AHRI 550/590 does not provide certification for 50Hz ratings. The unique use of the YCIV variable speed drive allows compressor operation at the output speed regardless of the input power frequency. This allows for common unit/heat exchanger configurations between 60Hz and 50Hz with closely matching capacity.

**MODEL: YCIV1220E/V**

AIR TEMPERATURE ON - CONDENSER (°C)																		
LCWT (°C)	25.0			30.0			35.0			40.0			45.0			46.0		
	KW	KW	COP	KW	KW	COP	KW	KW	COP	KW	KW	COP	KW	KW	COP	KW	KW	COP
5.0	1082.7	247.9	3.9	1064.7	284.7	3.4	1044.3	326.4	3.0	1013.0	371.0	2.6	945.2	394.1	2.3	930.6	397.6	2.2
6.0	1113.5	249.6	4.0	1094.7	285.8	3.5	1073.2	327.3	3.0	1038.5	371.1	2.6	967.8	394.2	2.3	953.0	397.8	2.2
7.0	1145.0	251.6	4.1	1125.3	287.1	3.6	1102.8	328.3	3.1	1064.7	371.1	2.7	991.1	394.1	2.4	975.8	397.9	2.3
8.0	1177.1	253.9	4.2	1156.5	288.5	3.7	1133.0	329.5	3.2	1091.4	371.0	2.7	1014.9	393.9	2.4	999.0	397.7	2.4
9.0	1209.8	256.5	4.3	1188.4	290.3	3.8	1164.0	330.7	3.3	1118.6	370.9	2.8	1039.0	393.5	2.5	1022.8	397.4	2.4
10.0	1243.2	259.3	4.3	1221.0	292.3	3.8	1195.5	332.2	3.3	1146.4	370.9	2.9	1063.6	393.0	2.5	1047.0	397.0	2.5
11.0	1277.2	262.6	4.4	1254.2	294.7	3.9	1227.8	333.8	3.4	1174.3	370.9	3.0	1088.5	392.5	2.6	1071.6	396.5	2.5
12.0	1311.9	266.1	4.5	1288.1	297.2	4.0	1260.7	335.7	3.5	1201.8	370.4	3.0	1114.1	391.9	2.7	1085.7	389.4	2.6
13.0	1347.3	270.1	4.5	1322.6	300.0	4.1	1294.1	337.9	3.6	1229.8	370.1	3.1	1139.9	391.3	2.7	1095.0	379.4	2.7

**MODEL: YCIV1380E/V**

AIR TEMPERATURE ON - CONDENSER (°C)																		
LCWT (°C)	25.0			30.0			35.0			40.0			45.0			46.0		
	KW	KW	COP	KW	KW	COP	KW	KW	COP	KW	KW	COP	KW	KW	COP	KW	KW	COP
5.0	1228.4	287.0	3.9	1206.7	325.4	3.4	1181.0	367.8	3.0	1146.5	415.9	2.6	1083.9	450.5	2.3	1070.4	456.8	2.2
6.0	1263.2	289.6	4.0	1241.1	327.6	3.5	1214.5	370.0	3.0	1177.1	417.5	2.6	1111.7	451.6	2.3	1097.6	457.9	2.3
7.0	1298.8	292.2	4.0	1276.1	330.0	3.5	1248.7	372.3	3.1	1208.5	419.0	2.7	1139.9	452.8	2.4	1125.5	459.0	2.3
8.0	1334.9	295.0	4.1	1311.8	332.6	3.6	1283.4	374.9	3.2	1240.5	420.6	2.8	1168.8	453.8	2.4	1153.8	460.1	2.4
9.0	1371.6	298.1	4.2	1348.0	335.4	3.7	1318.9	377.4	3.2	1273.1	422.2	2.8	1198.3	454.9	2.5	1183.0	461.2	2.4
10.0	1409.1	301.3	4.3	1384.9	338.3	3.8	1355.0	380.2	3.3	1306.1	424.0	2.9	1228.4	456.0	2.5	1205.0	457.4	2.5
11.0	1447.1	304.6	4.3	1422.5	341.3	3.8	1391.8	383.1	3.4	1339.8	425.7	2.9	1258.9	457.1	2.6	1215.9	446.2	2.6
12.0	1485.7	308.3	4.4	1460.6	344.7	3.9	1429.2	386.1	3.4	1372.9	427.0	3.0	1290.1	458.2	2.6	1226.3	435.1	2.6
13.0	1525.2	311.0	4.5	1499.4	348.1	4.0	1467.3	389.3	3.5	1406.5	428.4	3.1	1308.1	450.8	2.7	1236.0	424.3	2.7

**NOTES:**

1. kW<sub>o</sub> = Unit kW Cooling Capacity Output
2. kW<sub>i</sub> = Compressor kW Input
3. COP = Coefficient of Performance (includes condenser fan power)
4. LCWT = Leaving Chilled Water Temperature
5. Ratings based on 0.168 l/s cooler water per ton, and 0.018 (m<sup>2</sup> – °C)/kW
6. AHRI 550/590 does not provide certification for 50Hz ratings. The unique use of the YCIV variable speed drive allows compressor operation at the output speed regardless of the input power frequency. This allows for common unit/heat exchanger configurations between 60Hz and 50Hz with closely matching capacity.

# Physical Data (SI - Standard Efficiency)

FORM 201.23-EG2 (713)

REFRIGERANT R-134A	STANDARD EFFICIENCY							
	MODEL NUMBER (YCIV ___ S/P)							
	50HZ	0600	0650	0720	0770	0840	0920	1000
<b>NUMBER OF INDEPENDENT REFRIGERANT CIRCUITS</b>	2	2	2	2	2	2	2	2
REFRIGERANT CHARGE, R-134A, CKT.-1/CKT.-2, KG.	74/74	77/77	84/77	87/80	87/87	105/89	105/105	105/105
OIL CHARGE, CKT.-1/CKT.-2, LITERS	19/19	19/19	19/19	19/19	19/19	19/19	19/19	19/19
COMPRESSORS, SEMIHERMETIC SCREW QTY PER CHILLER	2	2	2	2	2	2	2	2
<b>CONDENSERS, HIGH EFFICIENCY FIN/TUBE WITH INTEGRAL SUBCOOLER</b>								
TOTAL CHILLER COIL FACE AREA, M <sup>2</sup>	21.8	21.8	24.5	24.5	27.2	30.0	32.7	32.7
NUMBER OF ROWS	3	3	3	3	3	3	3	3
FINS PER METER	669	669	669	669	669	669	669	669
<b>CONDENSER FANS</b>								
NUMBER, CKT.-1/CKT.-2	4/4	4/4	5/4	5/4	5/5	6/5	6/6	6/6
<b>LOW NOISE FANS</b>								
FAN MOTOR, HP/KWI	2/1.50	2/1.50	2/1.50	2/1.50	2/1.50	2/1.50	2/1.50	2/1.50
TOTAL CHILLER AIRFLOW, L/SEC.	49082	49082	55218	55218	61353	67488	73624	73624
<b>ULTRA QUIET FANS</b>								
FAN MOTOR, HP/KWI	2/1.50	2/1.50	2/1.50	2/1.50	2/1.50	2/1.50	2/1.50	2/1.50
TOTAL CHILLER AIRFLOW, L/SEC.	49082	49082	55218	55218	61353	67488	73624	73624
<b>DUAL SPEED FANS - NORMAL SPEED</b>								
FAN, KWI	1.5	1.5	1.5	1.5	1.5	1.5	1.5	1.5
TOTAL CHILLER, M <sup>3</sup> /S	42	42	47	47	52	57	62	62
<b>DUAL SPEED FANS - LOWER SPEED</b>								
FAN, KWI	1.5	1.5	1.5	1.5	1.5	1.5	1.5	1.5
TOTAL CHILLER, M <sup>3</sup> /S	32	32	36	36	40	44	48	48
<b>HIGH STATIC FANS</b>								
FAN, KWI	3.7	3.7	3.7	3.7	3.7	3.7	3.7	3.7
TOTAL CHILLER, M <sup>3</sup> /S	49	49	55	55	61	67	74	74
<b>EVAPORATOR, DIRECT EXPANSION</b>								
WATER VOLUME, LITERS	253.6	359.6	359.6	529.9	529.9	529.9	529.9	529.9
MAXIMUM WATER SIDE PRESSURE, BAR <sup>1</sup>	10	10	10	10	10	10	10	10
MAXIMUM REFRIGERANT SIDE PRESSURE, BAR	16	16	16	16	16	16	16	16
MINIMUM CHILLED WATER FLOW RATE, L/SEC.	8.8	10.1	10.1	11.4	11.4	11.4	11.4	11.4
MAXIMUM CHILLED WATER FLOW RATE, L/SEC.	42.6	47.3	47.3	50.5	50.5	50.5	50.5	50.5
WATER CONNECTIONS, INCHES	8	10	10	10	10	10	10	10

Contact your nearest Johnson Controls Sales Office for weight data.

REFRIGERANT R-134A	STANDARD EFFICIENCY					
	MODEL NUMBER (YCIV ___ S/P)					
	50HZ	1070	1180	1340	1500	1649
<b>NUMBER OF INDEPENDENT REFRIGERANT CIRCUITS</b>	3	3	3	3	3	4
REFRIGERANT CHARGE, R-134A, CKT.-1/CKT.-2, KG.	84 / 77 / 77	84 / 84 / 77	84 / 84 / 105	105 / 105 / 105	142/142/137/137	
OIL CHARGE, CKT.-1/CKT.-2, LITERS	19 / 15 / 15	19 / 19 / 15	19 / 19 / 19	19 / 19 / 19	19/19/19/19	
GLYCOL CHARGE (43% CONCENTRATION), LITERS	0	0	0	0	0	
COMPRESSORS, SEMIHERMETIC SCREW QTY PER CHILLER	3	3	3	3	3	4
<b>CONDENSERS, HIGH EFFICIENCY FIN/TUBE WITH INTEGRAL SUBCOOLER</b>						
TOTAL CHILLER COIL FACE AREA, M <sup>2</sup>	35	38	44	49	49	
NUMBER OF ROWS	3	3	3	3	3	4
FINS PER METER	669	669	669	669	669	669
<b>CONDENSER FANS</b>						
NUMBER, CKT.-1/CKT.-2	5/4/4	5/5/4	5/5/6	6/6/6	6/6/3/3	
<b>LOW NOISE FANS</b>						
FAN MOTOR, HP/KWI	2/1.50	2/1.50	2/1.50	2/1.50	2/1.50	2/1.50
TOTAL CHILLER AIRFLOW, L/SEC.	79768	85904	98176	110448	110448	
<b>ULTRA QUIET FANS</b>						
FAN MOTOR, HP/KWI	2/1.50	2/1.50	2/1.50	2/1.50	2/1.50	2/1.50
TOTAL CHILLER AIRFLOW, L/SEC.	79768	85904	98176	110448	110448	
<b>DUAL SPEED FANS - NORMAL SPEED</b>						
FAN, KWI	1.5	1.5	1.5	1.5	1.5	1.5
TOTAL CHILLER, M <sup>3</sup> /S	67	67	78	78	78	
<b>DUAL SPEED FANS - LOWER SPEED</b>						
FAN, KWI	1.5	1.5	1.5	1.5	1.5	1.5
TOTAL CHILLER, M <sup>3</sup> /S	52	52	59	59	59	
<b>HIGH STATIC FANS</b>						
FAN, KWI	3.7	3.7	3.7	3.7	3.7	3.7
TOTAL CHILLER, M <sup>3</sup> /S	80	86	98	110	110	
<b>EVAPORATOR, DIRECT EXPANSION</b>						
WATER VOLUME, LITERS	764.6	893.3	893.3	893.3	893.3	318
MAXIMUM WATER SIDE PRESSURE, BAR	10	10	10	10	10	10
MAXIMUM REFRIGERANT SIDE PRESSURE, BAR	16	16	16	16	16	16
MINIMUM CHILLED WATER FLOW RATE, L/SEC.	16	19	19	19	19	25
MAXIMUM CHILLED WATER FLOW RATE, L/SEC.	76	76	76	76	76	89
WATER CONNECTIONS, INCHES	10	10	10	10	10	10

Contact your nearest Johnson Controls Sales Office for weight data.

# Physical Data (SI - High Efficiency)

REFRIGERANT R-134A	HIGH EFFICIENCY							
	MODEL NUMBER (YCIV ___ E/V)							
	50HZ	0590	0630	0700	0760	0800	0830	0930
<b>NUMBER OF INDEPENDENT REFRIGERANT CIRCUITS</b>	2	2	2	2	2	2	2	2
REFRIGERANT CHARGE, R-134A, CKT.-1/CKT.-2, KG.	77/77	84/77	84/84	87/87	102/87	102/102	105/105	
OIL CHARGE, CKT.-1/CKT.-2, LITERS	19/19	19/19	19/19	19/19	19/19	19/19	19/19	
COMPRESSORS, SEMIHERMETIC SCREW QTY PER CHILLER	2	2	2	2	2	2	2	
<b>CONDENSERS, HIGH EFFICIENCY FIN/TUBE WITH INTEGRAL SUBCOOLER</b>								
TOTAL CHILLER COIL FACE AREA, M <sup>2</sup>	21.8	24.5	27.2	27.2	30.0	32.7	32.7	
NUMBER OF ROWS	3	3	3	3	3	3	3	
FINS PER METER	669	669	669	669	669	669	669	
<b>CONDENSER FANS</b>								
NUMBER, CKT.-1/CKT.-2	4/4	5/4	5/5	5/5	6/5	6/6	6/6	
<b>LOW SOUND FANS</b>								
FAN MOTOR, HP/KWI	2/1.50	2/1.50	2/1.50	2/1.50	2/1.50	2/1.50	2/1.50	
TOTAL CHILLER AIRFLOW, L/SEC.	49082	55218	61353	61353	67488	73624	73624	
<b>ULTRA QUIET FANS</b>								
FAN MOTOR, HP/KWI	2/1.50	2/1.50	2/1.50	2/1.50	2/1.50	2/1.50	2/1.50	
TOTAL CHILLER AIRFLOW, L/SEC.	49082	55218	61353	61353	67488	73624	73624	
<b>DUAL SPEED FANS - NORMAL SPEED</b>								
FAN, KWI	1.5	1.5	1.5	1.5	1.5	1.5	1.5	
TOTAL CHILLER, M <sup>3</sup> /S	42	47	52	52	57	62	62	
<b>DUAL SPEED FANS - LOWER SPEED</b>								
FAN, KWI	1.5	1.5	1.5	1.5	1.5	1.5	1.5	
TOTAL CHILLER, M <sup>3</sup> /S	32	36	40	40	44	48	48	
<b>HIGH STATIC FANS</b>								
FAN, KWI	3.7	3.7	3.7	3.7	3.7	3.7	3.7	
TOTAL CHILLER, M <sup>3</sup> /S	49	55	61	61	67	74	74	
<b>EVAPORATOR, DIRECT EXPANSION</b>								
WATER VOLUME, LITERS	359.6	359.6	359.6	416.4	416.4	416.4	529.9	
MAXIMUM WATER SIDE PRESSURE, BAR <sup>1</sup>	10	10	10	10	10	10	10	
MAXIMUM REFRIGERANT SIDE PRESSURE, BAR	16	16	16	16	16	16	16	
MINIMUM CHILLED WATER FLOW RATE, L/SEC.	10.1	10.1	10.1	11.4	11.4	11.4	11.4	
MAXIMUM CHILLED WATER FLOW RATE, L/SEC.	47.3	47.3	47.3	47.3	47.3	47.3	50.5	
WATER CONNECTIONS, INCHES	10	10	10	10	10	10	10	

Contact your nearest Johnson Controls Sales Office for weight data.



REFRIGERANT R-134A	HIGH EFFICIENCY				
	MODEL NUMBER (YCIV ___ E/V)				
	50HZ	1050	1120	1220	1380
<b>NUMBER OF INDEPENDENT REFRIGERANT CIRCUITS</b>	3	3	3	3	3
REFRIGERANT CHARGE, R-134A, CKT.-1/CKT.-2, KG.	84 / 84 / 77	84 / 84 / 105	84 / 84 / 105	84 / 84 / 105	105 / 105 / 105
OIL CHARGE, CKT.-1/CKT.-2, LITERS	19 / 19 / 15	19 / 19 / 19	19 / 19 / 19	19 / 19 / 19	19 / 19 / 19
GLYCOL CHARGE (43% CONCENTRATION), LITERS	0	0	0	0	0
COMPRESSORS, SEMIHERMETIC SCREW QTY PER CHILLER	3	3	3	3	3
<b>CONDENSERS, HIGH EFFICIENCY FIN/TUBE WITH INTEGRAL SUBCOOLER</b>					
TOTAL CHILLER COIL FACE AREA, M <sup>2</sup>	38	44	44	44	49
NUMBER OF ROWS	3	3	3	3	3
FINS PER METER	669	669	669	669	669
<b>CONDENSER FANS</b>					
NUMBER, CKT.-1/CKT.-2	05/05/04	05/05/06	05/05/06	05/05/06	06/06/06
<b>LOW NOISE FANS</b>					
FAN MOTOR, HP/KWI	2/1.50	2/1.50	2/1.50	2/1.50	2/1.50
TOTAL CHILLER AIRFLOW, L/SEC.	85904	98176	98176	98176	110448
<b>ULTRA QUIET FANS</b>					
FAN MOTOR, HP/KWI	2/1.50	2/1.50	2/1.50	2/1.50	2/1.50
TOTAL CHILLER AIRFLOW, L/SEC.	85904	98176	98176	98176	110448
<b>DUAL SPEED FANS - NORMAL SPEED</b>					
FAN, KWI	1.5	1.5	1.5	1.5	1.5
TOTAL CHILLER, M <sup>3</sup> /S	73	83	83	83	93
<b>DUAL SPEED FANS - LOWER SPEED</b>					
FAN, KWI	1.5	1.5	1.5	1.5	1.5
TOTAL CHILLER, M <sup>3</sup> /S	56	63	63	63	71
<b>HIGH STATIC FANS</b>					
FAN, KWI	3.7	3.7	3.7	3.7	3.7
TOTAL CHILLER, M <sup>3</sup> /S	92	117	117	117	129
<b>EVAPORATOR, DIRECT EXPANSION</b>					
WATER VOLUME, LITERS	764.6	764.6	893.3	893.3	893.3
MAXIMUM WATER SIDE PRESSURE, BAR	10	10	10	10	10
MAXIMUM REFRIGERANT SIDE PRESSURE, BAR	16	16	16	16	16
MINIMUM CHILLED WATER FLOW RATE, L/SEC.	16	16	19	19	19
MAXIMUM CHILLED WATER FLOW RATE, L/SEC.	76	76	76	76	76
WATER CONNECTIONS, INCHES	10	10	10	10	10

Contact your nearest Johnson Controls Sales Office for weight data.

## YCIV0590E/V and YCIV0600S/P

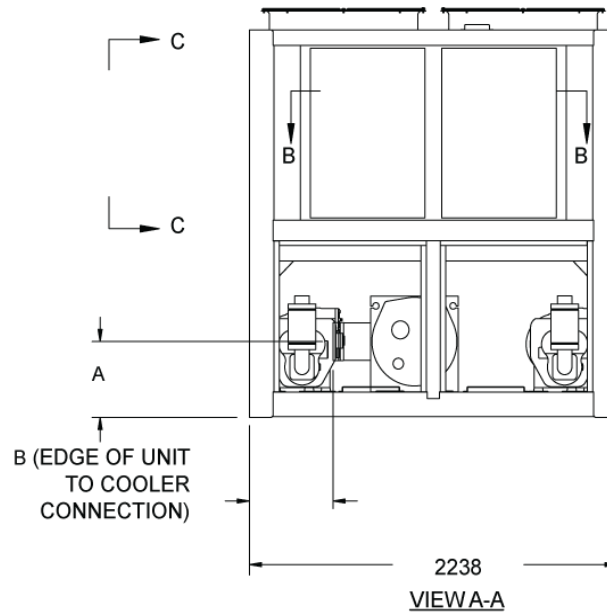
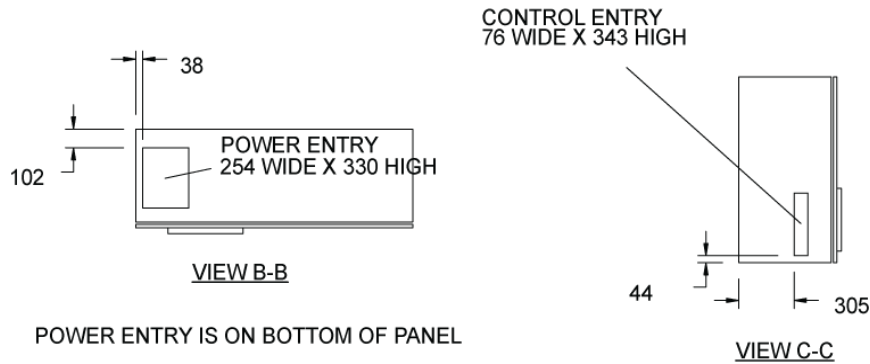

YCIV	A	B	C	D
0590E/V	485	714	2146	2865
0600S/P	442	739	2286	2797

**Notes:**

1. Placement on a level surface free of obstructions (including snow, for winter operation) or air recirculation ensures rated performance, reliable operation, and ease of maintenance. Site restrictions may compromise minimum clearances indicated below, resulting in unpredictable air patterns and possible diminished performance. Johnson Controls' unit controls will optimize the operation without nuisance high pressure safety cutouts; however, the system designer **MUST** consider potential performance degradation.

Access to the unit control center stipulates the unit is no higher than on spring isolators. Recommended minimum clearances: side to wall - 2m; rear to wall - 2m; control panel end to wall - 1.2m; top - no obstructions whatsoever; distance between adjacent units - 10'. No more than one adjacent wall may be higher than the unit.

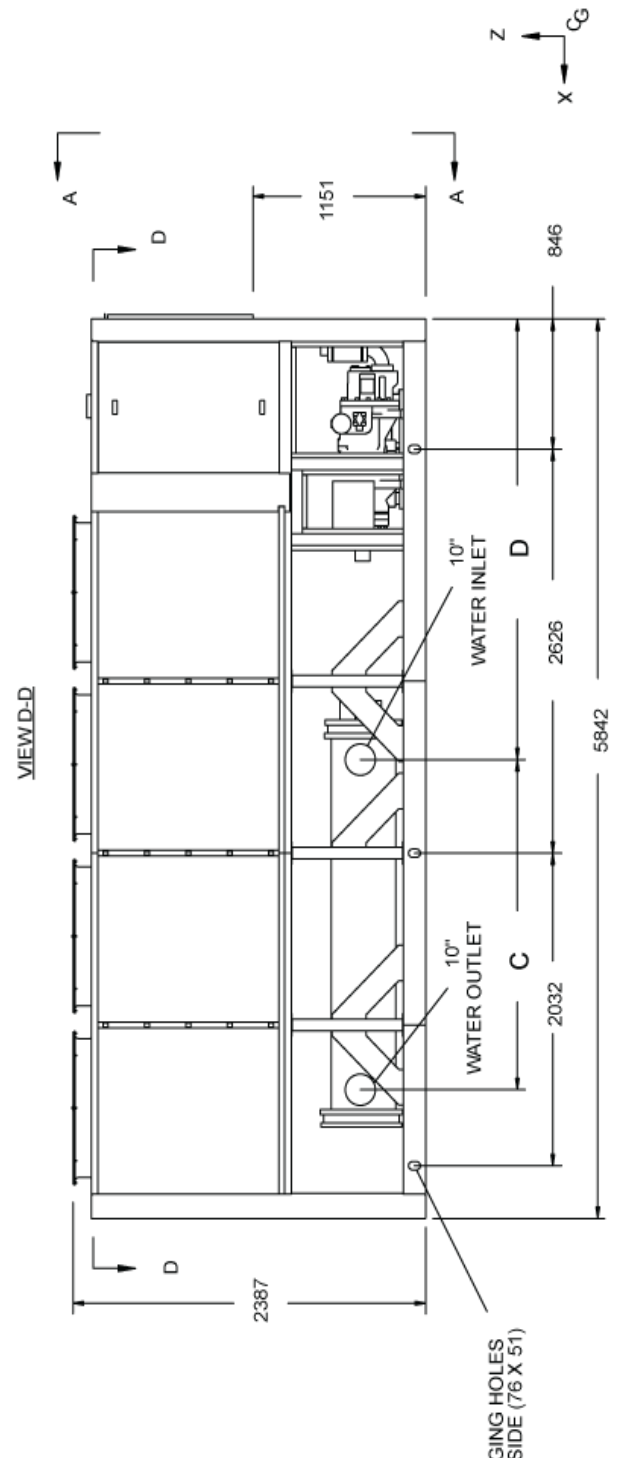
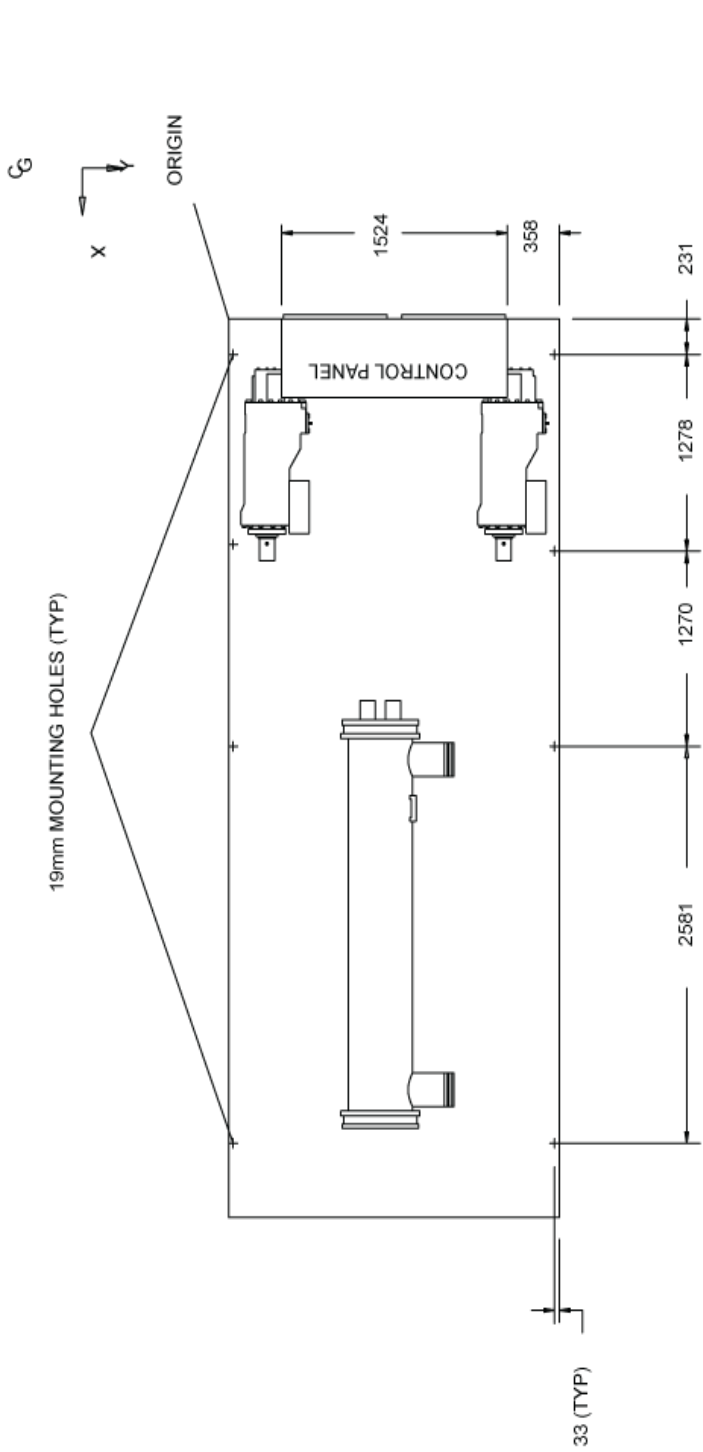

## YCIV0630E/V, YCIV0650S/P, YCIV0700E/V and YCIV0720S/P

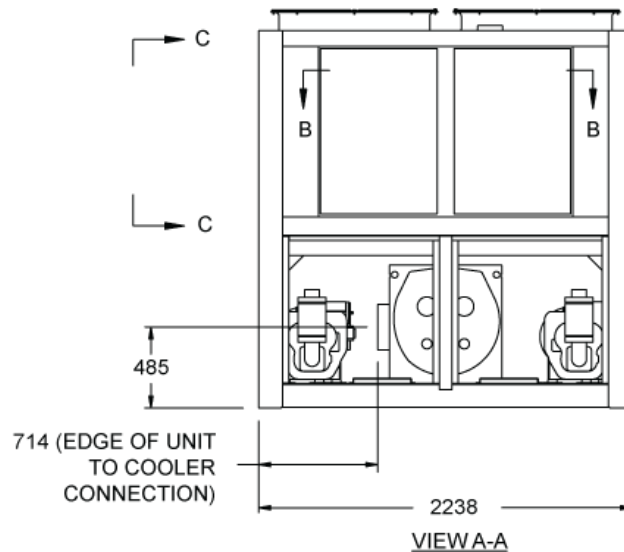
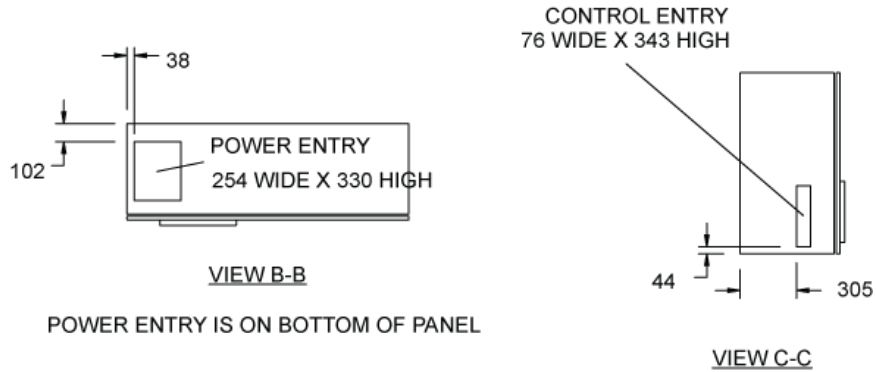

YCIV	A	B
06307E/V	2238	6960
0650S/P	2032	5842
0700E/V	2238	6960
0720S/P	2238	6960

**Notes:**

1. Placement on a level surface free of obstructions (including snow, for winter operation) or air recirculation ensures rated performance, reliable operation, and ease of maintenance. Site restrictions may compromise minimum clearances indicated below, resulting in unpredictable air patterns and possible diminished performance. Johnson Controls' unit controls will optimize the operation without nuisance high pressure safety cutouts; however, the system designer **MUST** consider potential performance degradation.

Access to the unit control center stipulates the unit is no higher than on spring isolators. Recommended minimum clearances: side to wall - 2m; rear to wall - 2m; control panel end to wall - 1.2m; top - no obstructions whatsoever; distance between adjacent units - 10'. No more than one adjacent wall may be higher than the unit.

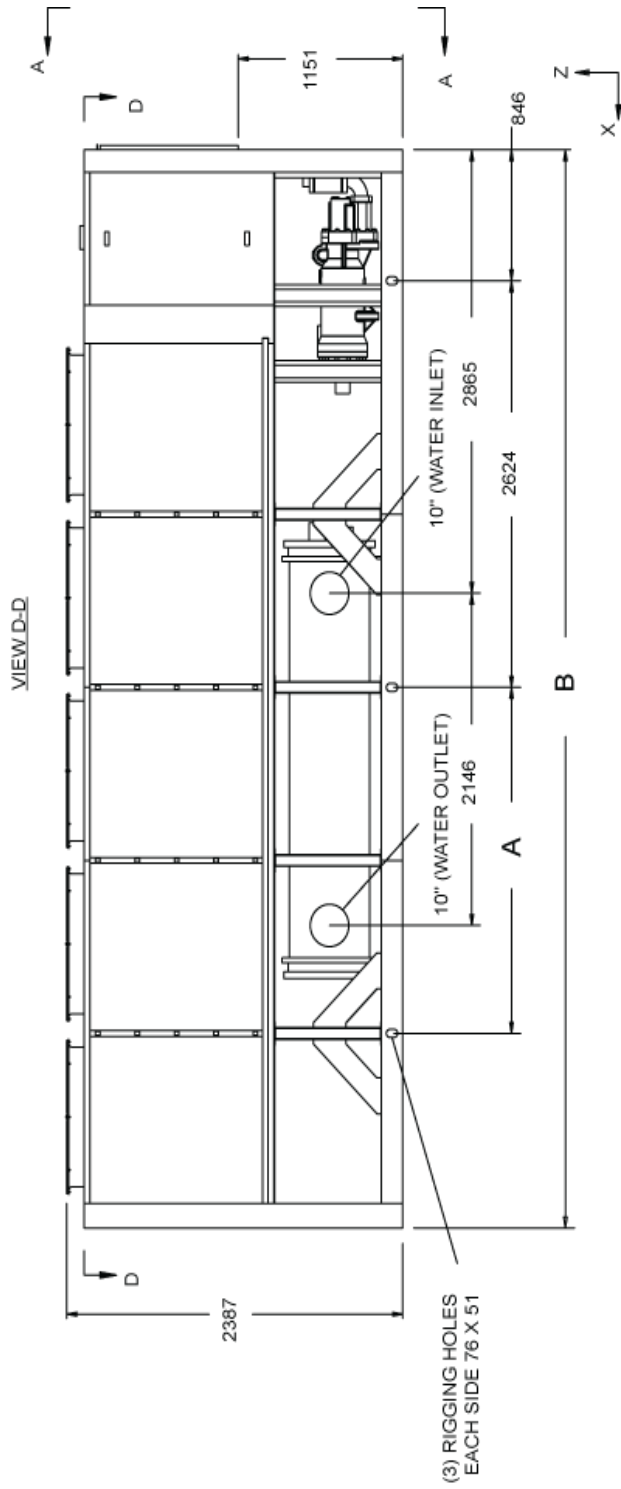
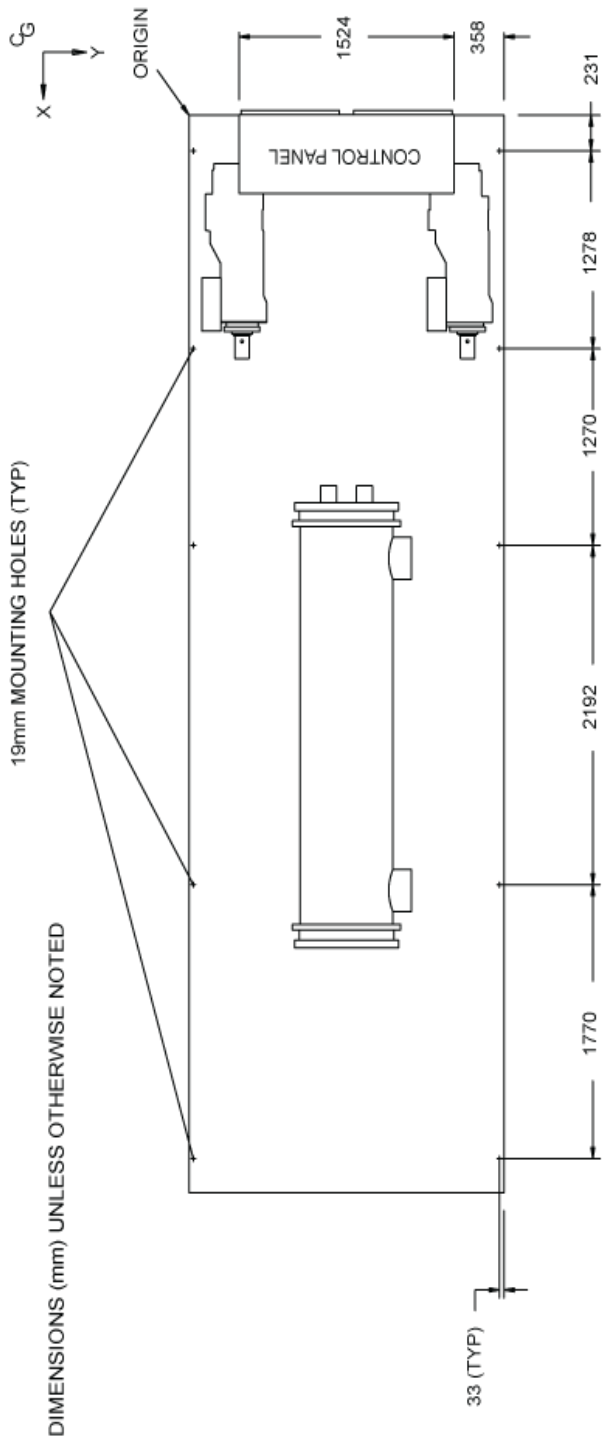

## YCIV0760E/V, YCIV0770S/P, and YCIV0890S/P

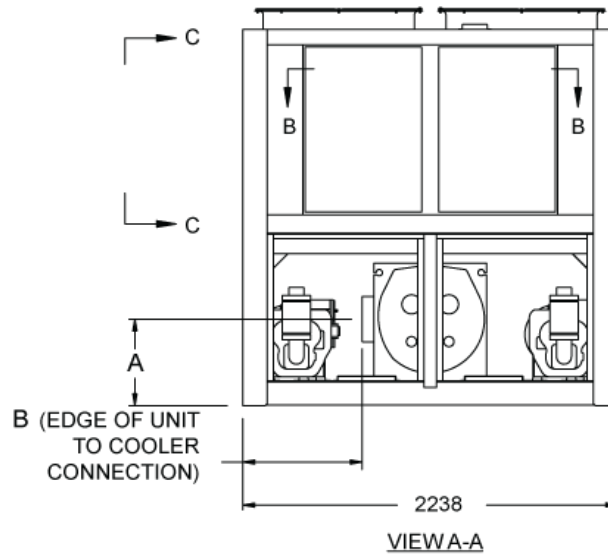
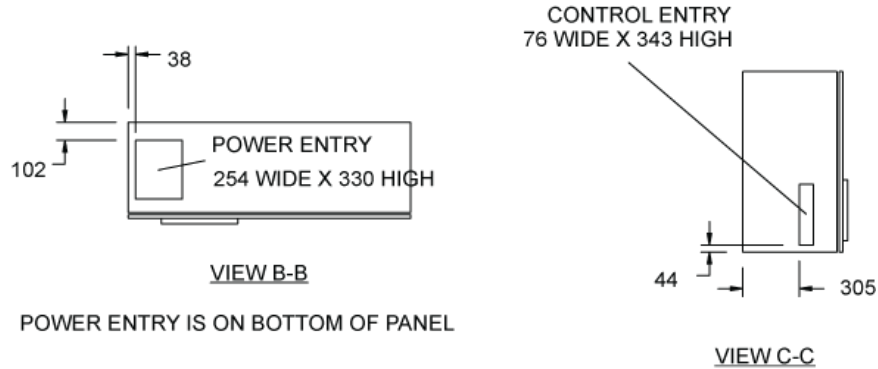

YCIV	A	B	C	D
0760E/V	518	714	2174	2852
0770S/P	564	660	2009	2878
0890S/P	564	660	2009	2878

**Notes:**

1. Placement on a level surface free of obstructions (including snow, for winter operation) or air recirculation ensures rated performance, reliable operation, and ease of maintenance. Site restrictions may compromise minimum clearances indicated below, resulting in unpredictable air patterns and possible diminished performance. Johnson Controls' unit controls will optimize the operation without nuisance high pressure safety cutouts; however, the system designer **MUST** consider potential performance degradation.

Access to the unit control center stipulates the unit is no higher than on spring isolators. Recommended minimum clearances: side to wall - 2m; rear to wall - 2m; control panel end to wall - 1.2m; top - no obstructions whatsoever; distance between adjacent units - 10'. No more than one adjacent wall may be higher than the unit.

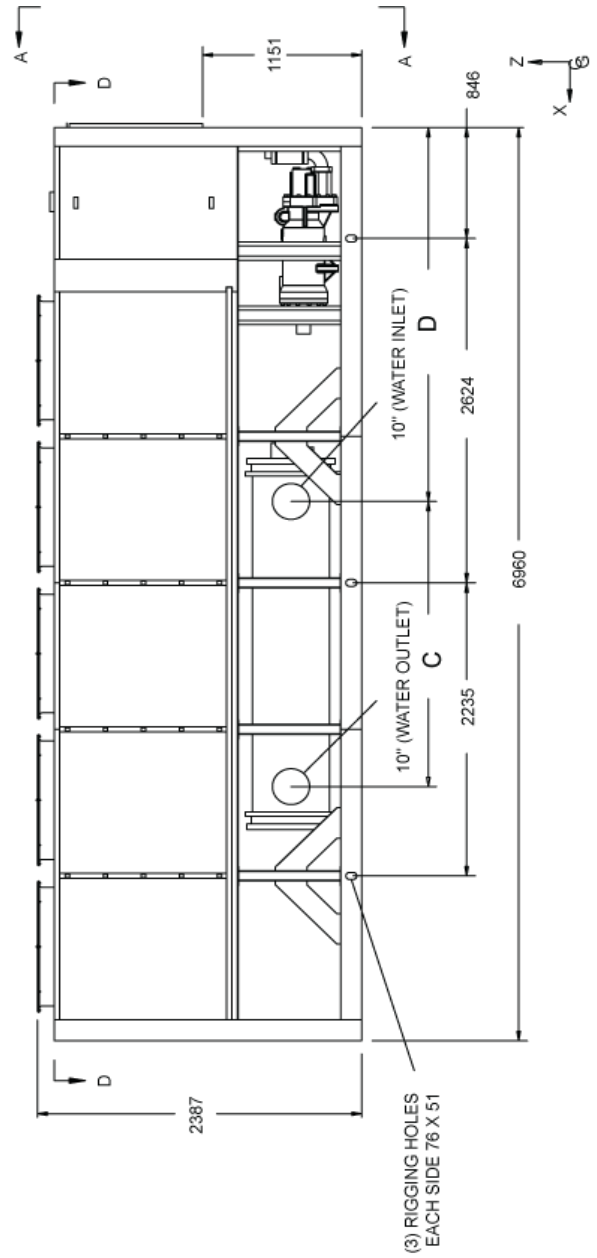
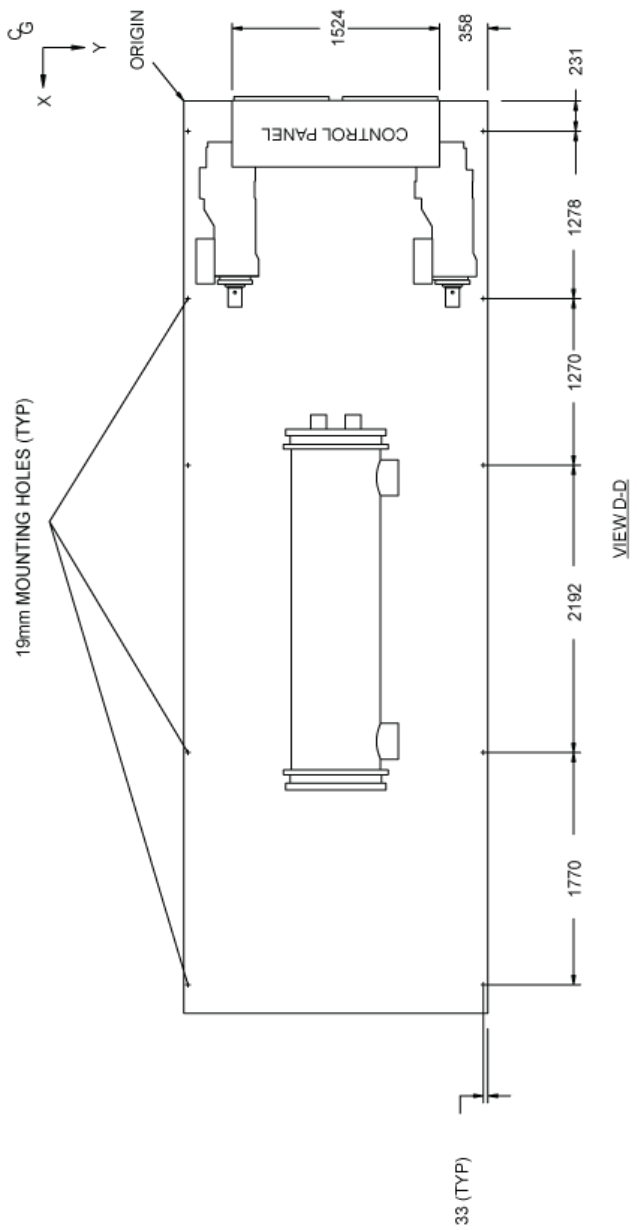

## YCIV0800E/V and YCIV0830E/V

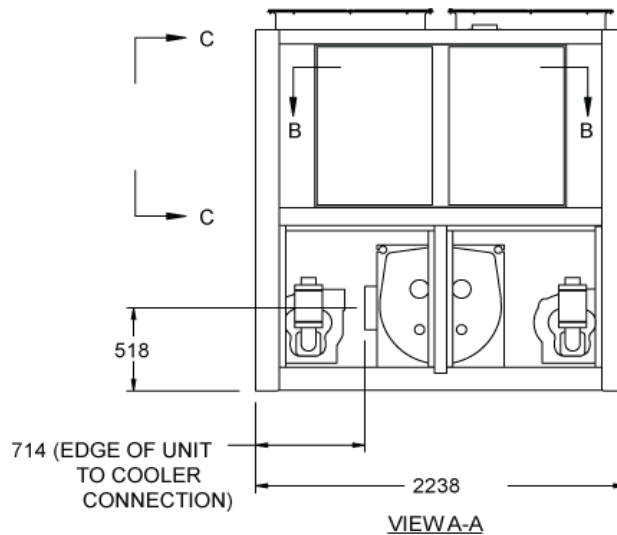
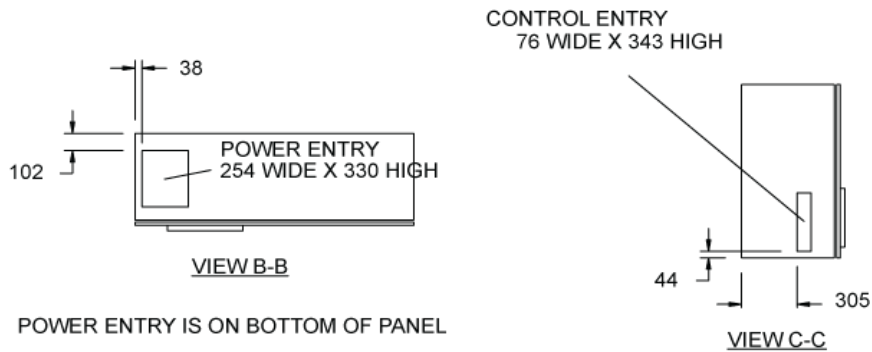

**Notes:**

1. Placement on a level surface free of obstructions (including snow, for winter operation) or air recirculation ensures rated performance, reliable operation, and ease of maintenance. Site restrictions may compromise minimum clearances indicated below, resulting in unpredictable air patterns and possible diminished performance. Johnson Controls' unit controls will optimize the operation without nuisance high pressure safety cutouts; however, the system designer **MUST** consider potential performance degradation.

Access to the unit control center stipulates the unit is no higher than on spring isolators. Recommended minimum clearances: side to wall - 2m; rear to wall - 2m; control panel end to wall - 1.2m; top - no obstructions whatsoever; distance between adjacent units - 10'. No more than one adjacent wall may be higher than the unit.



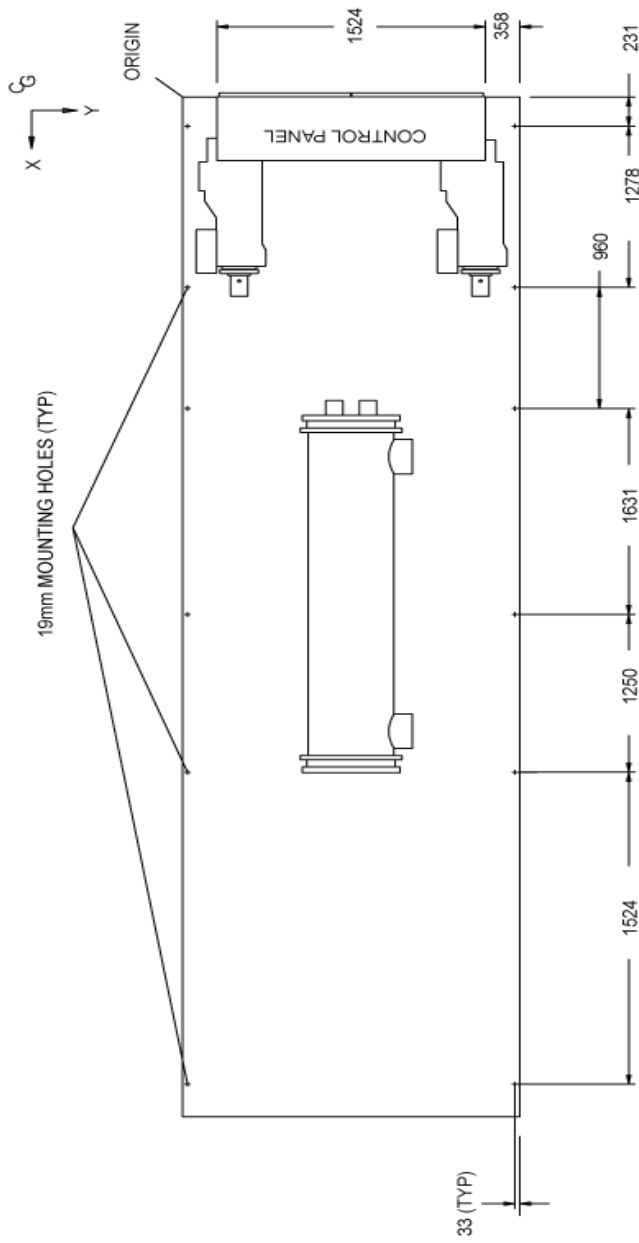

VIEW D-D

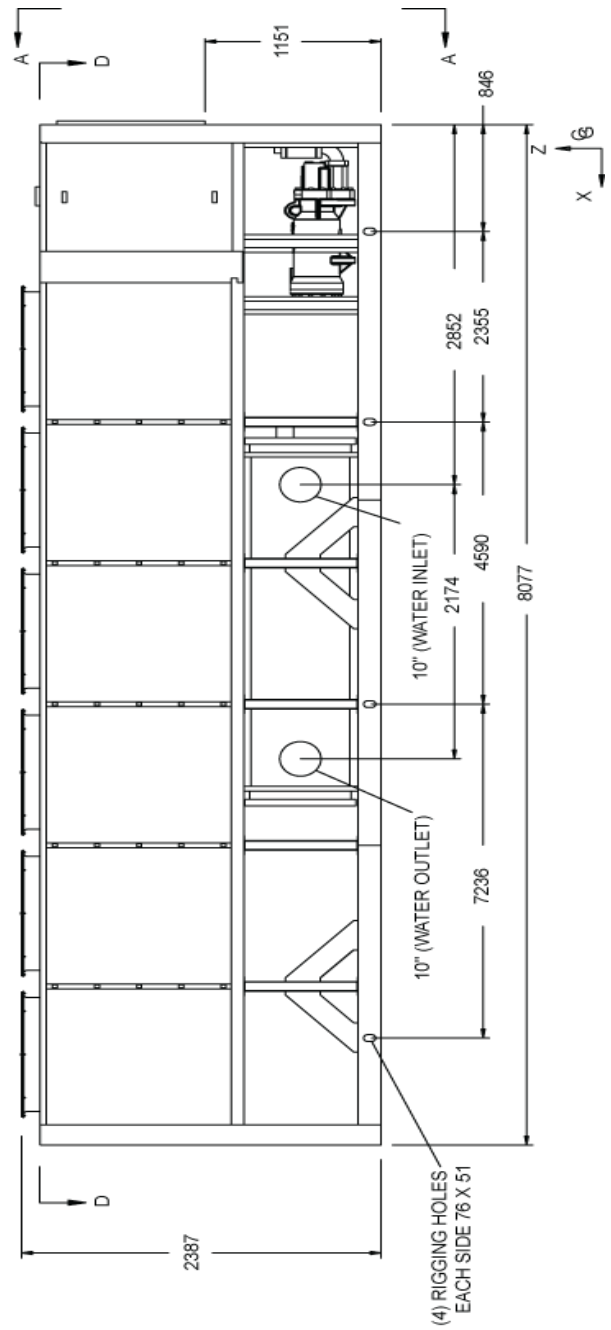

## YCIV0920S/P, YCIV0930E/V, and YCIV1000S/P

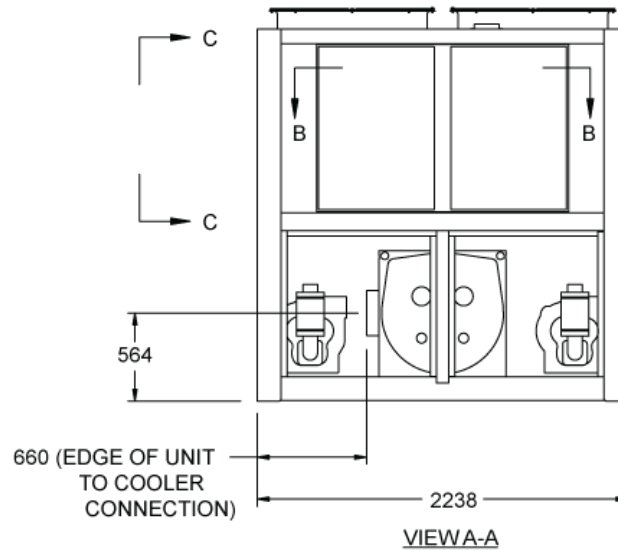
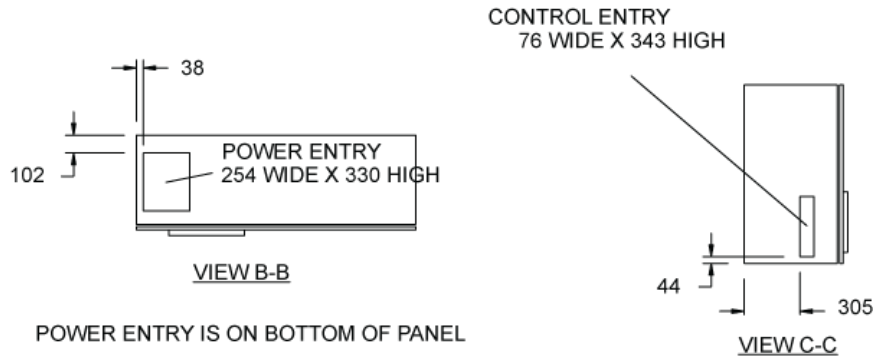

**Notes:**

1. Placement on a level surface free of obstructions (including snow, for winter operation) or air recirculation ensures rated performance, reliable operation, and ease of maintenance. Site restrictions may compromise minimum clearances indicated below, resulting in unpredictable air patterns and possible diminished performance. Johnson Controls' unit controls will optimize the operation without nuisance high pressure safety cutouts; however, the system designer **MUST** consider potential performance degradation.

Access to the unit control center stipulates the unit is no higher than on spring isolators. Recommended minimum clearances: side to wall - 2m; rear to wall - 2m; control panel end to wall - 1.2m; top - no obstructions whatsoever; distance between adjacent units - 10'. No more than one adjacent wall may be higher than the unit.

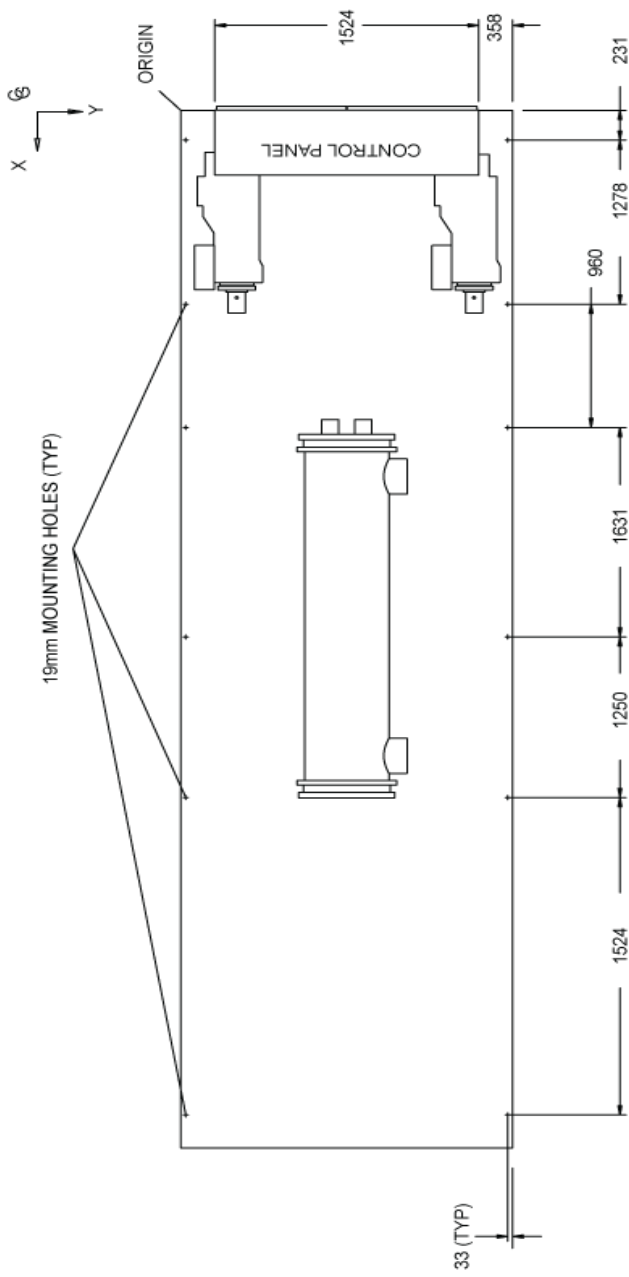

VIEW D-D

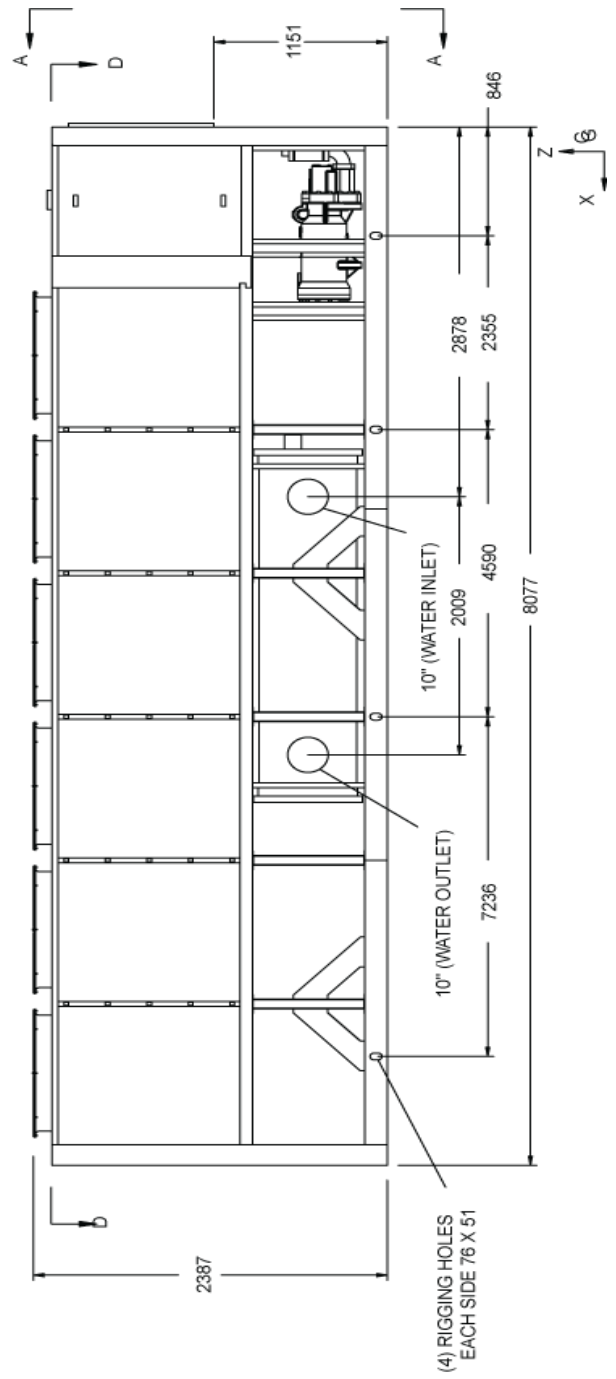

## YCIV1050E/V and YCIV1070S/P

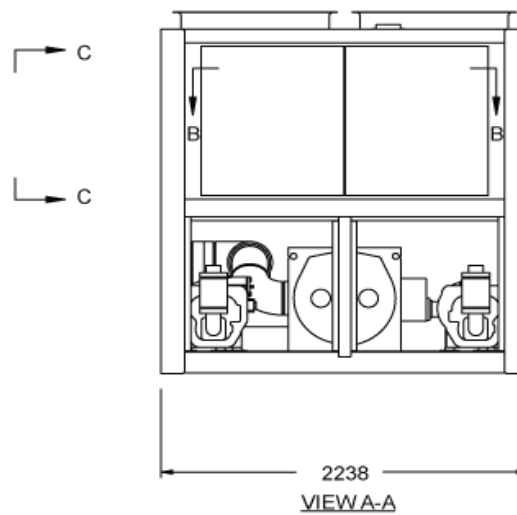
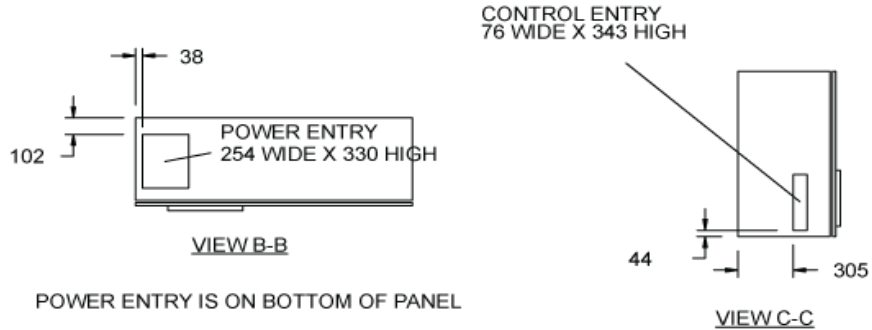

**Notes:**

1. Placement on a level surface free of obstructions (including snow, for winter operation) or air recirculation ensures rated performance, reliable operation, and ease of maintenance. Site restrictions may compromise minimum clearances indicated below, resulting in unpredictable air patterns and possible diminished performance. Johnson Controls' unit controls will optimize the operation without nuisance high pressure safety cutouts; however, the system designer **MUST** consider potential performance degradation.

Access to the unit control center stipulates the unit is no higher than on spring isolators. Recommended minimum clearances: side to wall - 2m; rear to wall - 2m; control panel end to wall - 1.2m; top - no obstructions whatsoever; distance between adjacent units - 10'. No more than one adjacent wall may be higher than the unit.

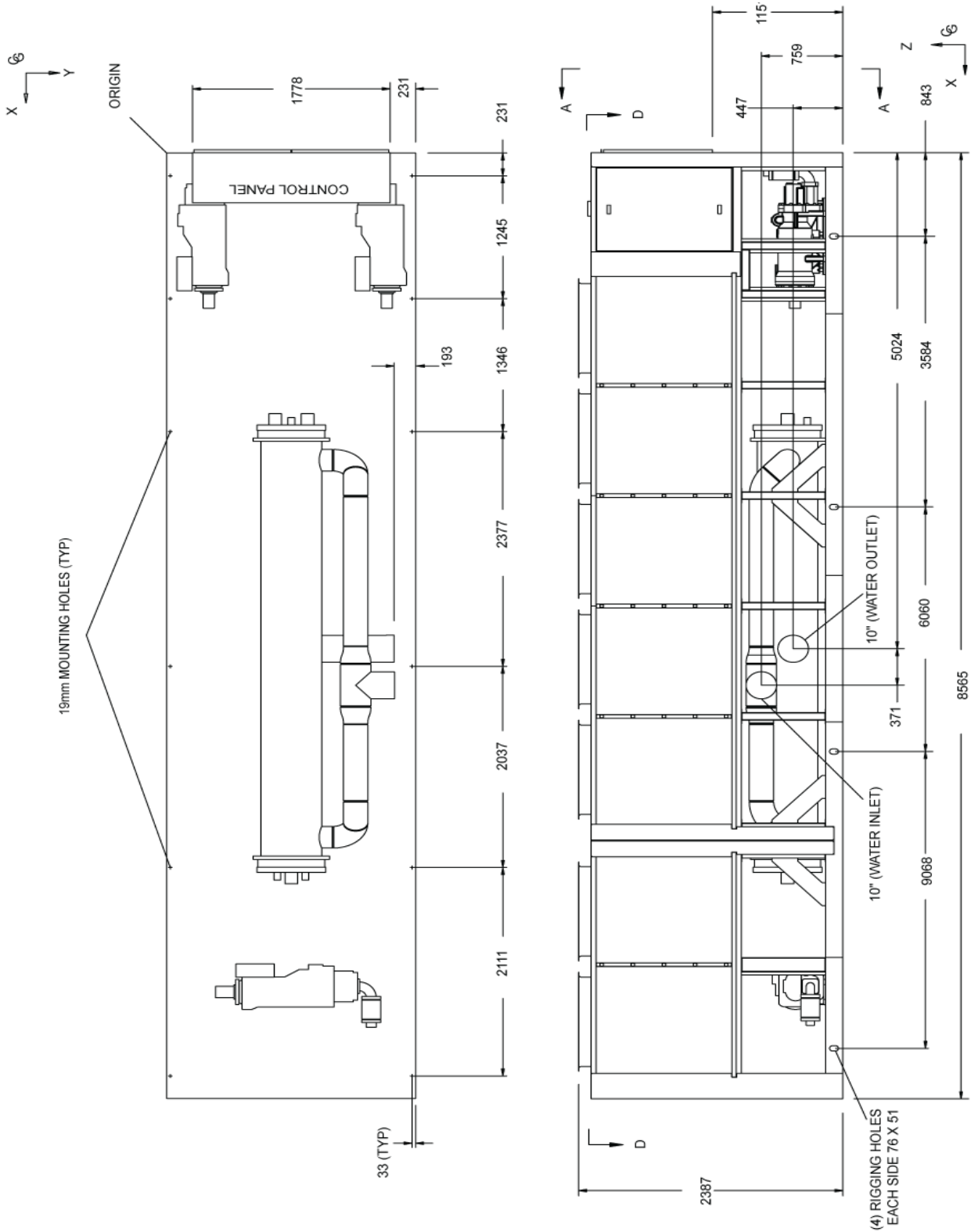

## YCIV1120E/V

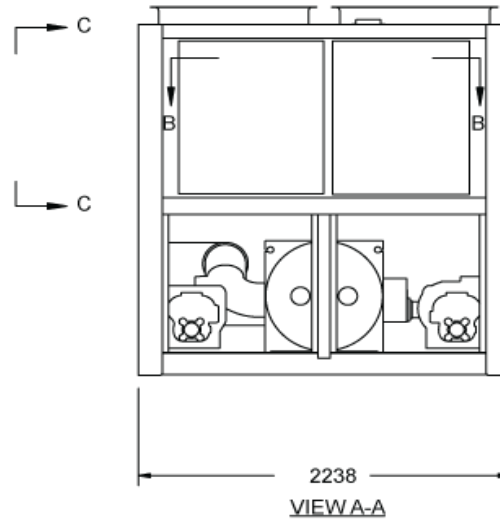
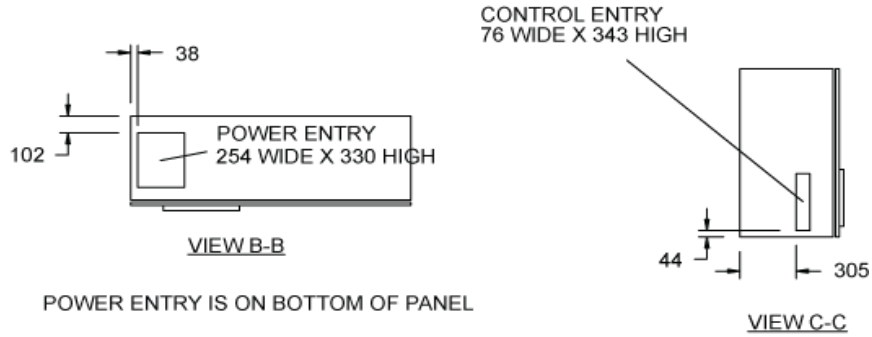

**Notes:**

1. Placement on a level surface free of obstructions (including snow, for winter operation) or air recirculation ensures rated performance, reliable operation, and ease of maintenance. Site restrictions may compromise minimum clearances indicated below, resulting in unpredictable air patterns and possible diminished performance. Johnson Controls' unit controls will optimize the operation without nuisance high pressure safety cutouts; however, the system designer **MUST** consider potential performance degradation.

Access to the unit control center stipulates the unit is no higher than on spring isolators. Recommended minimum clearances: side to wall - 2m; rear to wall - 2m; control panel end to wall - 1.2m; top - no obstructions whatsoever; distance between adjacent units - 10'. No more than one adjacent wall may be higher than the unit.

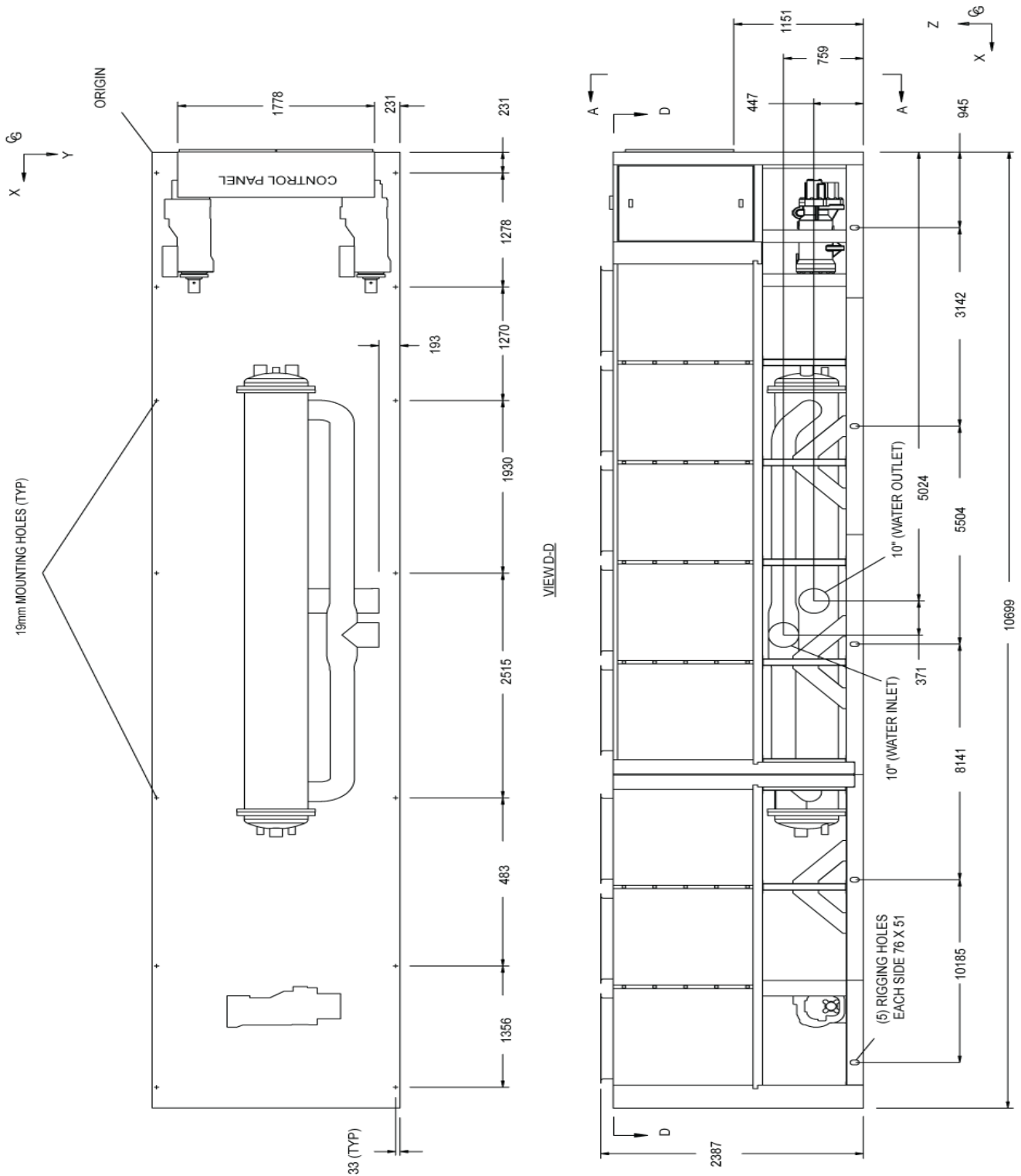

## YCIV1180S/P

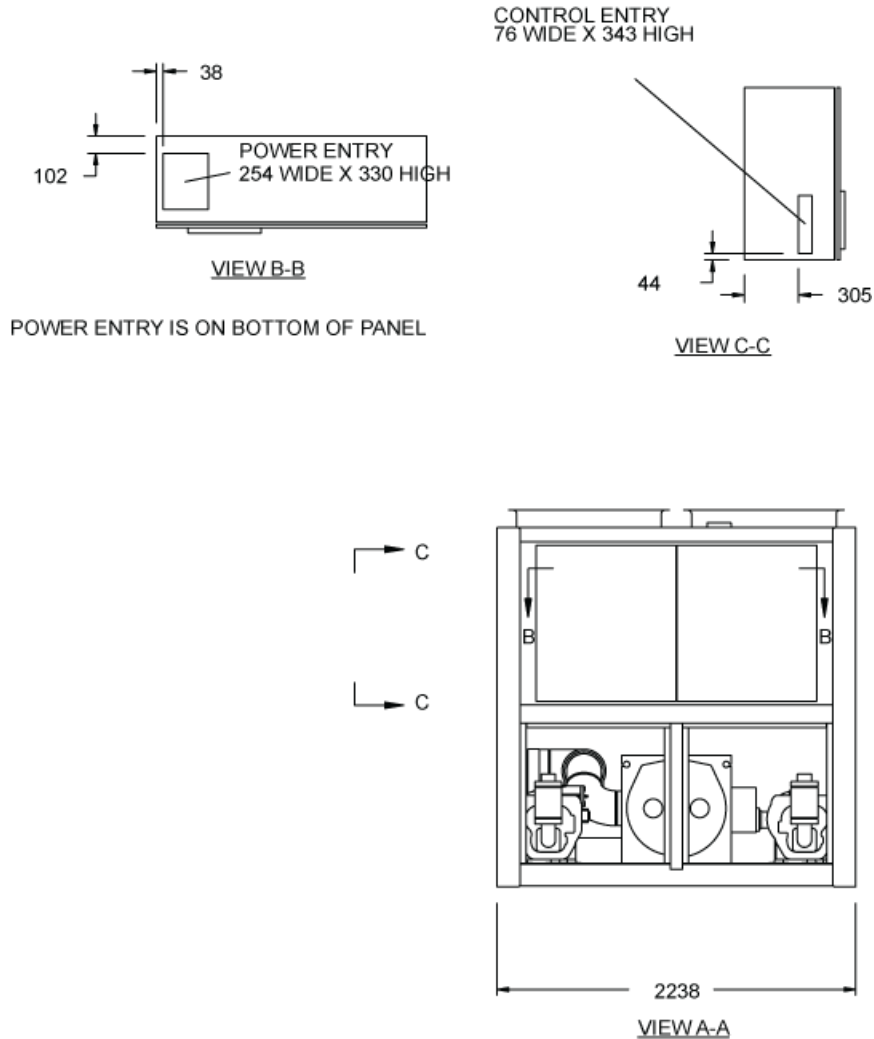

**Notes:**

1. Placement on a level surface free of obstructions (including snow, for winter operation) or air recirculation ensures rated performance, reliable operation, and ease of maintenance. Site restrictions may compromise minimum clearances indicated below, resulting in unpredictable air patterns and possible diminished performance. Johnson Controls' unit controls will optimize the operation without nuisance high pressure safety cutouts; however, the system designer **MUST** consider potential performance degradation.

Access to the unit control center stipulates the unit is no higher than on spring isolators. Recommended minimum clearances: side to wall - 2m; rear to wall - 2m; control panel end to wall - 1.2m; top - no obstructions whatsoever; distance between adjacent units - 10'. No more than one adjacent wall may be higher than the unit.



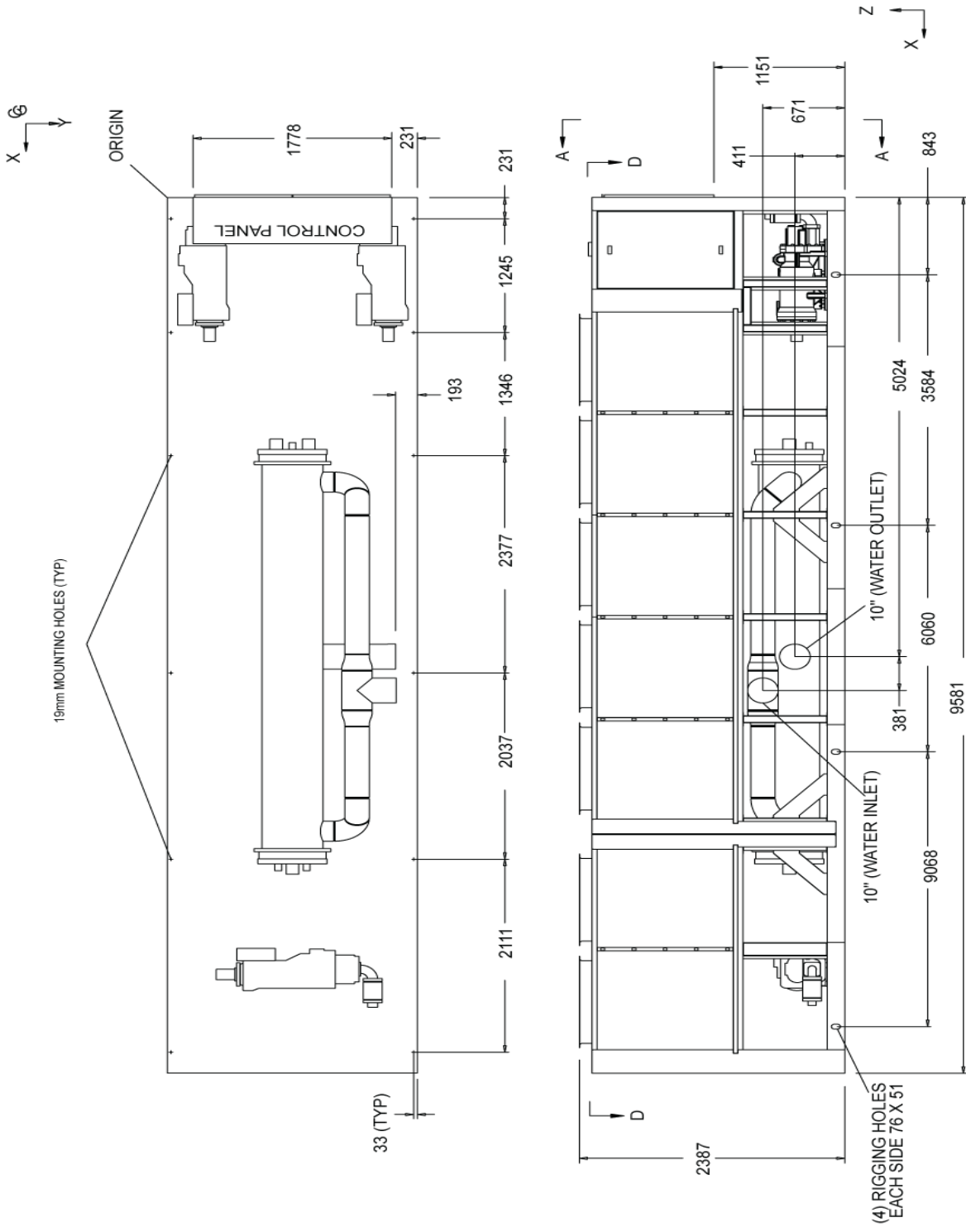

## YCIV1220E/V and YCIV1340S/P

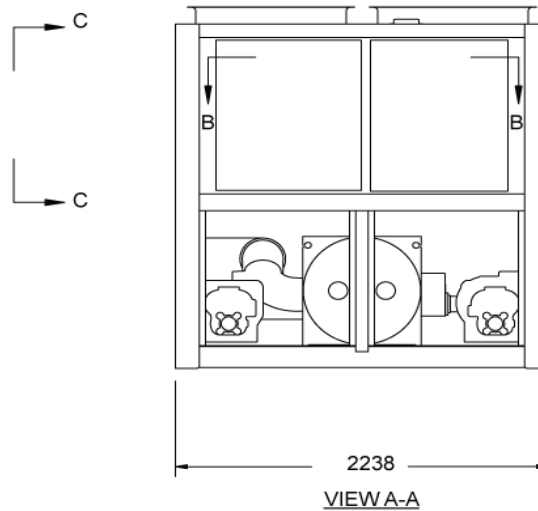
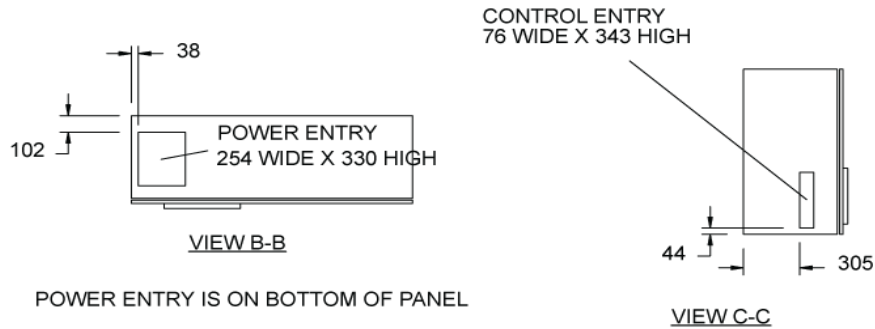

**Notes:**

1. Placement on a level surface free of obstructions (including snow, for winter operation) or air recirculation ensures rated performance, reliable operation, and ease of maintenance. Site restrictions may compromise minimum clearances indicated below, resulting in unpredictable air patterns and possible diminished performance. Johnson Controls' unit controls will optimize the operation without nuisance high pressure safety cutouts; however, the system designer **MUST** consider potential performance degradation.

Access to the unit control center stipulates the unit is no higher than on spring isolators. Recommended minimum clearances: side to wall - 2m; rear to wall - 2m; control panel end to wall - 1.2m; top - no obstructions whatsoever; distance between adjacent units - 10'. No more than one adjacent wall may be higher than the unit.

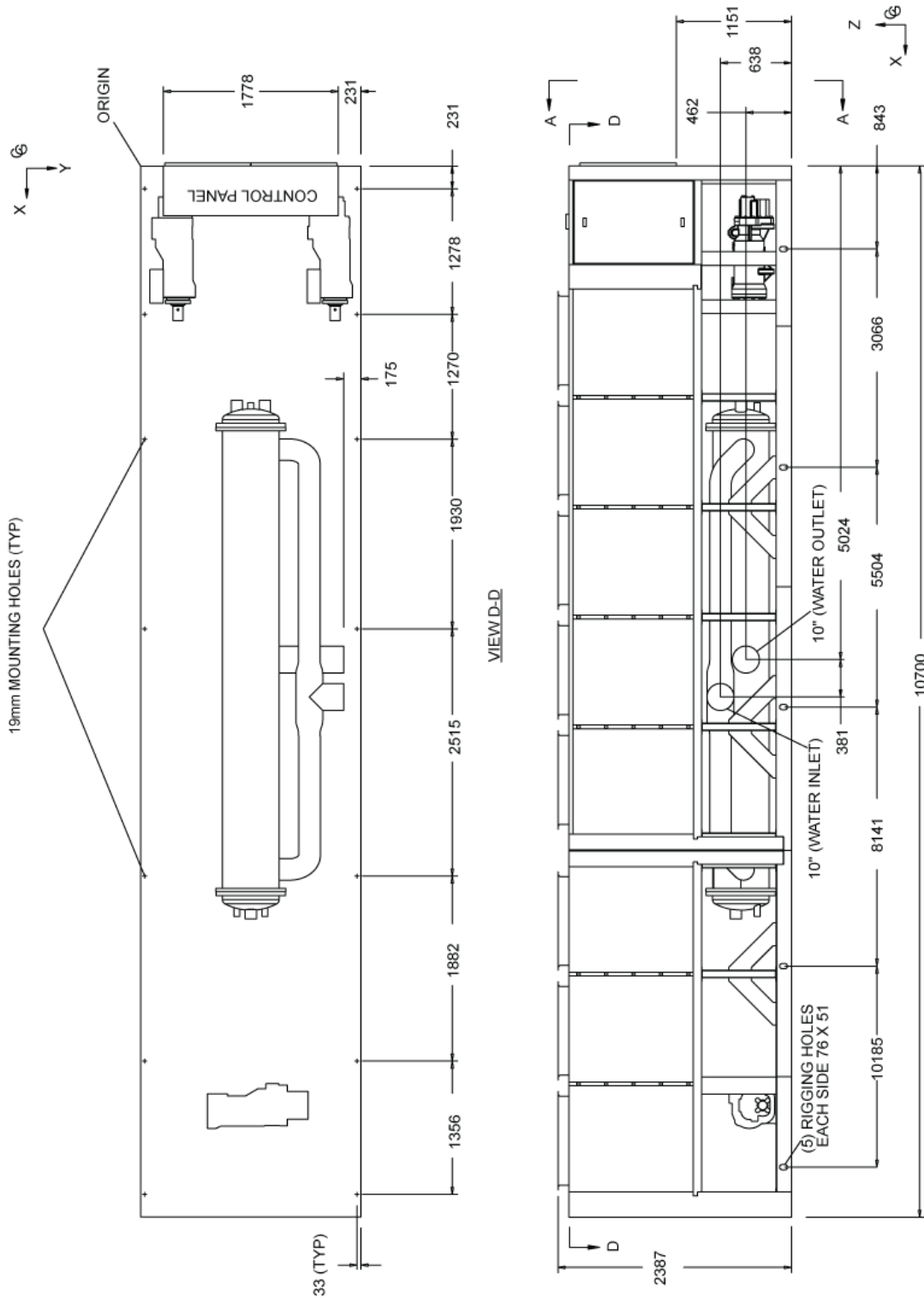

## YCIV1380E/V and YCIV1500S/P

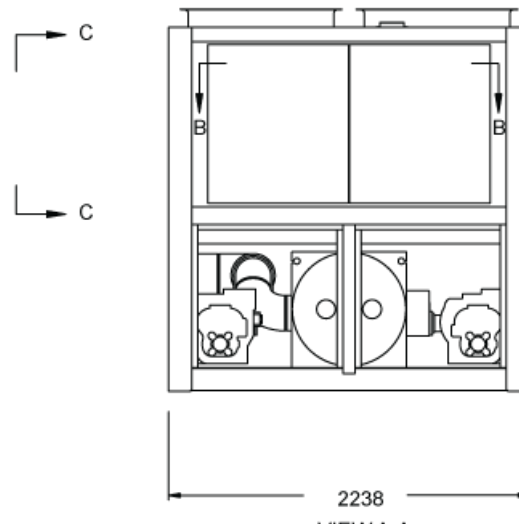
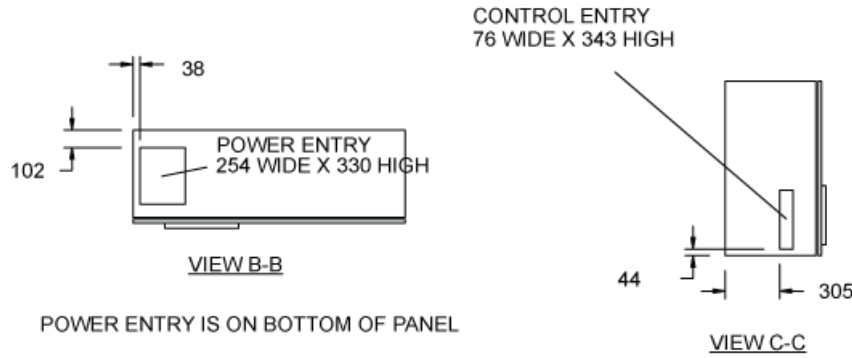

**Notes:**

1. Placement on a level surface free of obstructions (including snow, for winter operation) or air recirculation ensures rated performance, reliable operation, and ease of maintenance. Site restrictions may compromise minimum clearances indicated below, resulting in unpredictable air patterns and possible diminished performance. Johnson Controls' unit controls will optimize the operation without nuisance high pressure safety cutouts; however, the system designer **MUST** consider potential performance degradation.

Access to the unit control center stipulates the unit is no higher than on spring isolators. Recommended minimum clearances: side to wall - 2m; rear to wall - 2m; control panel end to wall - 1.2m; top - no obstructions whatsoever; distance between adjacent units - 10'. No more than one adjacent wall may be higher than the unit.

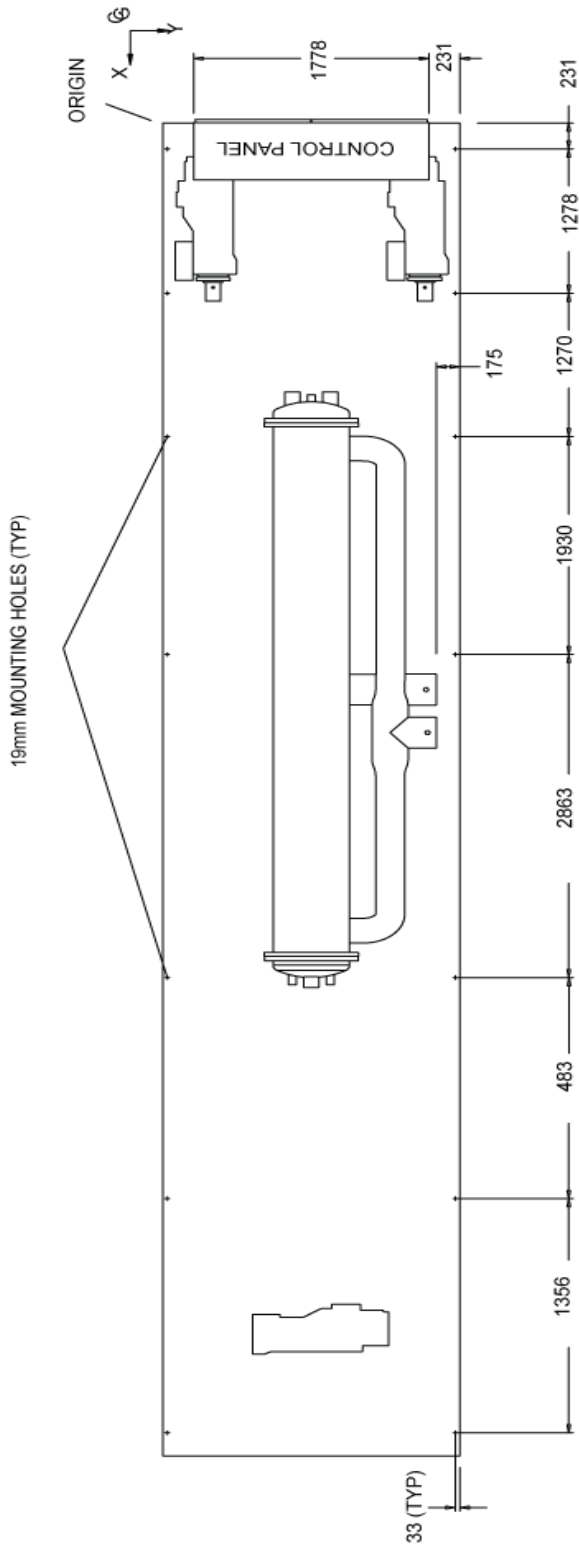

VIEW D-D

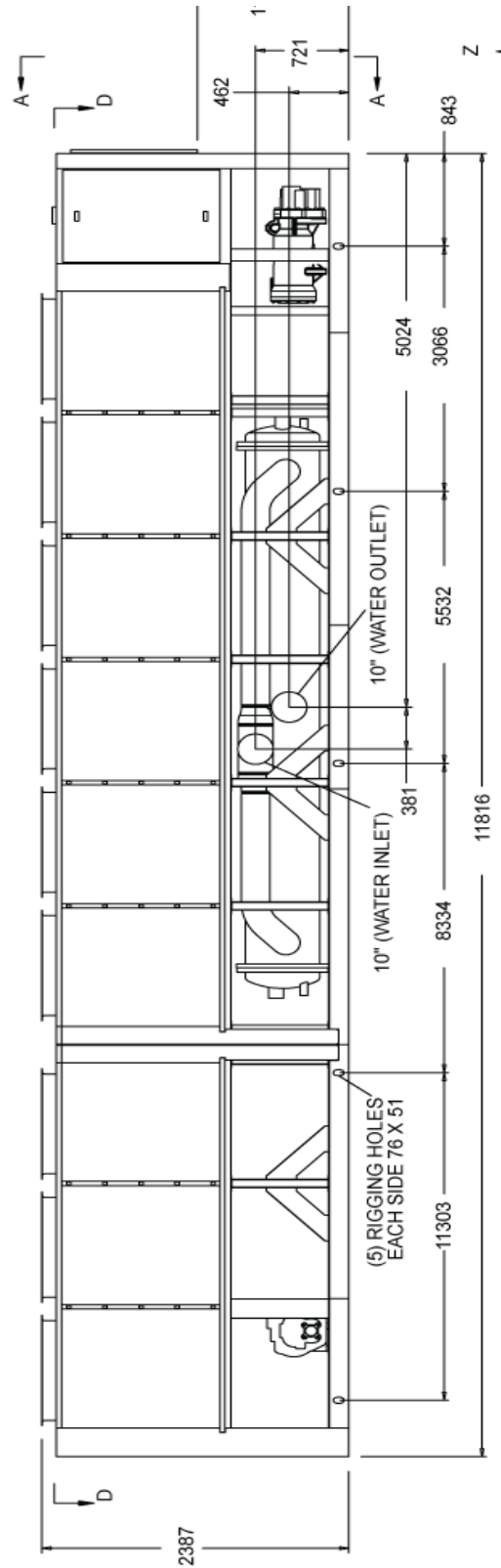

## Models YCIV1649P

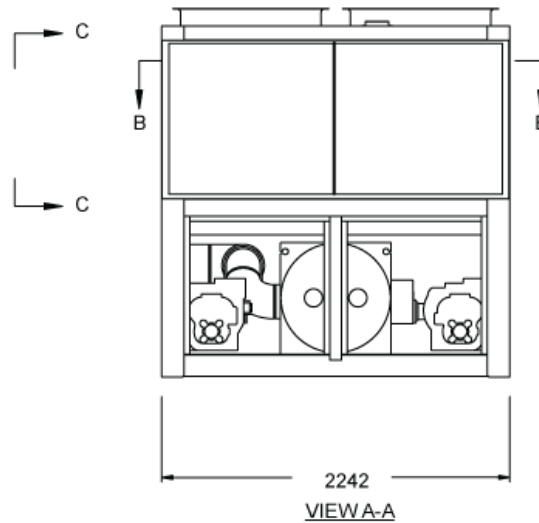
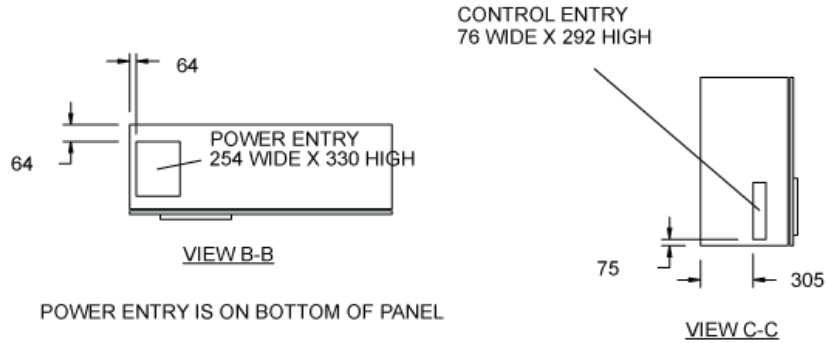

**Notes:**

1. Placement on a level surface free of obstructions (including snow, for winter operation) or air recirculation ensures rated performance, reliable operation, and ease of maintenance. Site restrictions may compromise minimum clearances indicated below, resulting in unpredictable air patterns and possible diminished performance. Johnson Controls' unit controls will optimize the operation without nuisance high pressure safety cutouts; however, the system designer **MUST** consider potential performance degradation.

Access to the unit control center stipulates the unit is no higher than on spring isolators. Recommended minimum clearances: side to wall - 2m; rear to wall - 2m; control panel end to wall - 1.2m; top - no obstructions whatsoever; distance between adjacent units - 10'. No more than one adjacent wall may be higher than the unit.

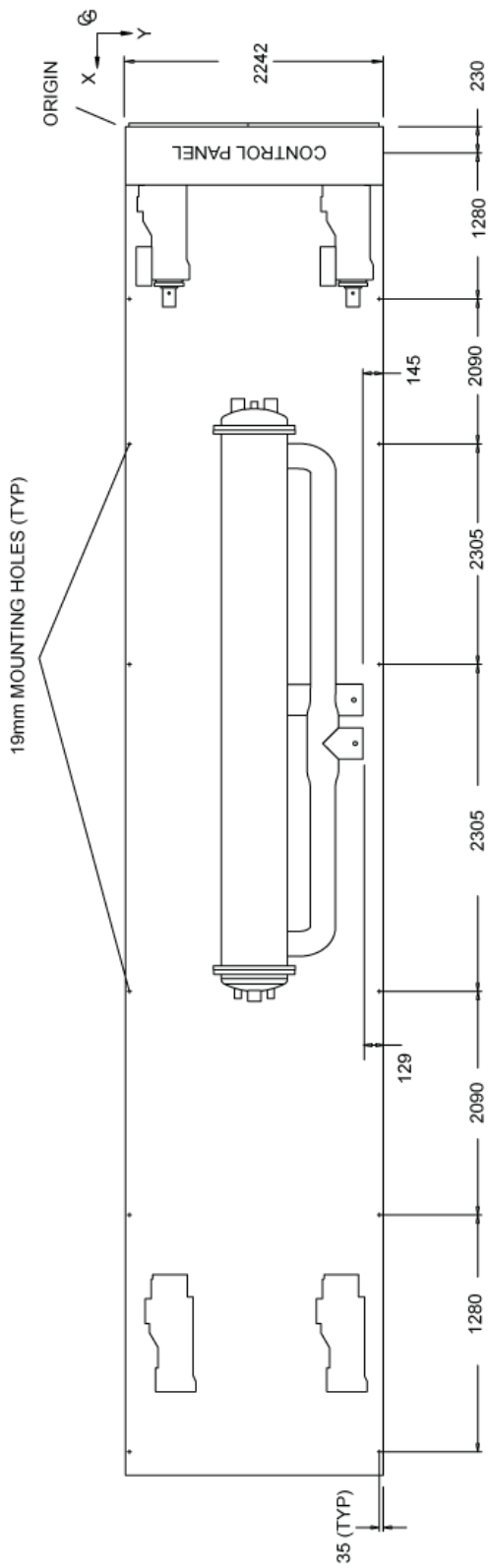

VIEW D-D

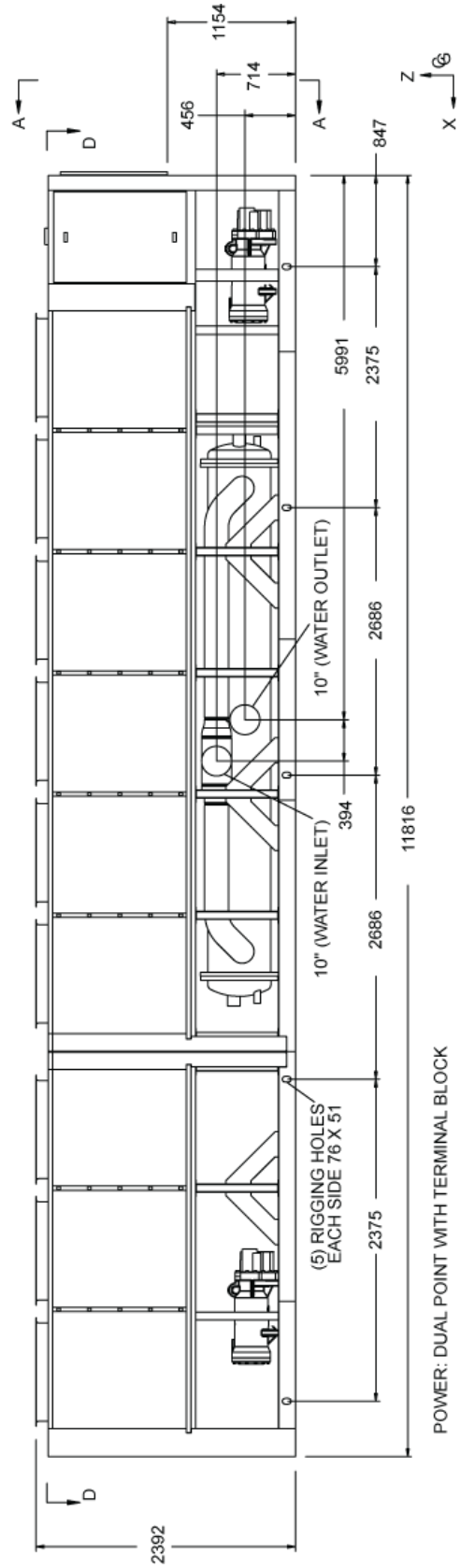

# Isolator Locations

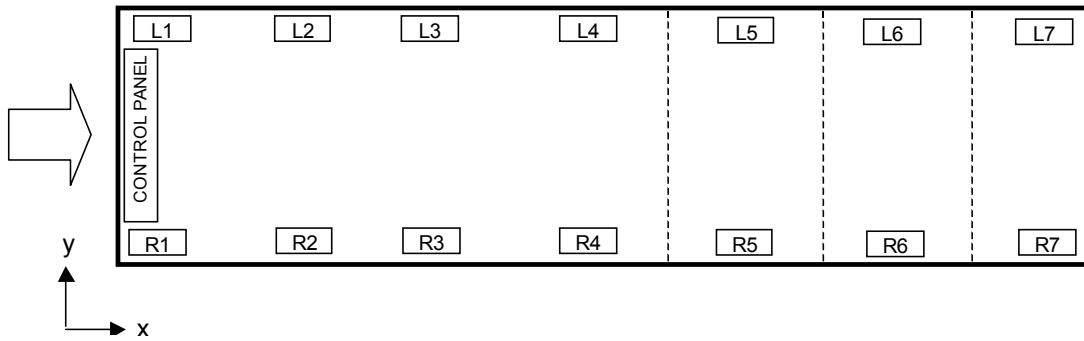

STANDARD EFFICIENCY - SI								
MODEL YCIV	ISOLATOR LOCATIONS ( X , Y ) - MM AND POINT LOADS - KG							
50 HZ		1	2	3	4	5	6	7
0600S/P	LEFT - L	( 230 , 2204 )	( 1510 , 2204 )	( 2780 , 2204 )	( 5360 , 2204 )			
	AL FIN COILS	772	722	633	608			
	CU FIN COILS	772	773	789	763			
	RS&LS1 / AL FIN COILS	853	803	633	608			
	RS&LS1 / CU FIN COILS	853	854	789	763			
	RIGHT - R	( 230 , 32 )	( 1510 , 32 )	( 2780 , 32 )	( 5360 , 32 )			
	AL FIN COILS	772	722	633	608			
	CU FIN COILS	772	773	789	763			
0650S/P	LEFT - L	( 230 , 2204 )	( 1510 , 2204 )	( 2780 , 2204 )	( 5360 , 2204 )			
	AL FIN COILS	780	732	756	730			
	CU FIN COILS	780	783	912	885			
	RS&LS1 / AL FIN COILS	861	813	756	730			
	RS&LS1 / CU FIN COILS	861	864	912	885			
	RIGHT - R	( 230 , 32 )	( 1510 , 32 )	( 2780 , 32 )	( 5360 , 32 )			
	AL FIN COILS	772	723	756	730			
	CU FIN COILS	772	774	912	885			
0720S/P	LEFT - L	( 230 , 2204 )	( 1510 , 2204 )	( 2780 , 2204 )	( 4970 , 2204 )	( 6740 , 2204 )		
	AL FIN COILS	778	716	707	578	351		
	CU FIN COILS	778	771	861	750	424		
	RS&LS1 / AL FIN COILS	859	797	707	578	351		
	RS&LS1 / CU FIN COILS	859	852	861	750	424		
	RIGHT - R	( 230 , 32 )	( 1510 , 32 )	( 2780 , 32 )	( 4970 , 32 )	( 6740 , 32 )		
	AL FIN COILS	770	707	707	563	301		
	CU FIN COILS	770	762	861	735	374		
0770S/P	LEFT - L	( 230 , 2204 )	( 1510 , 2204 )	( 2780 , 2204 )	( 4970 , 2204 )	( 6740 , 2204 )		
	AL FIN COILS	784	762	802	686	415		
	CU FIN COILS	784	817	956	858	488		
	RS&LS1 / AL FIN COILS	865	843	802	686	415		
	RS&LS1 / CU FIN COILS	865	898	956	858	488		
	RIGHT - R	( 230 , 32 )	( 1510 , 32 )	( 2780 , 32 )	( 4970 , 32 )	( 6740 , 32 )		
	AL FIN COILS	784	760	800	669	363		
	CU FIN COILS	784	815	956	841	436		
0840S/P	LEFT - L	( 230 , 2204 )	( 1510 , 2204 )	( 2780 , 2204 )	( 4970 , 2204 )	( 6740 , 2204 )		
	AL FIN COILS	784	762	802	691	435		
	CU FIN COILS	784	817	956	863	508		
	RS&LS1 / AL FIN COILS	865	843	802	691	435		
	RS&LS1 / CU FIN COILS	865	898	956	863	508		
	RIGHT - R	( 230 , 32 )	( 1510 , 32 )	( 2780 , 32 )	( 4970 , 32 )	( 6740 , 32 )		
	AL FIN COILS	784	760	800	689	433		
	CU FIN COILS	784	815	954	861	506		
0840S/P	RS&LS1 / AL FIN COILS	865	841	800	689	433		
	RS&LS1 / CU FIN COILS	865	896	954	861	506		



STANDARD EFFICIENCY - SI								
MODEL YCIV	ISOLATOR LOCATIONS ( X , Y ) - MM AND POINT LOADS - KG							
50 HZ		1	2	3	4	5	6	7
0920S/P	LEFT - L	( 230 , 2204 )	( 1510 , 2204 )	( 2470 , 2204 )	( 4100 , 2204 )	( 5350 , 2204 )	( 7820 , 2204 )	
	AL FIN COILS	784	743	566	526	572	435	
	CU FIN COILS	784	784	675	651	730	544	
	RS&LS1 / AL FIN COILS	865	824	566	526	572	435	
	RS&LS1 / CU FIN COILS	865	865	675	651	730	544	
	RIGHT - R	( 230 , 32 )	( 1510 , 32 )	( 2470 , 32 )	( 4100 , 32 )	( 5350 , 32 )	( 7820 , 32 )	
	AL FIN COILS	780	737	562	523	561	433	
	CU FIN COILS	780	778	671	648	719	542	
	RS&LS1 / AL FIN COILS	861	818	562	523	561	433	
RS&LS1 / CU FIN COILS	861	859	671	648	721	542		
1000S/P	LEFT - L	( 230 , 2204 )	( 1510 , 2204 )	( 2470 , 2204 )	( 4100 , 2204 )	( 5350 , 2204 )	( 7820 , 2204 )	
	AL FIN COILS	784	743	566	526	574	456	
	CU FIN COILS	784	784	675	651	732	565	
	RS&LS1 / AL FIN COILS	865	824	566	526	574	456	
	RS&LS1 / CU FIN COILS	865	865	675	651	732	565	
	RIGHT - R	( 230 , 32 )	( 1510 , 32 )	( 2470 , 32 )	( 4100 , 32 )	( 5350 , 32 )	( 7820 , 32 )	
	AL FIN COILS	784	743	566	526	574	456	
	CU FIN COILS	784	784	675	651	732	565	
	RS&LS1 / AL FIN COILS	865	824	566	526	574	456	
RS&LS1 / CU FIN COILS	865	865	675	651	734	565		
1070S/P	LEFT - L	( 230 , 2204 )	( 1475 , 2204 )	( 2823 , 2204 )	( 5199 , 2204 )	( 7236 , 2204 )	( 9346 , 2204 )	
	AL FIN COILS	795	719	826	821	963	533	
	CU FIN COILS	805	797	982	978	1119	611	
	RS&LS1 / AL FIN COILS	875	799	826	821	993	663	
	RS&LS1 / CU FIN COILS	855	877	982	978	1149	741	
	RIGHT - R	( 230 , 32 )	( 1475 , 32 )	( 2823 , 32 )	( 5199 , 32 )	( 7236 , 32 )	( 9346 , 32 )	
	AL FIN COILS	795	724	1092	1095	1195	535	
	CU FIN COILS	805	802	1248	1252	1351	613	
	RS&LS1 / AL FIN COILS	875	804	1092	1095	1225	665	
RS&LS1 / CU FIN COILS	885	882	1248	1252	1381	743		
1180S/P	LEFT - L	( 230 , 2204 )	( 1475 , 2204 )	( 2823 , 2204 )	( 5199 , 2204 )	( 7236 , 2204 )	( 9346 , 2204 )	
	AL FIN COILS	795	719	886	897	1045	537	
	CU FIN COILS	805	797	1042	1054	1201	615	
	RS&LS1 / AL FIN COILS	875	799	886	897	1075	667	
	RS&LS1 / CU FIN COILS	885	877	1042	1054	1231	745	
	RIGHT - R	( 230 , 32 )	( 1475 , 32 )	( 2823 , 32 )	( 5199 , 32 )	( 7236 , 32 )	( 9346 , 32 )	
	AL FIN COILS	795	724	1152	1194	1314	539	
	CU FIN COILS	805	802	1308	1351	1470	607	
	RS&LS1 / AL FIN COILS	875	804	1152	1194	1344	669	
RS&LS1 / CU FIN COILS	885	882	1308	1351	1500	747		
1340S/P	LEFT - L	( 230 , 2204 )	( 1510 , 2204 )	( 2780 , 2204 )	( 4710 , 2204 )	( 7225 , 2204 )	( 9105 , 2204 )	( 10463 , 2204 )
	AL FIN COILS	795	719	886	897	886	517	429
	CU FIN COILS	805	786	1015	1072	1061	646	483
	RS&LS1 / AL FIN COILS	875	799	886	897	886	597	509
	RS&LS1 / CU FIN COILS	885	866	1015	1072	1061	726	563
	RIGHT - R	( 230 , 32 )	( 1510 , 32 )	( 2780 , 32 )	( 4710 , 32 )	( 7225 , 32 )	( 9105 , 32 )	( 10463 , 32 )
	AL FIN COILS	795	724	1152	1194	1152	522	429
	CU FIN COILS	805	778	1281	1369	1327	651	483
	RS&LS1 / AL FIN COILS	875	804	1152	1194	1152	602	509
RS&LS1 / CU FIN COILS	885	858	1281	1369	1327	731	563	
1500S/P	LEFT - L	( 230 , 2204 )	( 1510 , 2204 )	( 2780 , 2204 )	( 4710 , 2204 )	( 7572 , 2204 )	( 9530 , 2204 )	( 11582 , 2204 )
	AL FIN COILS	801	729	886	897	926	637	479
	CU FIN COILS	811	796	1015	1072	1101	766	533
	RS&LS1 / AL FIN COILS	881	809	886	897	926	717	559
	RS&LS1 / CU FIN COILS	891	876	1015	1072	1101	846	613
	RIGHT - R	( 230 , 32 )	( 1510 , 32 )	( 2780 , 32 )	( 4710 , 32 )	( 7572 , 32 )	( 9530 , 32 )	( 11582 , 32 )
	AL FIN COILS	801	734	1152	1194	1192	642	479
	CU FIN COILS	811	788	1281	1369	1367	771	533
	RS&LS1 / AL FIN COILS	881	814	1152	1194	1192	722	559
RS&LS1 / CU FIN COILS	891	868	1281	1369	1367	851	613	
1649P	LEFT - L	( 230 , 2207 )	( 1510 , 2207 )	( 3600 , 2207 )	( 5905 , 2207 )	( 8211 , 2207 )	( 10301 , 2207 )	( 11581 , 2207 )
	AL FIN COILS	813	523	1395	1389	1382	1221	454
	CU FIN COILS	779	629	1618	1618	1610	1411	509
	RS&LS1/AL FIN COILS	828	485	1525	1516	1509	1274	433
	RS&LS1/CU FIN COILS	794	590	1748	1745	1737	1463	489
	RIGHT - R	( 230 , 35 )	( 1510 , 35 )	( 3600 , 35 )	( 5905 , 35 )	( 8211 , 35 )	( 10301 , 35 )	( 11581 , 35 )
	AL FIN COILS	813	523	1395	1389	1382	1221	454
	CU FIN COILS	779	629	1618	1618	1610	1411	509
	RS&LS1/AL FIN COILS	828	485	1525	1516	1509	1274	433
RS&LS1/CU FIN COILS	794	590	1748	1745	1737	1463	489	

# Isolator Locations - SI

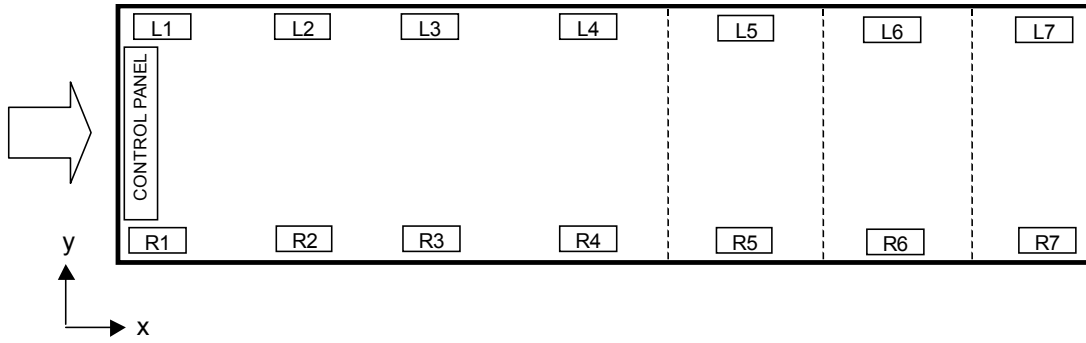

HIGH EFFICIENCY - SI								
MODEL YCIV	ISOLATOR LOCATIONS ( X , Y ) - MM AND POINT LOADS - KG							
50 HZ		1	2	3	4	5	6	7
0590E/V	LEFT - L	( 230 , 2204 )	( 1510 , 2204 )	( 2780 , 2204 )	( 5360 , 2204 )			
	AL FIN COILS	772	723	756	730			
	CU FIN COILS	772	774	912	885			
	RS&LS1 / AL FIN COILS	853	804	756	730			
	RS&LS1 / CU FIN COILS	853	855	912	885			
	RIGHT - R	( 230 , 32 )	( 1510 , 32 )	( 2780 , 32 )	( 5360 , 32 )			
	AL FIN COILS	772	723	756	730			
	CU FIN COILS	772	774	912	885			
	RS&LS1 / AL FIN COILS	853	804	756	730			
	RS&LS1 / CU FIN COILS	853	855	912	885			
0630E/V	LEFT - L	( 230 , 2204 )	( 1510 , 2204 )	( 2780 , 2204 )	( 4970 , 2204 )	( 6740 , 2204 )		
	AL FIN COILS	770	707	707	578	351		
	CU FIN COILS	770	762	861	750	424		
	RS&LS1 / AL FIN COILS	851	788	707	578	351		
	RS&LS1 / CU FIN COILS	851	843	861	750	424		
	RIGHT - R	( 230 , 32 )	( 1510 , 32 )	( 2780 , 32 )	( 4970 , 32 )	( 6740 , 32 )		
	AL FIN COILS	770	707	707	563	301		
	CU FIN COILS	770	762	861	735	374		
	RS&LS1 / AL FIN COILS	851	788	707	563	301		
	RS&LS1 / CU FIN COILS	851	843	861	735	374		
0700E/V	LEFT - L	( 230 , 2204 )	( 1510 , 2204 )	( 2780 , 2204 )	( 4970 , 2204 )	( 6740 , 2204 )		
	AL FIN COILS	778	717	760	584	372		
	CU FIN COILS	778	772	914	756	445		
	RS&LS1 / AL FIN COILS	859	798	760	584	372		
	RS&LS1 / CU FIN COILS	859	853	914	756	445		
	RIGHT - R	( 230 , 32 )	( 1510 , 32 )	( 2780 , 32 )	( 4970 , 32 )	( 6740 , 32 )		
	AL FIN COILS	770	708	708	584	372		
	CU FIN COILS	770	763	862	756	445		
	RS&LS1 / AL FIN COILS	851	789	708	584	372		
	RS&LS1 / CU FIN COILS	851	844	862	756	445		
0760E/V	LEFT - L	( 230 , 2204 )	( 1510 , 2204 )	( 2780 , 2204 )	( 4970 , 2204 )	( 6740 , 2204 )		
	AL FIN COILS	780	730	734	614	390		
	CU FIN COILS	780	785	888	786	463		
	RS&LS1 / AL FIN COILS	861	811	734	614	390		
	RS&LS1 / CU FIN COILS	861	866	888	786	463		
	RIGHT - R	( 230 , 32 )	( 1510 , 32 )	( 2780 , 32 )	( 4970 , 32 )	( 6740 , 32 )		
	AL FIN COILS	780	730	734	614	390		
	CU FIN COILS	780	785	888	786	463		
	RS&LS1 / AL FIN COILS	861	811	734	614	390		
	RS&LS1 / CU FIN COILS	861	866	888	786	463		
0800E/V	LEFT - L	( 230 , 2204 )	( 1510 , 2204 )	( 2470 , 2204 )	( 4100 , 2204 )	( 5350 , 2204 )	( 7820 , 2204 )	
	AL FIN COILS	780	732	491	451	496	432	
	CU FIN COILS	780	773	600	576	654	541	
	RS&LS1 / AL FIN COILS	861	813	491	451	496	432	
	RS&LS1 / CU FIN COILS	861	854	600	576	654	541	
	RIGHT - R	( 230 , 32 )	( 1510 , 32 )	( 2470 , 32 )	( 4100 , 32 )	( 5350 , 32 )	( 7820 , 32 )	
	AL FIN COILS	780	732	491	451	489	433	
	CU FIN COILS	780	773	600	576	647	542	
	RS&LS1 / AL FIN COILS	861	813	491	451	489	433	
	RS&LS1 / CU FIN COILS	861	854	600	576	649	542	

HIGH EFFICIENCY - SI								
MODEL YCIV	ISOLATOR LOCATIONS ( X , Y ) - MM AND POINT LOADS - KG							
50 HZ		1	2	3	4	5	6	7
0830E/V	LEFT - L	( 230 , 2204 )	( 1510 , 2204 )	( 2470 , 2204 )	( 4100 , 2204 )	( 5350 , 2204 )	( 7820 , 2204 )	
	AL FIN COILS	780	733	492	453	500	455	
	CU FIN COILS	780	774	601	578	658	564	
	RS&LS1 / AL FIN COILS	861	814	492	453	500	455	
	RS&LS1 / CU FIN COILS	861	855	601	578	658	564	
	RIGHT - R	( 230 , 32 )	( 1510 , 32 )	( 2470 , 32 )	( 4100 , 32 )	( 5350 , 32 )	( 7820 , 32 )	
	AL FIN COILS	780	733	492	453	500	455	
	CU FIN COILS	780	774	601	578	658	564	
	RS&LS1 / AL FIN COILS	861	814	492	453	500	455	
	RS&LS1 / CU FIN COILS	861	855	601	578	660	564	
0930E/V	LEFT - L	( 230 , 2204 )	( 1510 , 2204 )	( 2470 , 2204 )	( 4100 , 2204 )	( 5350 , 2204 )	( 7820 , 2204 )	
	AL FIN COILS	784	743	566	526	574	456	
	CU FIN COILS	784	784	675	651	732	565	
	RS&LS1 / AL FIN COILS	865	824	566	526	574	456	
	RS&LS1 / CU FIN COILS	865	865	675	651	732	565	
	RIGHT - R	( 230 , 32 )	( 1510 , 32 )	( 2470 , 32 )	( 4100 , 32 )	( 5350 , 32 )	( 7820 , 32 )	
	AL FIN COILS	780	739	566	526	574	456	
	CU FIN COILS	780	780	675	651	732	565	
	RS&LS1 / AL FIN COILS	861	820	566	526	574	456	
	RS&LS1 / CU FIN COILS	861	861	675	651	734	565	
1050E/V	LEFT - L	( 230 , 2204 )	( 1475 , 2204 )	( 2823 , 2204 )	( 5199 , 2204 )	( 7236 , 2204 )	( 9346 , 2204 )	
	AL FIN COILS	795	719	826	834	981	533	
	CU FIN COILS	805	797	982	991	1137	611	
	RS&LS1 / AL FIN COILS	875	799	826	834	1011	633	
	RS&LS1 / CU FIN COILS	885	877	982	991	1167	741	
	RIGHT - R	( 230 , 32 )	( 1475 , 32 )	( 2823 , 32 )	( 5199 , 32 )	( 7236 , 32 )	( 9346 , 32 )	
	AL FIN COILS	795	724	1092	1131	1250	535	
	CU FIN COILS	805	802	1248	1288	1406	613	
	RS&LS1 / AL FIN COILS	875	804	1092	1131	1280	665	
	RS&LS1 / CU FIN COILS	885	882	1248	1288	1436	743	
1120E/V	LEFT - L	( 230 , 2204 )	( 1510 , 2204 )	( 2780 , 2204 )	( 4710 , 2204 )	( 7225 , 2204 )	( 9105 , 2204 )	( 10463 , 2204 )
	AL FIN COILS	795	719	838	848	714	476	421
	CU FIN COILS	805	786	967	1023	889	605	475
	RS&LS1 / AL FIN COILS	875	799	838	848	714	556	501
	RS&LS1 / CU FIN COILS	855	866	967	1023	889	685	555
	RIGHT - R	( 230 , 32 )	( 1510 , 32 )	( 2780 , 32 )	( 4710 , 32 )	( 7225 , 32 )	( 9105 , 32 )	( 10463 , 32 )
	AL FIN COILS	795	724	1104	1145	1063	508	421
	CU FIN COILS	805	778	1233	1320	1238	637	475
	RS&LS1 / AL FIN COILS	875	804	1104	1145	1063	588	501
	RS&LS1 / CU FIN COILS	885	858	1233	1320	1238	717	555
1220E/V	LEFT - L	( 230 , 2204 )	( 1510 , 2204 )	( 2780 , 2204 )	( 4710 , 2204 )	( 7225 , 2204 )	( 9105 , 2204 )	( 10463 , 2204 )
	AL FIN COILS	795	719	886	897	886	517	421
	CU FIN COILS	805	786	1015	1072	1061	646	475
	RS&LS1 / AL FIN COILS	875	799	886	897	886	597	501
	RS&LS1 / CU FIN COILS	885	876	1015	1072	1061	726	555
	RIGHT - R	( 230 , 32 )	( 1510 , 32 )	( 2780 , 32 )	( 4710 , 32 )	( 7225 , 32 )	( 9105 , 32 )	( 10463 , 32 )
	AL FIN COILS	795	724	1152	1194	1152	522	421
	CU FIN COILS	805	778	1281	1369	1327	651	475
	RS&LS1 / AL FIN COILS	875	804	1152	1194	1152	602	501
	RS&LS1 / CU FIN COILS	885	858	1281	1369	1327	731	555
1380E/V	LEFT - L	( 230 , 2204 )	( 1510 , 2204 )	( 2780 , 2204 )	( 4710 , 2204 )	( 7572 , 2204 )	( 9530 , 2204 )	( 11582 , 2204 )
	AL FIN COILS	801	729	886	897	926	637	471
	CU FIN COILS	811	796	1015	1072	1101	766	525
	RS&LS1 / AL FIN COILS	881	809	886	897	926	717	551
	RS&LS1 / CU FIN COILS	891	876	1015	1072	1101	846	605
	RIGHT - R	( 230 , 32 )	( 1510 , 32 )	( 2780 , 32 )	( 4710 , 32 )	( 7572 , 32 )	( 9530 , 32 )	( 11582 , 32 )
	AL FIN COILS	801	734	1152	1194	1192	642	471
	CU FIN COILS	811	788	1281	1369	1367	771	525
	RS&LS1 / AL FIN COILS	881	814	1152	1194	1192	722	551
	RS&LS1 / CU FIN COILS	891	868	1281	1369	1367	851	605

## ONE INCH DEFLECTION SPRING ISOLATOR CROSS-REFERENCE

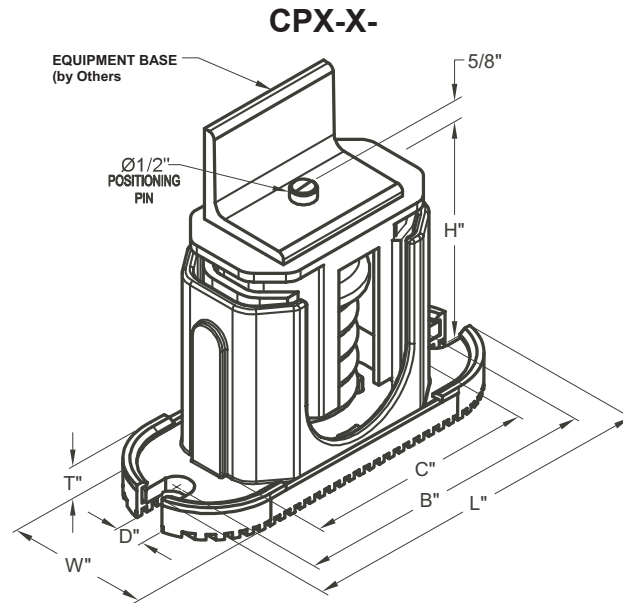

MOUNT TYPE	DIMENSION DATA (INCHES)						
	W	D	L	B	C	T	H
CP	3	5/8	7-3/4	6-1/2	4-3/4	1/2	5-5/8
C2P	3	5/8	10-1/2	9-1/4	7-3/4	9/16	6

MODEL NUMBER	COLOR CODE	RATED CAPACITY (FOR UNITS WITH ALL LOAD POINTS LESS THAN 1785 LBS (810 KG))	
		(LBS.)	(KG)
CP-1D-510	BLACK	UP THRU 434	UP THRU 197
CP-1D-900	DARK GREEN	435 THRU 765	198 THRU 347
CP-1D-1200	GRAY	766 THRU 1020	348 THRU 463
CP-1D-1360	WHITE	1021 THRU 1156	464 THRU 524
CP-1D-1785N	GRAY/RED	1157 THRU 1785	525 THRU 810

MODEL NUMBER	COLOR CODE	RATED CAPACITY (FOR UNITS WITH ANY LOAD POINT ABOVE 1518 LBS (689 KG))	
		(LBS.)	(KG)
C2P-1D-1350	DARK PURPLE	UP THRU 1148	UP TO 521
C2P-1D-1800	DARK GREEN	1149 THRU 1530	522 - 694
C2P-1D-2400	GRAY	1531 THRU 2040	695 - 925
C2P-1D-2400	GRAY	1531 THRU 2040	695 - 925
C2P-1D-2720	WHITE	2041 THRU 2312	926 - 1049
C2P-1D-3570N	GRAY/RED	2313 THRU 3570	1050 - 1619

Note: Do not mix isolators types

**ELASTOMERIC ISOLATOR CROSS-REFERENCE**

**RD-Style Isolators**

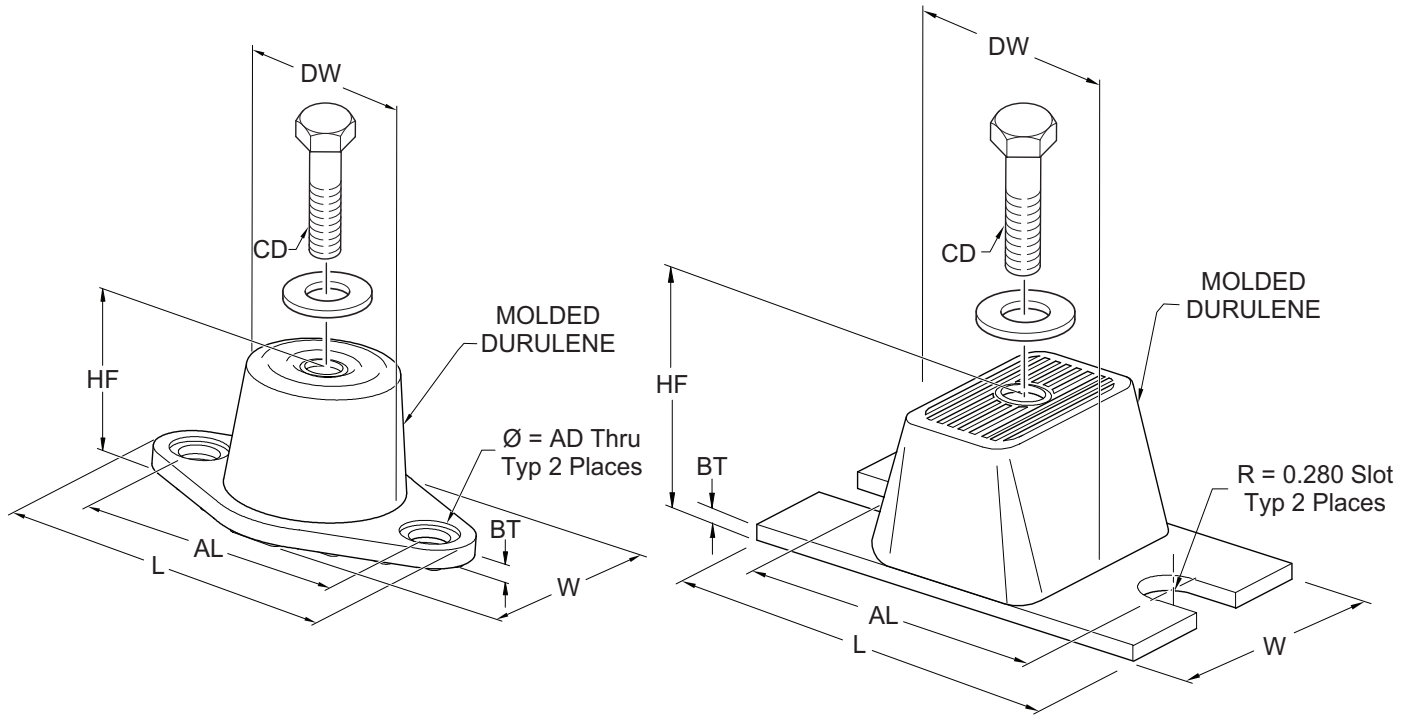

LD17304

MOUNT TYPE	DIMENSION DATA (INCHES)							
	L	W	HF	AL	AD	BT	CD	DW
RD1-WR	3.13	1.75	1.25	2.38	0.34	0.19	5/16-18 UNC X 3/4	1.25
RD2-WR	3.88	2.38	1.75	3.00	0.34	0.22	3/8-16 UNC X 1	1.75
RD3-WR	5.50	3.38	2.88	4.13	0.56	0.25	1/2-13 UNC X 1	2.50
RD4-WR	6.25	4.63	2.75	5.00	0.56	0.38	1/2-13 UNC X 1	3.00

MODEL NUMBER	ISOLATOR COLOR	WEIGHT RANGE (LBS)	WEIGHT RANGE (KGS)
RD-3-CHARCOAL-WR	CHARCOAL	UP THRU 825	UP TO 374
RD-4-BRICK RED-WR	BRICK RED	826 THRU 1688	375 - 766
RD-4-CHARCOAL-WR	CHARCOAL	1689 THRU 4000	767 - 1814

## TWO INCH DEFLECTION, SEISMIC SPRING ISOLATOR CROSS-REFERENCE

### Y2RS

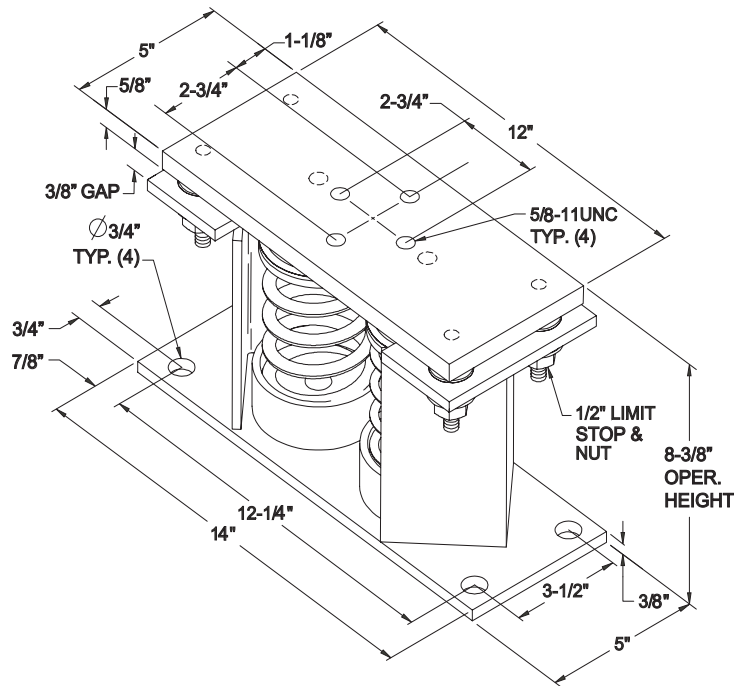

### MODEL Y2RSI-2D SEISMICALLY RESTRAINED VIBRATION ISOLATOR FOR 2" DEFLECTION

MODEL NUMBER	ISOL. COLOR	WEIGHT RANGE (LBS)	WEIGHT RANGE (KGS)
Y2RSI-2D-460	GREEN	UP THRU 391	UP TO 177
Y2RSI-2D-710	DARK BROWN	392 THRU 604	178 - 274
Y2RSI-2D-870	RED	605 THRU 740	275 - 336
Y2RSI-2D-1200N	RED/BLACK	741 THRU 1020	337 - 463
Y2RSI-2D-1690	PINK	1021 THRU 1437	464 - 652
Y2RSI-2D-2640N	PINK/GRAY	1438 THRU 2244	653 - 1018
Y2RSI-2D-2870N	PINK/GRAY/ORANGE	2245 THRU 2618	1019 - 1188
Y2RSI-2D-3280N	PINK/GRAY/DK.BROWN	2619 THRU 3740	1189 - 1696

INTENTIONALLY LEFT BLANK

# Electrical Data - 2 Comp Standard Efficiency

FORM 201.23-EG2 (713)

STANDARD EFFICIENCY YCIV____ S/P											
MODEL NO./NAMEPLATE			SYSTEM 1								
			STD. & ULTRA QUIET COND. FANS			HIGH HEAD/STATIC COND. FANS			TWO-SPEED COND. FANS		
YCIV S/P	INPUT VOLTS (9)	INPUT FREQ	COMPRES-SOR RLA (5)	CONDENSER FANS		COMPRES-SOR RLA (5)	CONDENSER FANS		COMPRES-SOR RLA (5)	CONDENSER FANS	
				QTY.	FLA (EA)		QTY.	FLA (EA)		QTY.	FLA (EA)
0600	400	50	144	4	3.1	144	4	9.3	152	4	3.8
0650	400	50	191	4	3.1	191	4	9.3	198	4	3.8
0720	400	50	195	5	3.1	195	5	9.3	207	5	3.8
0770	400	50	174	5	3.1	174	5	9.3	185	5	3.8
0840	400	50	194	5	3.1	194	5	9.3	206	5	3.8
0920	400	50	232	6	3.1	232	6	9.3	246	6	3.8
1000	400	50	230	6	3.1	230	6	9.3	243	6	3.8

YCIV S/P	CONTROL KVA (7)	UNIT SHORT CIRCUIT WITH-STAND (KA)		FIELD WIRING & PROTECTION			
		TERMINAL BLOCK (STD)	CIRCUIT BREAKER (OPT)	STD. & ULTRA QUIET COND. FANS			
				MINIMUM CKT. AMPACITY (MCA) (3)	RECOMMENDED FUSE/CKT. BREAKER RATING (4)	MAX. INVERSE TIME CKT. BRKR. RATING (2)	MAX DUAL ELEMENT FUSE SIZE (2)
0600	1.8	30KA	65KA	350	400	450	450
0650	1.8	30KA	65KA	390	450	500	500
0720	1.8	30KA	65KA	416	500	600	600
0770	1.8	30KA	65KA	446	500	600	600
0840	1.8	30KA	65KA	468	600	600	600
0920	1.8	30KA	65KA	517	600	700	700
1000	1.8	30KA	65KA	555	700	700	700

See page 64 for Electrical Data footnotes.



STANDARD EFFICIENCY YCIV\_\_\_\_S/P

SYSTEM 2								
STD. & ULTRA QUIET COND. FANS			HIGH HEAD/STATIC COND. FANS			TWO-SPEED COND. FANS		
COMPRES-SOR RLA (5)	CONDENSER FANS		COMPRES-SOR RLA (5)	CONDENSER FANS		COMPRES-SOR RLA (5)	CONDENSER FANS	
	QTY.	FLA (EA)		QTY.	FLA (EA)		QTY.	FLA (EA)
144	4	3.1	144	4	9.3	152	4	3.8
127	4	3.1	127	4	9.3	132	4	3.8
144	4	3.1	144	4	9.3	152	4	3.8
195	4	3.1	195	4	9.3	201	4	3.8
194	5	3.1	194	5	9.3	206	5	3.8
192	5	3.1	192	5	9.3	204	5	3.8
230	6	3.1	230	6	9.3	243	6	3.8

HIGH HEAD/HIGH STATIC FANS				TWO-SPEED COND. FANS			
MINIMUM CKT. AMPACITY (MCA) (3)	RECOMMENDED FUSE/CKT. BREAKER RATING (4)	MAX. INVERSE TIME CKT. BRKR. RATING (2)	MAX DUAL ELEMENT FUSE SIZE (2)	MINIMUM CKT. AMPACITY (MCA) (3)	RECOMMENDED FUSE/CKT. BREAKER RATING (4)	MAX. INVERSE TIME CKT. BRKR. RATING (2)	MAX DUAL ELEMENT FUSE SIZE (2)
373	450	500	500	399	450	500	500
410	500	600	600	440	500	600	600
445	500	600	600	472	600	600	600
471	600	600	600	502	600	700	700
502	600	700	700	530	600	700	700
553	700	800	800	585	700	800	800
593	700	800	800	629	700	800	800

# Electrical Data - 2 Comp High Efficiency

HIGH EFFICIENCY YCIV____E/V											
MODEL NO./NAMEPLATE			SYSTEM 1								
			STD. & ULTRA QUIET COND. FANS			HIGH HEAD/STATIC COND. FANS			TWO-SPEED COND. FANS		
YCIV E/V	INPUT VOLTS (9)	INPUT FREQ	COMPRES-SOR	CONDENSER FANS		COMPRES-SOR	CONDENSER FANS		COMPRES-SOR	CONDENSER FANS	
			RLA (5)	QTY.	FLA (EA)	RLA (5)	QTY.	FLA (EA)	RLA (5)	QTY.	FLA (EA)
0590	400	50	132	4	3.1	132	4	9.3	138	4	3.8
0630	400	50	134	5	3.1	134	5	9.3	139	5	3.8
0700	400	50	185	5	3.1	185	5	9.3	196	5	3.8
0760	400	50	170	5	3.1	170	5	9.3	180	5	3.8
0800	400	50	170	6	3.1	170	6	9.3	178	6	3.8
0830	400	50	180	6	3.1	180	6	9.3	189	6	3.8
0930	400	50	233	6	3.1	233	6	9.3	246	6	3.8

YCIV E/V	CONTROL KVA (7)	UNIT SHORT CIRCUIT WITH-STAND (KA)		FIELD WIRING & PROTECTION			
				STD. & ULTRA QUIET COND. FANS			
		TERMINAL BLOCK (STD)	CIRCUIT BREAKER (OPT)	MINIMUM CKT. AMPACITY (MCA) (3)	RECOMMENDED FUSE/CKT. BREAKER RATING (4)	MAX. INVERSE TIME CKT. BRKR. RATING (2)	MAX DUAL ELEMENT FUSE SIZE (2)
0590	1.8	30KA	65KA	322	400	450	450
0630	1.8	30KA	65KA	344	400	450	450
0700	1.8	30KA	65KA	388	450	500	500
0760	1.8	30KA	65KA	412	500	500	500
0800	1.8	30KA	65KA	433	500	600	600
0830	1.8	30KA	65KA	443	500	600	600
0930	1.8	30KA	65KA	506	600	700	700

HIGH EFFICIENCY YCIV____E/V								
SYSTEM 2								
STD. & ULTRA QUIET COND. FANS			HIGH HEAD/STATIC COND. FANS			TWO-SPEED COND. FANS		
COMPRES-SOR	CONDENSER FANS		COMPRES-SOR	CONDENSER FANS		COMPRES-SOR	CONDENSER FANS	
RLA (5)	QTY.	FLA (EA)	RLA (5)	QTY.	FLA (EA)	RLA (5)	QTY.	FLA (EA)
132	4	3.1	132	4	9.3	138	4	3.8
146	4	3.1	146	4	9.3	154	4	3.8
126	5	3.1	126	5	9.3	131	5	3.8
170	5	3.1	170	5	9.3	180	5	3.8
183	5	3.1	183	5	9.3	195	5	3.8
180	6	3.1	180	6	9.3	189	6	3.8
178	6	3.1	178	6	9.3	187	6	3.8

HIGH HEAD/HIGH STATIC FANS				TWO-SPEED COND. FANS			
MINIMUM CKT. AMPACITY (MCA) (3)	RECOMMENDED FUSE/CKT. BREAKER RATING (4)	MAX. INVERSE TIME CKT. BRKR. RATING (2)	MAX DUAL ELEMENT FUSE SIZE (2)	MINIMUM CKT. AMPACITY (MCA) (3)	RECOMMENDED FUSE/CKT. BREAKER RATING (4)	MAX. INVERSE TIME CKT. BRKR. RATING (2)	MAX DUAL ELEMENT FUSE SIZE (2)
372	450	500	500	342	400	450	450
400	450	500	500	366	450	500	500
450	500	600	600	414	500	600	600
474	600	600	600	442	500	600	600
501	600	600	600	463	600	600	600
517	600	700	700	472	600	600	600
581	700	800	800	541	700	700	700

# Electrical Data - 3 & 4 Comp Standard Efficiency

MODEL			SYSTEM 1									SYSTEM 2								
			STD. & ULTRA QUIET COND. FANS			HIGH HEAD/STATIC COND. FANS			TWO-SPEED COND. FANS			STD. & ULTRA QUIET COND. FANS			HIGH HEAD/STATIC COND. FANS			TWO-SPEED COND. FANS		
YCV S/P	INPUT VOLTS (9)	INPUT FREQ	COMP.	COND. FANS		COMP.	COND. FANS		COMP.	COND. FANS		COMP.	COND. FANS		COMP.	COND. FANS		COMP.	COND. FANS	
			RLA (5)	QTY.	FLA (EA)	RLA (5)	QTY.	FLA (EA)	RLA (5)	QTY.	FLA (EA)	RLA (5)	QTY.	FLA (EA)	RLA (5)	QTY.	FLA (EA)	RLA (5)	QTY.	FLA (EA)
1070	400	50	175	5	3.1	175	5	9.3	186	5	3.8	196	4	3.1	196	4	9.3	202	4	3.8
1180	400	50	177	5	3.1	177	5	9.3	188	5	3.8	177	5	3.1	177	5	9.3	188	5	3.8
1340	400	50	192	5	3.1	192	5	9.3	204	5	3.8	192	5	3.1	192	5	9.3	204	5	3.8
1500	400	50	229	6	3.1	229	6	9.3	243	6	3.8	229	6	3.1	229	6	9.3	243	6	3.8
1649	400	50	N/A	N/A	N/A	219	6	6	N/A	N/A	N/A	N/A	N/A	N/A	219	6	6	N/A	N/A	N/A

YCV S/P	CONTROL KVA (7)	UNIT SHORT CIRCUIT WITHSTAND (KA)		FIELD WIRING & PROTECTION					
				STD. & ULTRA QUIET COND. FANS			HIGH HEAD/HIGH STATIC FANS		
		TERMINAL BLOCK (STD)	CIRCUIT BREAKER (OPT)	MINIMUM CKT. AMPACITY (MCA) (3)	RECOM. FUSE/CKT. BREAKER RATING (4)	MAX. INVERSE TIME CKT. BRKR. RATING (2)	MAX DUAL ELEMENT FUSE SIZE (2)	MINIMUM CKT. AMPACITY (MCA) (3)	RECOM-MENDED FUSE/CKT. BREAKER RATING (4)
1070	2.4	30KA	65KA	590	700	700	700	671	800
1180	2.4	30KA	65KA	644	700	800	800	731	800
1340	2.4	30KA	65KA	724	800	800	800	824	1000
1500	2.4	30KA	65KA	801	1000	1000	1000	913	1000
1649	4	30KA	65KA	N/A	N/A	N/A	N/A	537	600

See page 64 for Electrical Data footnotes.

SYSTEM 3									SYSTEM 4								
STD. & ULTRA QUIET COND. FANS			HIGH HEAD/STATIC COND. FANS			TWO-SPEED COND. FANS			STD & ULTRA QUIET COND FANS			HIGH HEAD/STATIC COND. FANS			TWO-SPEED COND FANS		
COMP.	COND. FANS		COMP.	COND. FANS		COMP.	COND. FANS		COMP.	COND. FANS		COMP.	COND. FANS		COMP.	COND. FANS	
RLA (5)	QTY.	FLA (EA)	RLA (5)	QTY.	FLA (EA)	RLA (5)	QTY.	FLA (EA)	RLA (5)	QTY.	FLA (EA)	RLA (5)	QTY.	FLA (EA)	RLA (5)	QTY.	FLA (EA)
129	4	3.1	129	4	9.3	135	4	3.8									
198	4	3.1	198	4	9.3	203	4	3.8									
232	6	3.1	232	6	9.3	245	6	3.8									
229	6	3.1	229	6	9.3	243	6	3.8									
N/A	N/A	N/A	209	3	6	N/A	N/A	N/A	N/A	N/A	N/A	209	3	6	N/A	N/A	N/A

FIELD WIRING & PROTECTION						FIELD WIRING LUGS							
HIGH HEAD/HIGH STATIC FANS		TWO-SPEED COND. FANS				STD TERMINAL BLOCK				OPT CIRCUIT BREAKER			
MAX. INVERSE TIME CKT. BRKR. RATING (2)	MAX DUAL ELEMENT FUSE SIZE (2)	MINIMUM CKT. AMPACITY (MCA) (3)	RECOM-MENDED FUSE/ CKT. BREAKER RATING (4)	MAX. INVERSE TIME CKT. BRKR. RATING (2)	MAX DUAL ELEMENT FUSE SIZE (2)	SYSTEMS 1 & 3		SYSTEMS 2 & 4		SYSTEMS 1 & 3		SYSTEMS 2 & 4	
						LUGS/ PHASE (1)	LUG WIRE RANGE	LUGS/ PHASE (1)	LUG WIRE RANGE	LUGS/ PHASE (1)	LUG WIRE RANGE	LUGS/ PHASE (1)	LUG WIRE RANGE
800	800	623	700	800	800	4	#2 - 600 KCM			4	#4/0 - 500 KCM		
800	800	683	800	800	800	4	#2 - 600 KCM			4	#4/0 - 500 KCM		
1000	1000	776	1000	1000	1000	4	#2 - 600 KCM			4	#4/0 - 500 KCM		
1000	1000	857	1000	1000	1000	4	#2 - 600 KCM			4	#4/0 - 500 KCM		
700	700	N/A	N/A	N/A	N/A	3	#2 - 600KCM	3	#2 - 600KCM	4	#2 -400KCM	4	#2 -400KCM

# Electrical Data - 3 Comp High Efficiency

FORM 201.23-EG2 (713)

MODEL NO./NAMEPLATE			SYSTEM 1									SYSTEM 2		
			STD. & ULTRA QUIET COND. FANS			HIGH HEAD/STATIC COND. FANS			TWO-SPEED COND. FANS			STD. & ULTRA QUIET COND. FANS		
YCIV E/V	INPUT VOLTS (9)	INPUT FREQ	COMP.			CONDENSER FANS			COMP.			CONDENSER FANS		
			RLA (5)	QTY.	FLA (EA)	RLA (5)	QTY.	FLA (EA)	RLA (5)	QTY.	FLA (EA)	RLA (5)	QTY.	FLA (EA)
1050	400	50	170	5	3.1	170	5	9.3	180	5	3.8	170	5	3.1
1120	400	50	164	5	3.1	164	5	9.3	173	5	3.8	164	5	3.1
1220	400	50	183	5	3.1	183	5	9.3	194	5	3.8	183	5	3.1
1380	400	50	218	6	3.1	218	6	9.3	229	6	3.8	218	6	3.1

YCIV S/P	CONTROL KVA (7)	UNIT SHORT CIRCUIT WITHSTAND (KA)		FIELD WIRING & PROTECTION					
				STD. & ULTRA QUIET COND. FANS				HIGH HEAD/HIGH STATIC FANS	
		TERMINAL BLOCK (STD)	CIRCUIT BREAKER (OPT)	MINIMUM CKT. AMPACITY (MCA) (3)	RECOMMENDED FUSE/CKT. BREAKER RATING (4)	MAX. INVERSE TIME CKT. BRKR. RATING (2)	MAX DUAL ELEMENT FUSE SIZE (2)	MINIMUM CKT. AMPACITY (MCA) (3)	RECOMMENDED FUSE/CKT. BREAKER RATING (4)
1070	2.4	30KA	65KA	552	600	700	700	639	700
1180	2.4	30KA	65KA	580	700	700	700	673	800
1340	2.4	30KA	65KA	631	700	800	800	730	800
1500	2.4	30KA	65KA	713	800	800	800	824	1000

See page 64 for Electrical Data footnotes.

SYSTEM 2						SYSTEM 3								
HIGH HEAD/STATIC COND. FANS			TWO-SPEED COND. FANS			STD. & ULTRA QUIET COND. FANS			HIGH HEAD/STATIC COND. FANS			TWO-SPEED COND. FANS		
COMP.		CONDENSER FANS	COMP.	CONDENSER FANS		COMP.	CON-DENSER FANS		COMP.	CON-DENSER FANS		COMP.	CONDENSER FANS	
RLA (5)	QTY.	FLA (EA)	RLA (5)	QTY.	FLA (EA)	RLA (5)	QTY.	FLA (EA)	RLA (5)	QTY.	FLA (EA)	RLA (5)	QTY.	FLA (EA)
170	5	9.3	180	5	3.8	126	4	3.1	126	4	9.3	132	4	3.8
164	5	9.3	173	5	3.8	164	5	3.1	164	5	9.3	173	5	3.8
183	5	9.3	194	5	3.8	169	6	3.1	169	6	9.3	178	6	3.8
218	6	9.3	229	6	3.8	167	6	3.1	167	6	9.3	175	6	3.8

FIELD WIRING & PROTECTION						FIELD WIRING LUGS			
HIGH HEAD/HIGH STATIC FANS		TWO-SPEED COND. FANS				STD TERMINAL BLOCK		OPT CIRCUIT BREAKER	
MAX. INVERSE TIME CKT. BRKR. RATING (2)	MAX DUAL ELEMENT FUSE SIZE (2)	MINIMUM CKT. AMPACITY (MCA) (3)	RECOM-MENDED FUSE/CKT. BREAKER RATING (4)	MAX. IN-VERSE TIME CKT. BRKR. RATING (2)	MAX DUAL ELEMENT FUSE SIZE (2)	LUGS/ PHASE (1)	LUG WIRE RANGE	LUGS/ PHASE (1)	LUG WIRE RANGE
800	800	590	700	700	700	4	#2 - 600 KCM	4	#2 - 600 KCM
800	800	621	700	700	700	4	#2 - 600 KCM	4	#2 - 600 KCM
800	800	676	800	800	800	4	#2 - 600 KCM	4	#2 - 600 KCM
1000	1000	760	800	800	800	4	#2 - 600 KCM	4	#2 - 600 KCM

# Electrical Notes

1. As standard, all 2 and 3 compressor units have single point power connections. The YCIV0457PA/ YCIV1649PA has dual point power connection as standard. Contact factory for information regarding dual point power 2 and 3 compressor units.
2. Maximum Inverse Time Circuit Breaker or Dual Element Fuse - 225% of the largest compressor RLA plus the sum of all other loads per NEC 440.22 (A).
3. MCA - Minimum Circuit Ampacity - 125% of the largest compressor RLA plus 100% of the remaining compressor RLA's plus the sum of all condenser fan FLA's per NEC 440.33
4. Recommended time delay or dual element fuse size - 150% of the largest compressor RLA plus 100% of the remaining compressor RLA's plus the sum of all condenser fan FLA's.
5. RLA - Rated Load Amps - rated in accordance with UL standard 1995.
6. Local codes may take precedence.
7. Control KVA includes operational controls and evaporator heaters.
8. System inrush current is less than RLA due to the use of York Variable Speed Drive technology. Typical Compressor Starting Current ( first four seconds of startup):

<u>Rated Voltage</u>	<u>Typical Starting Current per Compressor</u>
380-400/50/3	28A
380/60/3	29A
460/60/3	23A

9. Voltage Utilization Range:

<u>Rated Voltage</u>	<u>Utilization Range</u>
380-415/50/3	360 - 440
380/60/3	342 - 402
460/60/3	414 - 508

## LEGEND

C.B.	CIRCUIT BREAKER
D.E.	DUAL ELEMENT FUSE
DISC SW	DISCONNECT SWITCH
FACT CB	FACTORY-MOUNTED CIRCUIT BREAKER
FLA	FULL LOAD AMPS
HZ	HERTZ
MAX	MAXIMUM
MCA	MINIMUM CIRCUIT AMPACITY
MIN	MINIMUM
MIN NF	MINIMUM NON-FUSED
RLA	RATED LOAD AMPS
S.P. WIRE	SINGLE-POINT WIRING

## NOTES:

1. U.L. Label is provided on 50 and 60 Hz units for these electrical wiring configurations.
2. — — — — — Dashed Line = Field Provided Wiring.
3. The above recommendations are based on the National Electric Code and using copper conductors only. Field wiring must also comply with local codes. Group Rated breaker must be HACR type for cUL machines.



## 2 COMPRESSOR POWER WIRING CONNECTIONS

2 COMPRESSOR POWER WIRING CONNECTIONS

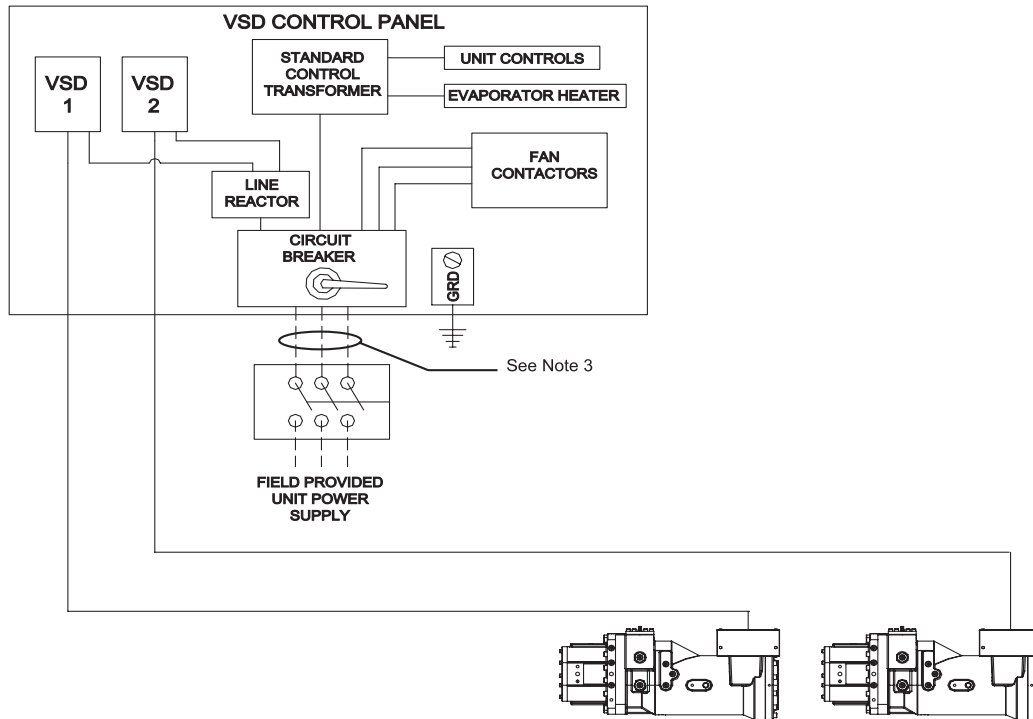

FIG. 1 – TWO COMPRESSOR WIRING DIAGRAM WITH CIRCUIT BREAKER

2 COMPRESSOR POWER WIRING CONNECTIONS

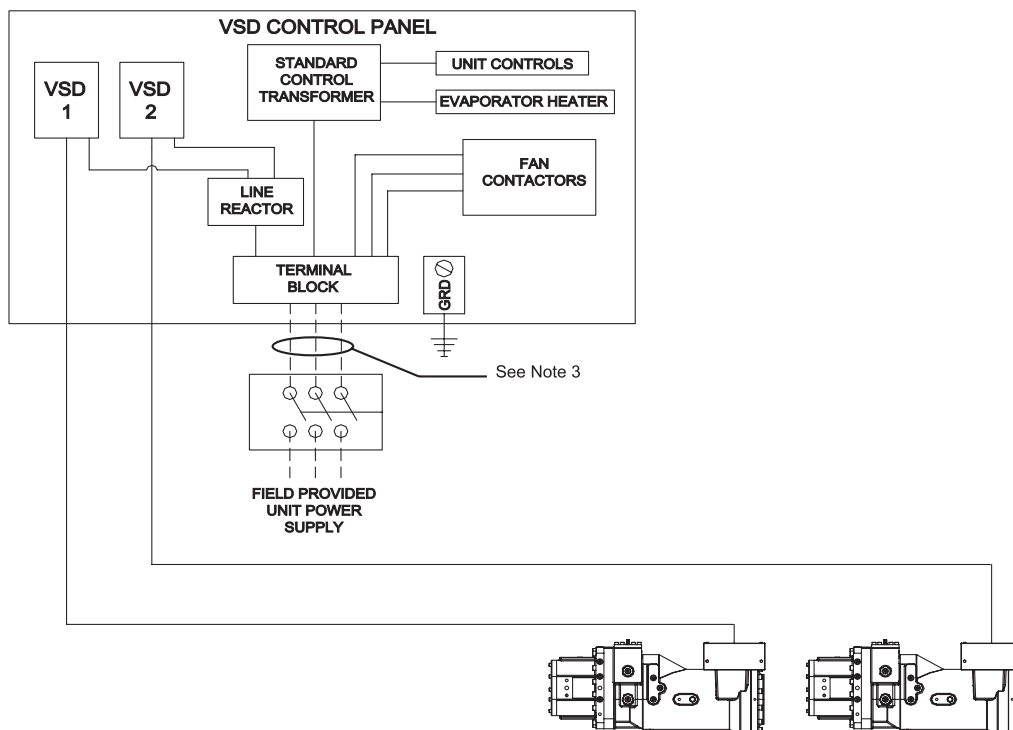

FIG. 2 – TWO COMPRESSOR WIRING DIAGRAM WITH TERMINAL BLOCK

3 COMPRESSOR POWER WIRING CONNECTIONS

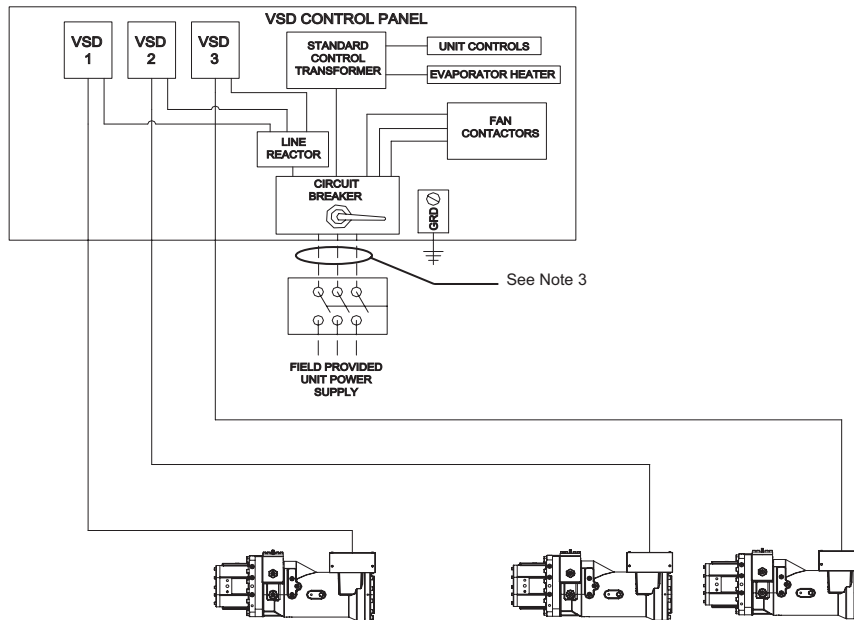

FIG. 3 – THREE COMPRESSOR WIRING DIAGRAM WITH CIRCUIT BREAKER – SINGLE POINT

3 COMPRESSOR POWER WIRING CONNECTIONS

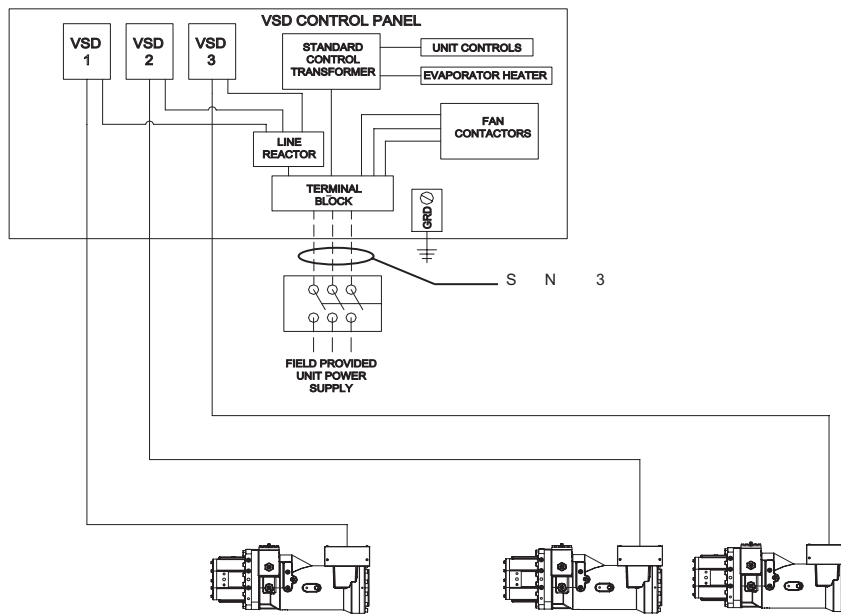

FIG. 4 – THREE COMPRESSOR WIRING DIAGRAM WITH TERMINAL BLOCK – SINGLE POINT

4 COMPRESSOR POWER WIRING CONNECTIONS

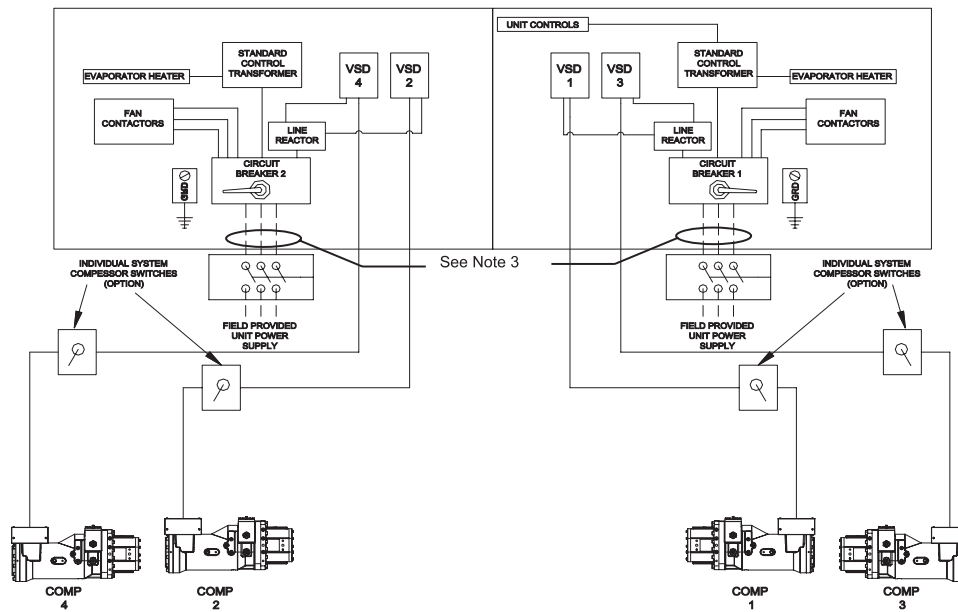

FIG. 7 – FOUR COMPRESSOR WIRING DIAGRAM WITH CIRCUIT BREAKER – MULTI POINT

4 COMPRESSOR POWER WIRING CONNECTIONS

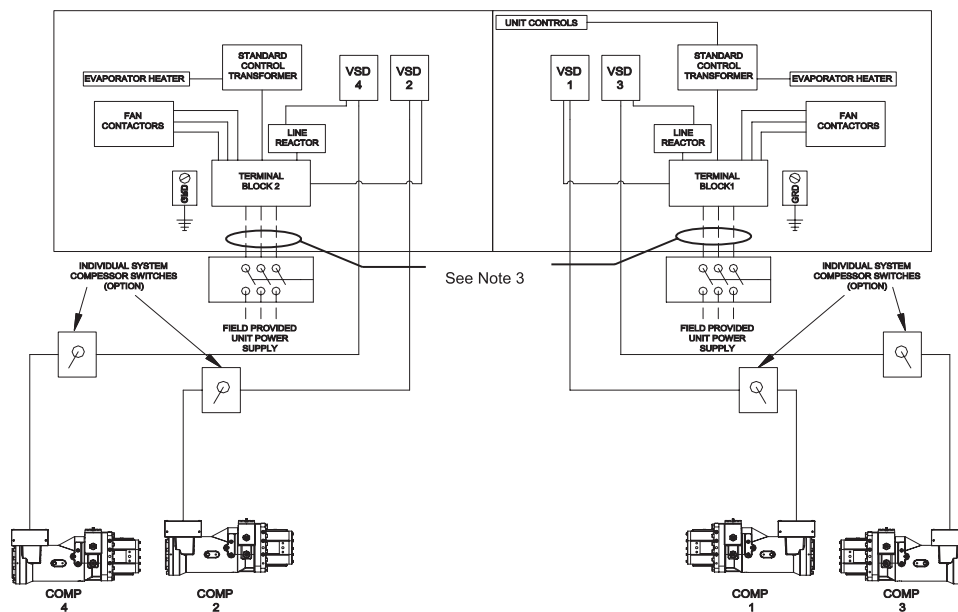
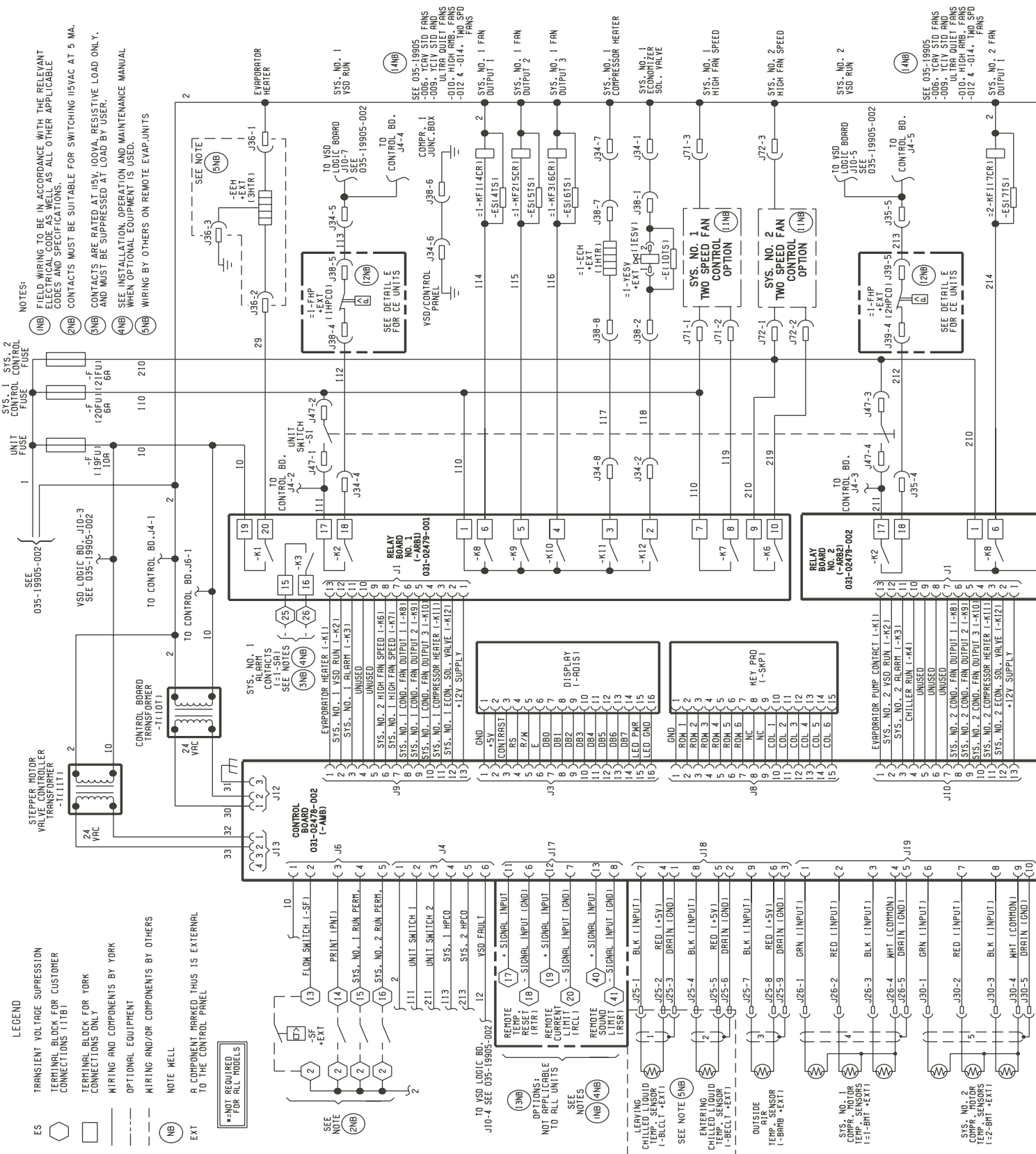
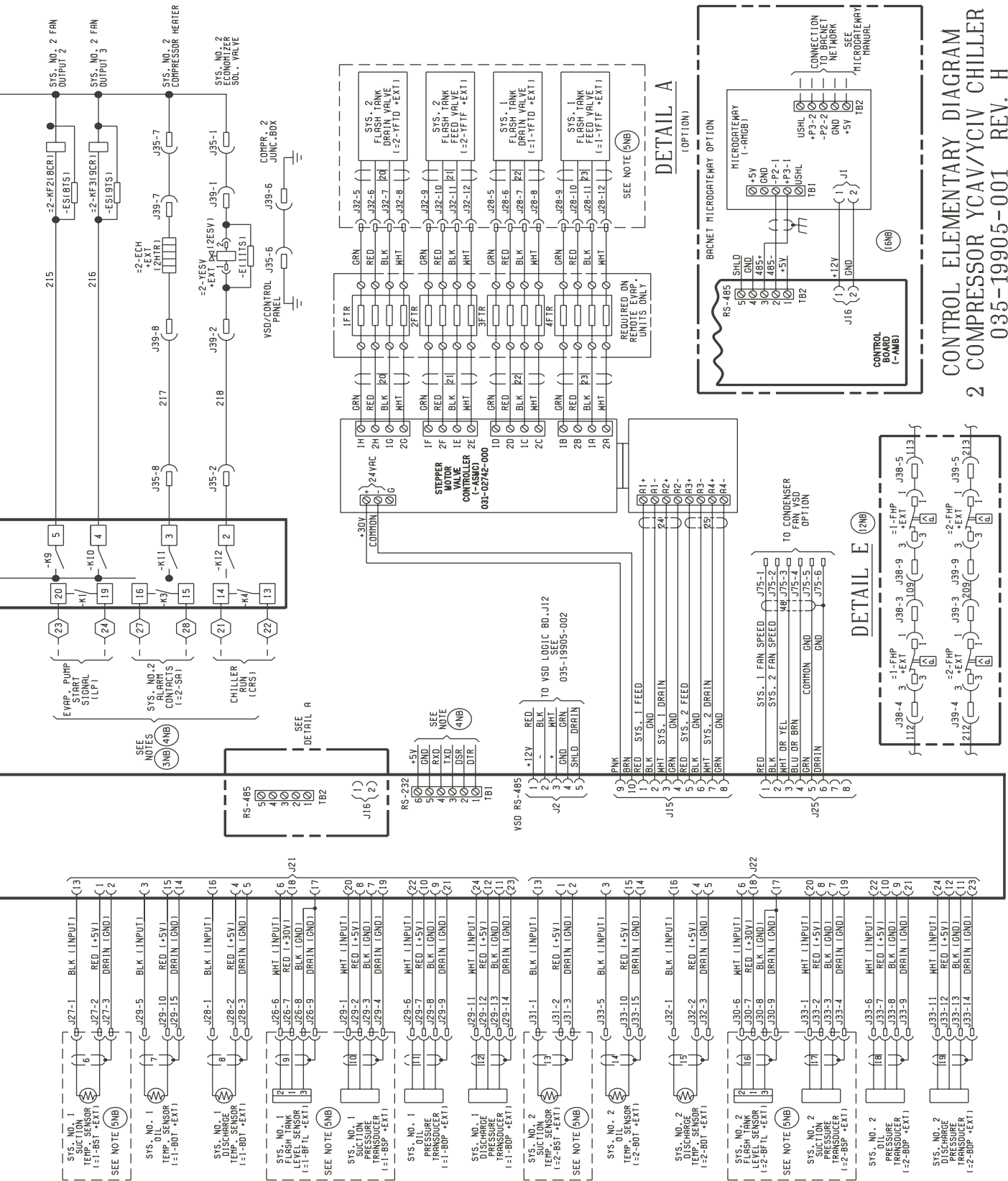

FIG. 8 – FOUR COMPRESSOR WIRING DIAGRAM WITH TERMINAL BLOCK – MULTI POINT

# Typical Control Wiring - Two Compressor





**CONTROL ELEMENTARY DIAGRAM**  
**2 COMPRESSOR YCAV/YCIV CHILLER**  
**035-19905-001 REV. H**

For informational purposes only. Do not attempt to tie into wiring without a proper wiring diagram.  
**JOHNSON CONTROLS**

# Typical Control Wiring - Three Compressor

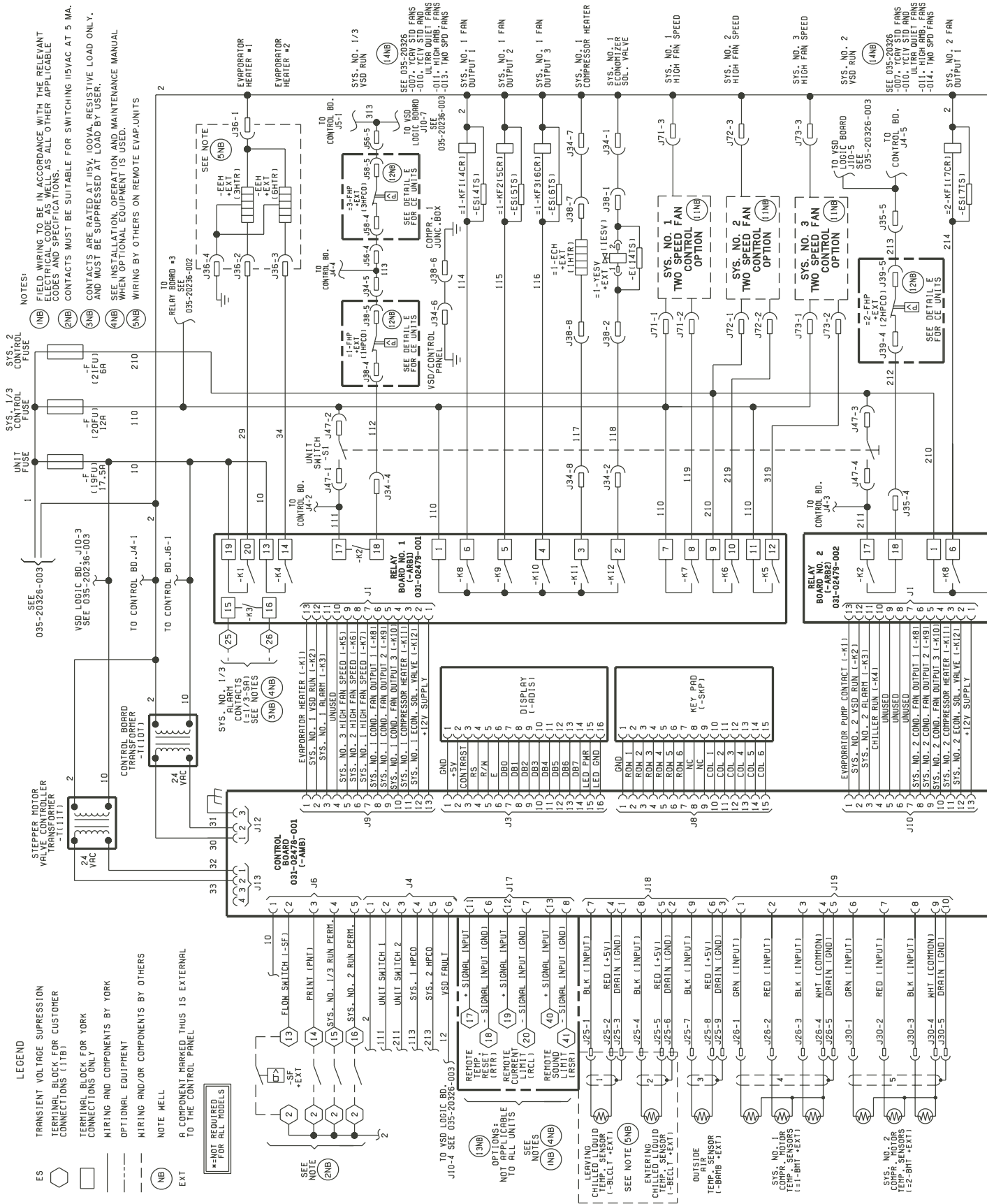

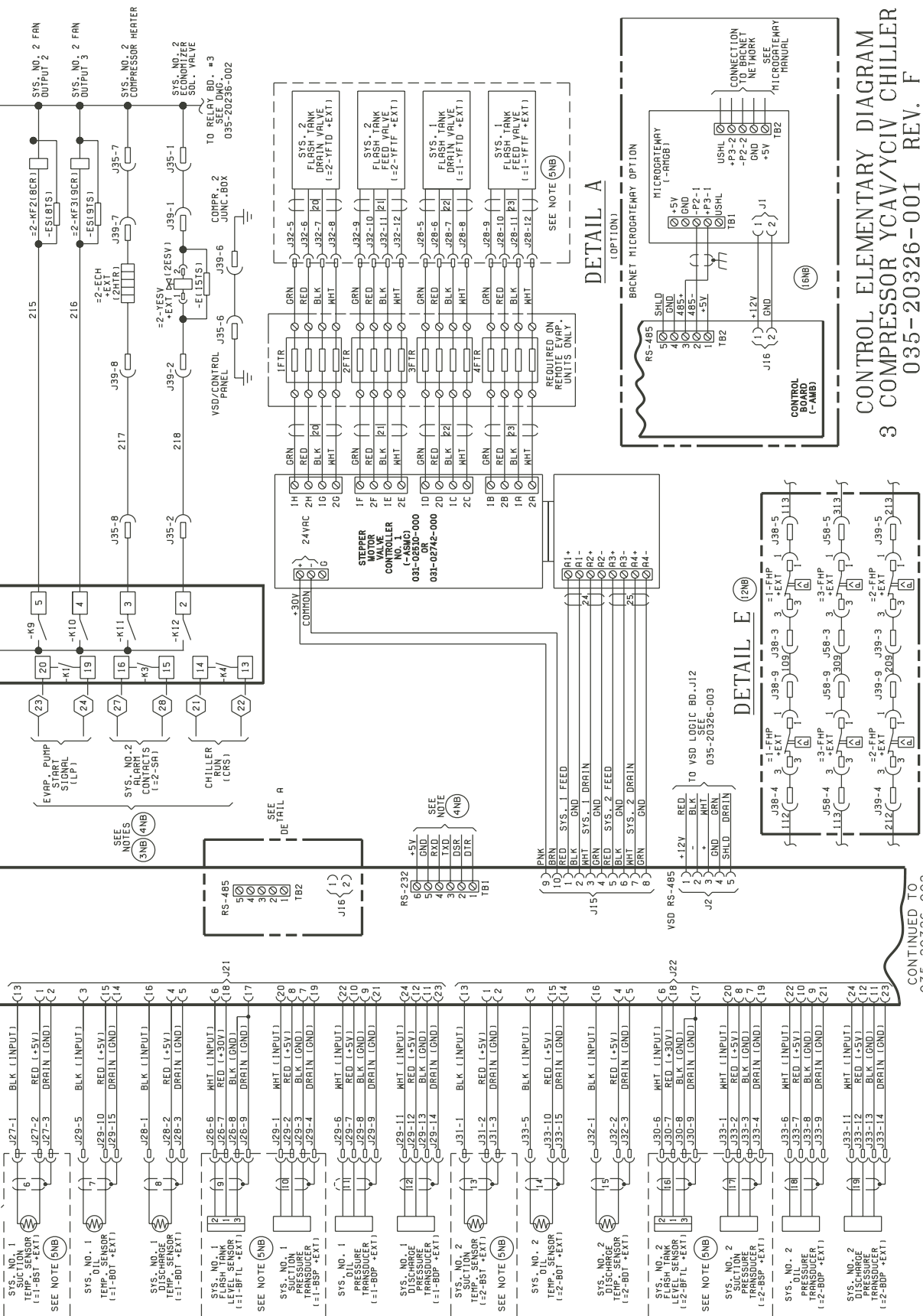

CONTINUED TO  
035-20326-002

# Typical Control Wiring - Four Compressor

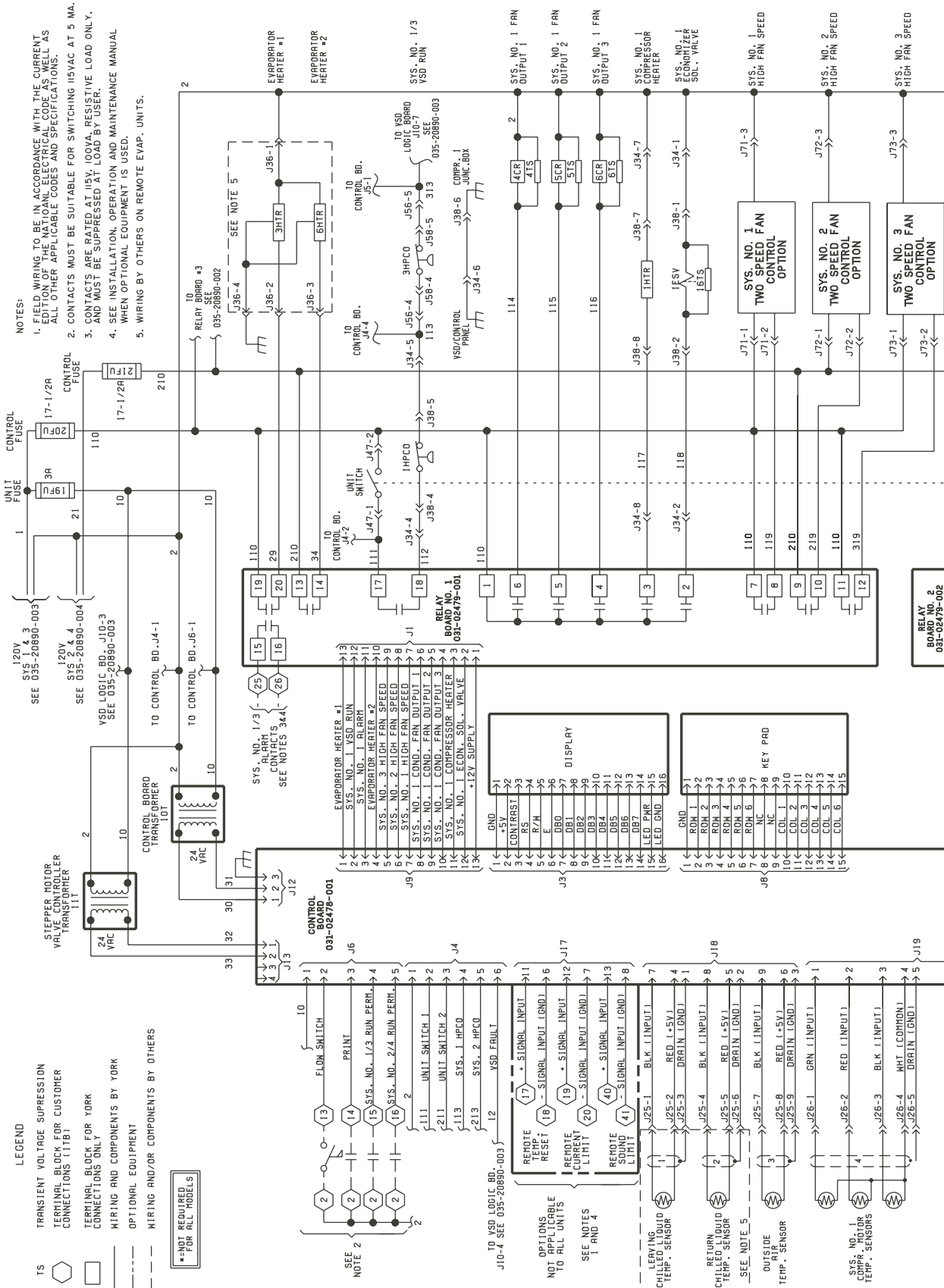



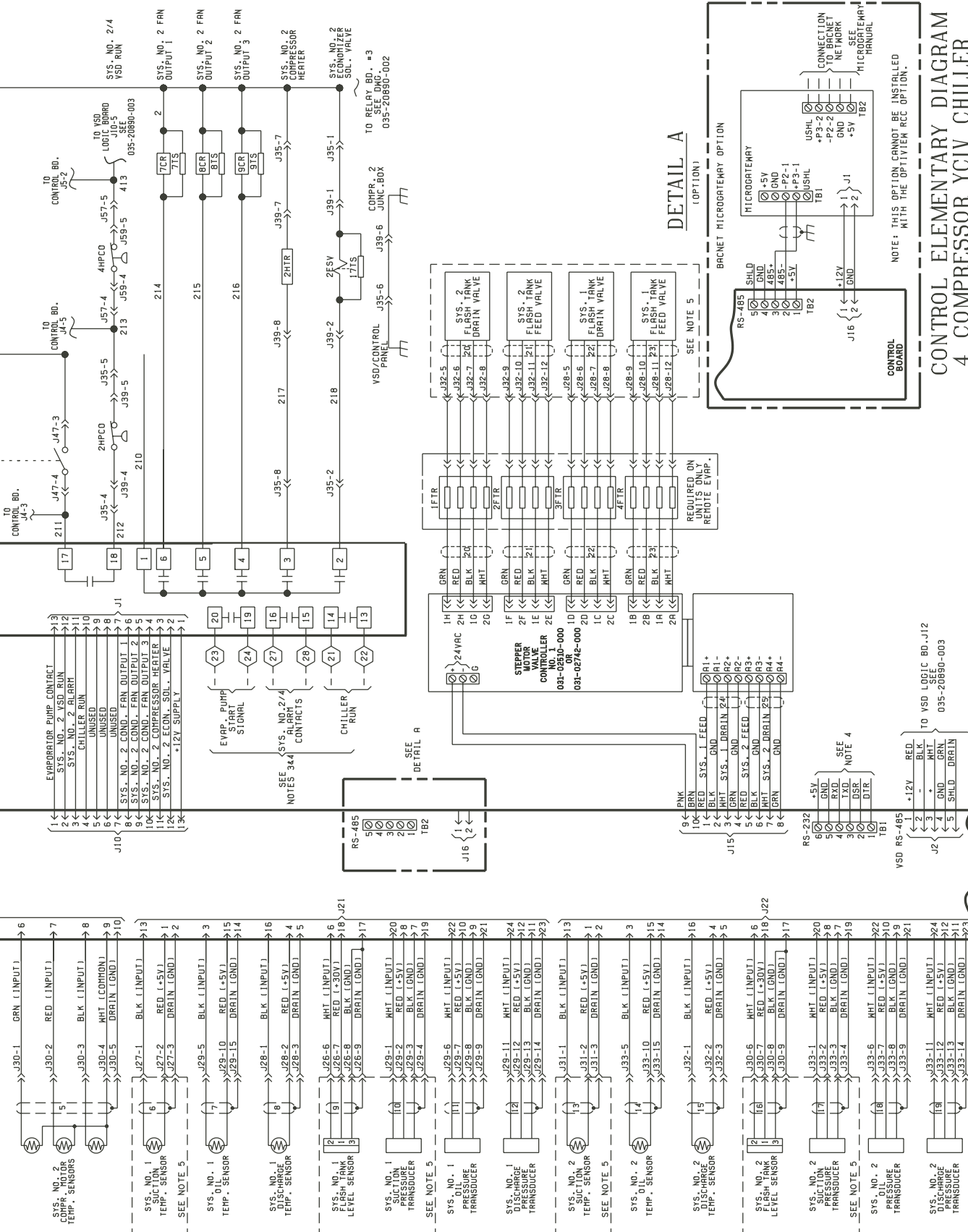

**CONTROL ELEMENTARY DIAGRAM**  
**4 COMPRESSOR YCIV CHILLER**  
**035-20890-001 REV. E**

CONTINUED TO 035-20890-002

# Application Data

## UNIT LOCATION

The YCIV chillers are designed for outdoor installation. When selecting a site for installation, be guided by the following requirements:

1. Installation sites may be either on a roof or on ground level. (See **FOUNDATION**)
2. Select a place having an adequate supply of fresh air for the condensers. Recommended clearances for all units are shown on the **DIMENSIONS** pages.
3. Avoid locations near windows or structures where normal operating sounds may be objectionable.
4. The condenser fans are propeller-type and are not recommended for use with ductwork, filters or other impediments to airflow in the condenser air stream.
5. When it is desirable to surround the unit(s), in addition to whatever optional louver package is selected, it is recommended that the screening be able to pass the required chiller CFM without exceeding 0.1" external static pressure.
6. Protection against corrosive environments is available by ordering the units with either copper fins or cured epoxy-coating on the condenser coils. Epoxy-coated coils should be utilized with any units being installed at the seashore, or where salt spray may hit the units, or where acid rain is prevalent (copper condenser coils are not recommended where they may be exposed to acid rain).
7. On installations where winter operation is intended and snow accumulations are expected, additional elevation must be provided to insure normal condenser air flow.

## FOUNDATION

The unit should be mounted on a flat and level foundation, ground or roof, capable of supporting the entire operating weight of the equipment. Please contact your nearest Johnson Controls Sales Office for shipping and operating weights.

**Roof Locations** – Adequate structural strength to safely support the entire weight of the unit and service personnel must be provided. Care must be taken not to damage the roof during installation. If the roof is “bonded”, consult building contractor or architect for special installation requirements. Roof installations should incorporate the use of spring-type isolators to minimize the transmission of vibration into building structure. Additional support should be provided to the roof at the spring-isolator locations.

**Ground Locations** – Units must be installed on a substantial base that will not settle and cause strain on the refrigerant lines, resulting in possible leaks. A one-piece concrete slab, with footers extending below the frost line, is recommended. The slab should not be tied to the main building foundation as operational noise will telegraph.

Mounting holes (5/8") are provided in the base rails for bolting the unit to its foundation. See **DIMENSIONS** for location of the mounting holes.

For ground installations, precautions should be taken to protect the unit from tampering by, or injury to, unauthorized persons. Fasteners on access panels will prevent casual tampering; however, further safety precautions, such as unit enclosure options, a fenced-in enclosure, or locking devices on the panels may be advisable. Check local authorities for safety regulations.

## CHILLED LIQUID PIPING

The chilled liquid piping system should be laid out so that the circulating pump discharges into the cooler. The inlet and outlet cooler-liquid connections are given in **DIMENSIONS**. Hand stop valves are recommended for use in all lines to facilitate servicing. Drain connections should be provided at all low points to permit complete drainage of the cooler and system piping.

The evaporator must be protected by a strainer, preferably of 40 mesh, fitted as close as possible to the liquid inlet connection, and provided with a means of local isolation.

The evaporator must not be exposed to flushing velocities or debris released during flushing. It is recommended that a suitably sized bypass and valve arrangement is installed to allow flushing of the piping system. The bypass can be used during maintenance to isolate the heat exchanger without disrupting flow to other units.

Pressure-gauge connections are recommended for installation in the inlet and outlet water lines. Gauges are not provided with the unit and are to be furnished by others.

Chilled liquid lines exposed to the weather should be wrapped with a supplemental heater cable and insulated, or glycol should be added to the chilled liquid to protect against freezing if low-ambient periods are expected.

A flow switch is available as an accessory on all units. A flow switch must be installed in the leaving water piping of the cooler and must not be used to start and stop the unit.

## PART 1 — GENERAL

### 1.01 SCOPE

- A. The requirements of the General Conditions, Supplementary Conditions, and Drawings apply to all work herein.
- B. Provide microcomputer controlled, twin-screw compressor, air-cooled, liquid chillers of the scheduled capacities as shown and indicated on the drawings, including but not limited to:
  - 1. Chiller package
  - 2. Charge of refrigerant and oil.
  - 3. Electrical power and control connections
  - 4. Chilled water connections
  - 5. Factory start-up

### 1.02 QUALITY ASSURANCE

- A. Products shall be Designed, Tested, Rated and Certified IAW, and installed in compliance with applicable sections of the following Standards and Codes:
  - 1. AHRI 550/590 – Water Chilling Packages Using the Vapor Compression Cycle
  - 2. AHRI 70 – Sound Rating of Large Outdoor Refrigerating and Air Conditioning Equipment
  - 3. ANSI/ASHRAE Standard 15 – Safety Code for Mechanical Refrigeration
  - 4. ASHRAE 34 – Number Designation and Safety Classification of Refrigerants
  - 5. ASHRAE 90.1 – Energy Standard for Buildings Except Low-Rise Residential Buildings
  - 6. ANSI/NFPA Standard 70 – National Electrical Code (N.E.C).
  - 7. ASME Boiler and Pressure Vessel Code, Section VIII, Division 1.
  - 8. ASTM A48 – Gray Iron Castings
  - 9. OSHA – Occupational Safety and Health Act
  - 10. Manufactured in facility registered to ISO 9001
  - 11. Conform to Underwriters Laboratories (U.L.) for construction of chillers and provide U.L./cU.L. listing label.
- B. Factory Test: Chiller shall be pressure-tested, evacuated and fully charged with refrigerant and oil, and shall be operationally run tested with water flowing through the vessel at the factory.
- C. Chiller manufacturer shall have a factory trained and supported service organization.

- D. Warranty: Manufacturer shall Warrant all equipment and material of its manufacture against defects in workmanship and material for a period of eighteen (18) months from date of initial start-up or date of availability.

### 1.03 DELIVERY AND HANDLING

- A. Unit shall be delivered to job site fully assembled and charged with refrigerant and oil by the Manufacturer.
- B. During shipment, provide protective covering over vulnerable components. Fit nozzles and open ends with plastic enclosures.
- C. Unit shall be stored and handled per Manufacturer's instructions.

## PART 2 — PRODUCTS

### 2.01 GENERAL

- A. Manufacturers: The design shown on the drawings is based on a Johnson Controls design. Alternate equipment will be acceptable if the equipment meets the scheduled performance and complies with Johnson Controls' specifications. If equipment manufactured by a manufacturer other than that scheduled is utilized, then the Mechanical Contractor shall be responsible for coordinating with the General Contractor and all affected Subcontractors to insure proper provisions for installation of the furnished unit. This coordination shall include, but not be limited to, the following:
  - 1. Structural supports for units.
  - 2. Piping size and connection/header locations.
  - 3. Electrical power requirements and wire/conduit and overcurrent protection sizes.
  - 4. Chiller physical size on plant layout.
  - 5. Site noise considerations.

The Mechanical Contractor shall be responsible for all costs incurred by the General Contractor, Subcontractors, and Consultants to modify the building provisions to accept the furnished units.

- B. Description: Install and commission, as shown on the schedules and plans, factory assembled, charged, and operational tested air-cooled screw compressor chiller(s) as specified herein. Chiller shall include, but is not limited to: a complete system with multiple independent refrigerant circuits, semihermetic twin screw compressors, shell and tube type evaporator, air-cooled condenser, HFC-134a refrigerant, lubrication system, interconnecting wiring, safety and operating

# Guide Specifications

controls including capacity controller, control center, motor starting components, and special features as specified herein or required for safe, automatic operation.

## C. Operating Characteristics:

1. Provide low ambient control and high ambient options as required to ensure unit is capable of operation from 0°F to 125°F (-18°C to 52°C) ambient.
2. Provide capacity control system capable of reducing unit capacity to (10% for 2 compressor units, 7.5% for 3 compressor units, and 5% for 4 compressor units) of full load. Compressor shall start in unloaded condition. Application of factory installed hot gas bypass shall be acceptable as required to meet specified minimum load.

D. Cabinet: Unit panels, structural elements, control boxes and heavy gauge structural base shall be constructed of galvanized steel. Unit panels, control boxes and structural base are finished with a baked on powder paint. All painted surfaces shall be coated with baked on powder paint which, when subject to ASTM B117, 1,000 hour, 5% salt spray test, yields minimum ASTM 1654 rating of "6".

E. Unit shall ship in one piece and shall require installer to provide only a single evaporator inlet and outlet pipe connection. If a chiller model that ships in multiple pieces is provided, bid shall include all the material and field labor costs for factory authorized personnel to install a trim kit to connect the pieces as well as all interconnecting piping and wiring.

## 2.02 COMPRESSORS AND MOTORS

A. Compressors: Shall be direct drive, semihermetic, rotary twin-screw type, including: muffler, temperature actuated 'off-cycle' heater, rain-tight terminal box, discharge shut-off service valve, and precision machined cast iron housing mounted on elastomeric isolators. Design working pressure of entire compressor, suction to discharge, shall be 350 psig (24 barg) or higher. Compressor shall be U.L. recognized.

B. Motors: Refrigerant suction-gas cooled accessible hermetic compressor motor, full suction gas flow through 0.006" maximum mesh screen, with inherent internal thermal overload protection and external current overload on all three phases.

C. Lubrication: External oil separators with no moving parts, 450 psig design working pressure, and UL listing are provided on the chiller. Refrigerant system differ-

ential pressure shall provide oil flow through service replaceable, 0.5 micron, full flow, cartridge type oil filter internal to compressor. Filter bypass, less restrictive media, or oil pump not acceptable.

D. Capacity Control: Compressors shall start at minimum load. Provide Microprocessor control to command compressor capacity to balance compressor capacity with cooling load. When required to meet minimum load, hot gas bypass shall be factory installed and integrated into standard control system.

## 2.03 REFRIGERANT CIRCUIT COMPONENTS

A. Each independent refrigerant circuit shall include: liquid line shutoff valve with charging port, low side pressure relief device, removable core filter-drier, sight glass with moisture indicator, and electronic expansion valve (EEV).

B. Chiller manufacturer shall provide independent circuit for each compressor to provide maximum redundancy during chiller operation. If equipment does not have independent circuits per compressor, manufacturer shall provide owner one spare compressor of each unique size.

C. Discharge lines shall be provided with manual compressor shutoff service valves. Suction line shall be covered with closed cell foam insulation.

## 2.04 HEAT EXCHANGERS

### A. Evaporator:

1. Direct expansion type or flooded type shell and tube evaporator with high efficiency copper tubes. Independent refrigerant circuits shall be provided per compressor.
2. Constructed, tested, and stamped IAW applicable sections of ASME pressure vessel code for minimum 235 psig (16 barg) refrigerant side design working pressure and 150 psig (10 barg) water side design working pressure.
3. Shell covered with 3/4" (19mm), flexible, closed-cell insulation, thermal conductivity of 0.26k (BTU/HR-Ft<sup>2</sup>-°F/in.) maximum. Water nozzles with grooves for mechanical couplings, and insulated by Contractor after pipe installation.
4. Provide vent and drain fittings, and thermostatically controlled heaters to protect to -20°F (-29°C) ambient in off-cycle.

### B. Air-cooled Condenser:

1. Coils: Internally enhanced, seamless copper tubes, mechanically expanded into aluminum

alloy fins with full height collars. Subcooling coil an integral part of condenser. Design working pressure shall be 450 psig (31 barg).

2. Low Sound Fans: Shall be dynamically and statically balanced, direct drive, corrosion resistant glass fiber reinforced composite blades molded into low noise, full airfoil cross section, providing vertical air discharge from extended orifices. Guards of heavy gauge, PVC (polyvinyl chloride) coated or galvanized steel.
3. Fan Motors: High efficiency, direct drive, 3-phase, insulation class "F", current protected, Totally Enclosed Air Over (TEAO), with double sealed, permanently lubricated ball bearings.

## 2.05 POWER AND ELECTRICAL REQUIREMENTS

### A. Power/Control Panel:

1. NEMA 3R (IP55), powder painted steel cabinets with hinged, latched, and gasket sealed outer doors equipped with wind struts for safer servicing. Provide main power connection(s), compressor starters and fan motor contactors, current overloads, and factory wiring.
2. Panel shall include control display access door.

### B. Single Point Power (As standard for 2 and 3 compressor chillers)

1. Provide single point power connection to chiller, shall be 3 phase of scheduled voltage.
2. Terminal Block connections shall be provided at the point of incoming single point connection.

### C. Control Transformer: Power panel shall be supplied with a factory mounted and wired control transformer that will supply all unit control voltage from the main unit power supply. Transformer shall utilize scheduled line voltage on the primary side and provide 115V/1Ø on secondary.

### D. Short Circuit Withstand Rating of the chiller electrical enclosure shall be (380, 400, & 460V: 65,000 Amps). Rating shall be IAW UL508.

### E. Motor Starters: Motors starters shall be reduced inrush type (Wye-Delta or Solid State) for minimum electrical inrush. Across the line type starters will not be acceptable.

### F. Power Factor:

1. Provide equipment with power factor correction capacitors as required to maintain a displacement power factor of 95% at all load conditions.

2. The installing contractor is responsible for additional cost to furnish and install power factor correction capacitors if they are not factory mounted and wired.

### G. Exposed compressor and fan motor power wiring shall be routed through liquid tight conduit.

## 2.06 CONTROLS

### A. General:

1. Provide automatic control of chiller operation including compressor start/stop and load/unload, anti-recycle timers, condenser fans, evaporator pump, evaporator heater, unit alarm contacts and run signal contacts.
2. Chiller shall automatically reset to normal chiller operation after power failure.
3. Unit operating software shall be stored in non-volatile memory. Field programmed set points shall be retained in lithium battery backed regulated time clock (RTC) memory for minimum 5 years.
4. Alarm contacts shall be provided to remote alert for any unit or system safety fault.

### B. Display and Keypad:

1. Provide minimum 80 character liquid crystal display that is both viewable in direct sunlight and has LED backlighting for nighttime viewing. Provide one keypad and display panel per chiller.
2. Display and keypad shall be accessible through display access door without opening main control/electrical cabinet doors.
3. Display shall provide a minimum of unit setpoints, status, electrical data, temperature data, pressures, safety lockouts and diagnostics without the use of a coded display.
4. Descriptions in English (or available language options), numeric data in English (or Metric) units.
5. Sealed keypad shall include unit On/Off switch.

### C. Programmable Setpoints (within Manufacturer limits): display language; leaving chilled liquid temperature: setpoint, control range; local or remote control; units of measure; compressor lead/lag; and maximum chilled water setpoint reset temperature range.

### D. Display Data: Chiller liquid return and leaving temperatures, ambient, lead compressor identification, clock and schedule, (variable) out of range, remote input indication, chilled liquid reset setpoint, and history

# Guide Specifications

data for last ten shutdown faults. Compressor suction, discharge, and oil pressures and temperatures, suction and discharge superheats, percent of full-load, operating hours, starts, and anti-recycle timer status. Status Messages for manual override, unit switch off, compressor run, run permissive, remote controlled shut down, no cooling load, daily/holiday shut down, anti-recycle timer.

E. Predictive Control Points: Unit controls shall avoid safety shutdown when operating outside design conditions by optimizing the chiller controls and cooling load output to stay online and avoid safety limits being reached. The system shall monitor the following parameters and maintain the maximum cooling output possible without shutdown of the equipment: motor current, suction pressure and discharge pressure.

F. System Safeties: Shall cause individual compressor systems to perform auto-reset shut down; manual reset required after the third trip in 90 minutes. Includes: high discharge pressure or temperature, low suction pressure, high / low motor current, high motor temperature, high pressure switch, high / low differential oil pressure, high oil temperature, low suction superheat, critical sensor malfunction, low or high current, phase loss/single phase power, overload of motor windings, and low voltage.

G. Unit Safeties: Shall be automatic reset and cause compressors to shut down if: high or low ambient, low leaving chilled liquid temperature, under voltage, and flow switch operation. Contractor shall provide flow switch and wiring per chiller manufacturer requirements.

H. Manufacturer shall provide any controls not listed above, necessary for automatic chiller operation. Mechanical Contractor shall provide field control wiring necessary to interface sensors to the chiller control system.

## 2.07 ACCESSORIES and OPTIONS

Some accessories and options supersede standard product features. Your Johnson Controls representative will be pleased to provide assistance.

### A. Sound Reduction

1. Provide the following options as required to meet scheduled sound performance data at all load points.
  - a. Normal speed fans and unlined compressor enclosure. (**Factory Mounted**)

- b. Two-speed fans and acoustically lined enclosure. (**Factory Mounted**)

- c. Sound power octave band data, dB per AHRI standard 70 and IAW ISO3744 at 35°C ambient and 7°C leaving chilled water.

2. Provide optional control input to limit sound output of the chiller based on time of day. Shall be programmable at the chiller panel or controlled remotely via signal (4-20mA or 0-10 VDC) from BAS system. Chillers without this feature shall be provided with the necessary sound attenuation to meet the scheduled sound performance data at all load points.

### B. Power Supply/Connections:

1. Circuit breaker is optional at point of incoming single point connection to provide disconnecting means AND be sized to provide the motor branch circuit protection, short circuit protection and ground fault protection for the motor branch-circuit conductors, the motor control apparatus and the motors. Circuit breaker shall be equipped with lockable operating handle that shall extend through power panel door so that power may be disconnected without opening any panel doors.

### C. Condenser Coil Environmental Protection:

1. **PRE-COATED FIN CONDENSER COILS –**  
The air-cooled condenser coils are constructed of epoxy-coated aluminum fins.
2. **COPPER FIN –** Provide condenser coils with copper fins in lieu of aluminum fins.
3. **POST-COATED EPOXY DIPPED CONDENSER COILS –** The unit is built with dipped-cured condenser coils.

### D. Protective Chiller Panels (**Factory Mounted**):

1. Louvered Panels (condenser coils only): Painted steel to match unit panels, over external condenser coil faces.
2. Wire Panels (full unit): Heavy gauge, welded wire mesh, coated to resist corrosion, to protect condenser coils from incidental damage and restrict unauthorized access to internal components.
3. Louvered Panels (full unit): Painted steel to match unit panels, to protect condenser coils from incidental damage, visually screen internal components, and prevent unauthorized access to internal components.
4. Louvered/Wire Panels: Louvered steel panels on external condenser coil faces, painted to match

unit panels. Heavy gauge, welded wire-mesh, coated to resist corrosion, around base of machine to restrict unauthorized access.

E. Evaporator options:

1. Provide 1-1/2" (38mm) cooler insulation in lieu of standard 3/4" (19mm).
2. Provide Raised Face Flanges for cooler nozzles:
  - a. 150 psig (10.3 barg), welded flanges (field kit, matching pipe flange by contractor).
  - b. 150 psig (10.3 barg) companion flanges. (not available with 460V units)
  - c. 150 psig (10.3 barg), ANSI/AWWA C-606 couplings (field kit, matching pipe flange by contractor).

F. Flow Switch (**Field Mounted**): Vapor proof SPDT, NEMA 3R switch [ \_\_\_ 150 psig (10.3 barg) or \_\_\_ 300 psig (20.7 barg)], -20°F to 250°F (-28.9°C to 121.1°C).

G. Building Automation System Interface:

1. Chiller to accept 4 to 20mA or 0 to 10 VDC input to reset the leaving chilled liquid temperature. (**Factory Mounted**)

H. Multi-Unit Sequence Control (**Field Mounted**): Separate Sequencing control center provided to permit control of up to eight chillers in parallel based on mixed liquid temperature.

I. Vibration Isolation (**Field Mounted**):

1. Elastomeric Isolators.
2. 1 Inch Deflection Spring Isolators: Level adjustable, spring and cage type isolators for mounting under the unit base rails.

3. 2" Deflection Seismic Isolators: Level adjustable, restrained mounts in rugged welded steel housing with vertical and horizontal limit stops. Housings shall be designed to withstand a minimum 1.0g accelerated force in all directions to 2" (50.8 mm).

J. Service Shut-Off Valve: Provide suction service shut-off valve for each compressor. (**Factory Mounted**)

## PART 3 — EXECUTION

### 3.01 INSTALLATION

- A. General: Rig and Install in full accordance with Manufacturer's requirements, Project drawings, and Contract documents.
- B. Location: Locate chiller as indicated on drawings, including cleaning and service maintenance clearance per Manufacturer instructions. Adjust and level chiller on support structure.
- C. Components: Installing Contractor shall provide and install all auxiliary devices and accessories for fully operational chiller.
- D. Electrical: Coordinate electrical requirements and connections for all power feeds with Electrical Contractor (Division 16).
- E. Controls: Coordinate all control requirements and connections with Controls Contractor.
- F. Finish: Installing Contractor shall paint damaged and abraded factory finish with touch-up paint matching factory finish.

Printed on recycled paper

Form 201.23-EG2 (713) New Release  
© 2013 Johnson Controls, Inc. P.O. Box 423, Milwaukee, WI 53201 Printed in USA  
[www.johnsoncontrols.com](http://www.johnsoncontrols.com)

